



MONASH University
Accident Research Centre

**REVIEW OF TRUCK SAFETY:
STAGE 1: FRONTAL, SIDE
AND REAR UNDERRUN PROTECTION**

Contract No RSD 2000/01 - 0069

JOHN LAMBERT

B.E (Agric). ARMIT (Mech). M.I.E.Aust.

GEORGE RECHNITZER

B.Eng.(Civil), M. Eng. M.I.E.Aust.

A RESEARCH PROJECT FOR
VICROADS

April, 2002

Report No. 194

MONASH UNIVERSITY ACCIDENT RESEARCH CENTRE
REPORT DOCUMENTATION PAGE

Report No.	Date	ISBN	Pages
194	2002	0 7326 1493 7	104

Title and sub-title:

Review of Truck Safety: Stage 1: Frontal, Side and Rear Underrun Protection

Author(s):

Lambert, J McK. & Rechnitzer, G.

Type of Report & Period Covered

General, 2001/2002

Sponsoring Organisation(s):

VicRoads

Abstract:

The aim of the project is to review and report on the issue of front, rear and side underrun crashes. In particular this was defined as to:

- Review and collate the findings from major Australian studies examining underrun crashes involving heavy vehicles, including those that were carried out for VicRoads and FORS during the 1990s.
- Carry out a literature review to identify any relevant overseas findings and developments subsequent to these studies including any existing or proposed design standards for underrun protection.
- Produce an updated report on front rear and side underrun that could be used as the basis of a submission to the Federal Government, seeking the introduction of appropriate Australian Design Rules to address the issue of underrun.

Based on the work detailed above, it is recommended that design standards be as follows.

Force application point	FRONT underrun	Rear underrun	Side underrun
outer edges	400 kN	200 kN	1 kN
centre	200	100	
intermediate	300	150	
Allowed deflection	as far as possible and up to 600 mm energy absorbing	300-400 energy absorbing	30 in front of wheels, 300 elsewhere
Height	350	350	350
Style			smooth or flat panels only

Given consideration of levels of deceleration and the road users under threat, it is recommended that the requirements apply to all heavy vehicles and possibly as low as vehicles of 3 tonne GVM.

Key Words:

Safety, accident, injury, heavy vehicle, design, vehicle occupants, under-ride protection

Disclaimer

The views expressed are those of the authors, and not necessarily those of Monash University, VicRoads, or of the aforementioned organisations or people

Reproduction of this page is authorised

Monash University Accident Research Centre,
Wellington Road, Clayton, Victoria, 3800, Australia.
Telephone: +61 3 9905 4371, Fax: +61 3 9905 4363

Contents

EXECUTIVE SUMMARY	vii
1. BACKGROUND TO PROJECT	1
2. PROJECT OBJECTIVES	1
3. HEAVY VEHICLE CRASH PROFILE	2
3.1 HEAVY VEHICLE – LIGHT VEHICLE CRASHES – NO UNDERRUN	2
3.2 HEAVY VEHICLE – LIGHT VEHICLE CRASHES – EFFECT OF UNDERRUN.....	3
3.3 HEAVY VEHICLE – PEDESTRIAN, BICYCLISTS AND MOTORCYCLISTS– EFFECT OF UNDERRUN.....	4
3.4 HEAVY VEHICLE CRASHES – SUMMARY INCLUDING CONSIDERATION OF UNDERRUN EFFECTS.....	5
4. CURRENT TRUCK AND TRAILER DESIGNS	7
4.1 FRONTAL DESIGN	7
4.2 SIDE DESIGN.....	7
4.3 REAR DESIGN	8
5. ADR REQUIREMENTS AND GROUND CLEARANCE.....	9
6. INTERNATIONAL UNDERRUN STANDARDS	10
7. UNDERRUN PROTECTION DEVICES.....	11
8. RECOMMENDATIONS	12
8.1 FRONT UNDERRUN BARRIERS.....	12
8.2 REAR UNDERRUN BARRIERS	13
8.3 SIDE UNDERRUN BARRIERS.....	13
APPENDIX A MODELLING OF TRUCK-CAR CRASHES	15
APPENDIX B: LITERATURE SEARCH.....	35
APPENDIX C: DEFLECTION OF CARS AWAY FROM THE FRONT OF TRUCKS IN OFFSET HEAD ON CRASHES	69
APPENDIX D: CURRENT TRUCK DESIGNS AND THE POTENTIAL FOR FRONT UNDERRUN	72
APPENDIX E: CURRENT TRUCK DESIGNS AND THE POTENTIAL FOR SIDE UNDERRUN	74
APPENDIX F: CURRENT TRUCK & TRAILER DESIGNS AND THE POTENTIAL FOR REAR UNDERRUN	78
APPENDIX G: UNDERRUN AND GROUND CLEARANCE ON NEW VEHICLES.....	80
APPENDIX H: HEAVY VEHICLE SAFETY STANDARDS ON UNDERRUN.....	83
REFERENCES	87

ACKNOWLEDGEMENTS

This project was funded by VicRoads. Road safety Division Mr Ross McArthur was the superintendent of the contract, and Dr Gray Scott the contract manager.

PICTURES AND IMAGES USED IN THIS REPORT

Images used in this report are for illustrative purposes. They are:

- Images taken from truck manufacturer or supplier brochures;
- Images taken from previously published reports; or
- Images obtained by the writer or George Rechnitzer through use of a digital camera.

The use of any image does not imply an endorsement of the vehicle shown, nor does it imply a criticism of that vehicle as being deficient in any aspect.

Where images are of personally owned vehicles they have been digitally altered to remove identifying marks.

In some instances the background and/or foreground has been digitally altered to improve the clarity of images as they relate to this report.

EXECUTIVE SUMMARY

This report is the outcome of a project undertaken by Monash University Accident Research Centre on behalf of VicRoads

PROJECT AIM

The aim of the project is to review and report on the issue of front, rear and side underrun crashes. In particular the aim was specified as to:

- Review and collate the findings from major Australian studies examining underrun crashes involving heavy vehicles, including those that were carried out for VicRoads and FORS during the 1990s.
- Carry out a literature review to identify any relevant overseas findings and developments subsequent to these studies including any existing or proposed design standards for underrun protection.
- Produce an updated report on front rear and side underrun that could be used as the basis of a submission to the Federal Government, seeking the introduction of appropriate Australian Design Rules to address the issue of underrun.

METHOD

The method used was to review recent papers on underrun protection as well as initiatives undertaken by manufacturers and operators of heavy vehicles, and combine that with the knowledge and experience of the writers to produce the final report

MAJOR AUSTRALIAN STUDIES

The major Australian studies in the last decade related to underrun have been:

- Truck Involved Crash Study – Interim report on fatal and injury crashes of cars into the rear of trucks – George Rechnitzer and Foong Chee Wai, May 1991.
- Truck Involved Crash Study – Interim report on fatal and injury crashes of cars and other road users with the front and sides of heavy vehicles – George Rechnitzer, February 1993
- Heavy Vehicle Crashes in Urban Areas - Sweatman, Ogden, Haworth Corben, Rechnitzer and Diamantopoulou, November 1995
- Development and Testing of Energy Absorbing Rear Underrun Barriers for Heavy Vehicles - Rechnitzer, Powell and Seyers, May 1996
- Design Principles for Underride guards and Crash Test results - Rechnitzer, April 1997
- Energy Absorbing Rear Underrun Barriers for Heavy vehicles - Rechnitzer, June 2000

MAJOR OVERSEAS STUDIES

The major OVERSEAS studies in the last decade were either presented or referenced at the SAE Heavy Vehicle Underride Protection TOPTEC conference held on April 15-16 1997 at Palm Springs. Included were:

- Federal Motor Vehicle Safety Standards Requirements for Rear Underride Protection. George E Mouchahoir, Safety Engineer, US Department of Transportation, NHTSA
- Underride Guards: Is the New NHTSA Regulation Good Enough? Byron Bloch, Consultant, Auto Safety Design
- Truck Underride Studies - Cornell 1970: IIHS –1977 and Dynamic Science, 1980
- Comparison of Incidence of Large Truck – Passenger Vehicle Underride crashes in the Fatal Accident Reporting System and the National Accident Sampling System and a Photograph-based Study. Elisa R Braver from Insurance Institute for Highway Safety
- Heavy truck Underride risk analysis. Edmund Lau, Managing Scientist, Failure Analysis Associates
- Underride collisions – A Canadian Perspective. E R Welbourne and D Boucher, Transport Canada
- EEVC Working Group 14 Activities in Energy-Absorbing Front Underrun Protection. Peter J A de Co, Scientific Research Associate, TNO) Road-Vehicles Research Institute, Crash Safety research Centre
- Heavy Vehicle Frontal Aggressiveness: Crash Test Results with Countermeasure Concepts. Alope K Prasad, supervisor, research Scientist, Transportation Research Center, Vehicle research and Test Center, US Department of Transportation

OVERSEAS REGULATIONS

These include:

ECE Regulation No 58 – Rear Underrun Protection

USA Federal Motor Vehicle Safety Standard 223 – Rear Impact Guards (test requirements) and Federal Motor Vehicle Safety Standard 224

ECE Regulation No 73 – Lateral Protection of Trailers and Semi-trailer goods vehicles

ECE Regulation No 93 – Front Underrun Protective devices

MODELLING HEAVY VEHICLE CRASHES

Modelling of heavy vehicle crashes gave the average decelerations listed below

	Light vehicle	3 tonne HV	5 tonne HV	10 tonne HV	20 tonne or more
70 km/h start for light vehicle and heavy vehicle for head on and sideswipe. Heavy has zero speed in direction of travel of light vehicle for other crashes					
Full side	2 g	2 g	3 g	4.5 g	6 or more
Full rear	2 g	3 g	4 g	5 g	7 or more
Side swipe	5 g	12 g	15 g	17 g	18 or more
Full head on	10 g	22.5 g	30 g	33 g	35 or more
Full truck into side of car	6 g	8 g	9 g	10 g	11 or more
100 km/h start for light vehicle and heavy vehicle for head on and sideswipe. Heavy has zero speed in direction of travel of light vehicle for other crashes					
Full side	3 g	5 g	7 g	8 g	12 or more
Full rear	3 g	5 g	7 g	9 g	12 or more
Side swipe	8 g	20 g	23 g	26 g	28 or more
Full head on	14 g	32 g	38 g	43 g	46 or more
Full truck into side of car	12 g	15 g	17 g	19 g	20 or more

The much greater severity of head on crashes is clearly evident. For head on crashes a heavy vehicle weight of only 3 tonnes or twice that of the light vehicle results in high and possibly life threatening decelerations, even in urban arterial road environments.

As the figures show average deceleration, peak decelerations will be two or more times higher based on other research. Averages of around 20 g or greater would be considered likely to result in fatal outcomes.

HEAVY VEHICLE – LIGHT VEHICLE CRASHES – EFFECT OF UNDERRUN

Underrun has two major effects on the outcome of crashes:

- underrun can expose light vehicle occupants to direct contact with rigid structural parts of the vehicle before the light vehicle's crashworthiness has fully come into play; and
- components of the heavy vehicle (steer axle, other axles, braking components et cetera) can be compromised to the degree that the vehicle is not controllable in coming to a stop, or the vehicle cannot be moved after the collision

Of particular concern are:

Side underrun and side swipe where the angle of approach exposes the occupants to cabin intrusion from the tray or body of the heavy vehicle,

Rear underrun where the amount of underrun before contact with the rear axle is large;

Offset rear underrun where the bonnet of the light vehicle can pass under the tray so that the tray or body of the truck acts as a “blunt” guillotine. Note that the existence of current approved underrun design may do little to provide protection in these.

Full head on underrun where any amount of underrun may significantly compromise crashworthiness.

Offset front underrun in head on crashes where the light vehicle is likely to collide with the steer axle and compromise the heavy vehicles steering.

Front underrun in truck into car crashes where the underrun may lead to the heavy vehicle running over the light vehicle or in rear end collisions push the petrol tank down and causing it to rupture

HEAVY VEHICLE – PEDESTRIAN, BICYCLISTS AND MOTORCYCLISTS– EFFECT OF UNDERRUN

Underrun with heavy vehicle front or sides allows unprotected road users to be trapped underneath the vehicle or run over by the wheels.

HEAVY VEHICLE CRASHES – SUMMARY INCLUDING CONSIDERATION OF UNDERRUN EFFECTS

The order of severity of decelerations in crash situations is:

- Worst case – head on crashes;
- Then truck into the side of a car;
- Then side swipe crashes – vehicles travelling in opposing directions;
- Then other rear and side crashes.

Underrun can dramatically alter the outcome of such crashes. Of particular concern are:

- Excessive rear underrun
- Excessive rear underrun and/or poor rear underrun barrier design in offset rear crashes;
- Side underrun in side swipe crashes
- Excessive front underrun and/or poor front underrun barrier design in offset front crashes

In these considerations the term "excessive" means a degree of underrun that would significantly increase the chances of intrusion of parts of the heavy vehicle into the passenger space. For front or rear underrun this would be underrun in excess of say 200-400 mm.

In summary, as noted by Rechnitzer (1993), the importance of crash involvement of different parts of the truck are:

crashes with other vehicles

- front of the truck: 66% of fatal; 68% of serious injury crashes
- side of the truck: 13% of fatal 10% of serious injury crashes.
- rear of the truck: 9% of fatal; 17% of serious injury crashes

crashes with unprotected road users:

- front of the truck 42% of fatal crashes
- side of the truck 40% of fatal crashes
- rear of the truck 12% of fatal crashes

It is clear that the design of the front of the truck to reduce the severity of impact to cars and other road users is the most important, but that for unprotected road users the design of the side of the truck is also important.

CURRENT TRUCK AND TRAILER DESIGNS

Some manufacturers like Scania have redesigned the front of heavy vehicles to ensure full engagement of the front bumper with the bumpers of light vehicles. Others like Mercedes Benz provide side underrun on rigid trucks as standard while trailer manufacturer Vawdrey has side underrun available on semi-trailers.

While most rigid trucks and prime movers have reasonably low front underrun clearances, there is a range of medium to heavy rigid trucks which have excessive front underrun clearances of 700 mm or more. Given the manufacturers of these vehicles produce larger and smaller vehicles which are better from this aspect it would seem there is no intrinsic reason why these could not be improved.

The current Australian standard for rear underrun barriers has been based on arguments that full width barriers cannot be accommodated due to the likelihood of them catching on posts while turning et cetera, and that they cannot be lower due to rear road clearance problems. However observation of the existing fleet shows many full width and low underrun structures on rigid trucks with considerable rear overhang. In addition there are many semi-trailers with rear underrun barriers that do not conform suggesting that enforcement of this requirement is lacking.

Analysis of rear overhang requirements versus mass limits on axles has found that many standard cab-chassis vehicles are being supplied with chassis that are “excessively long.” For these a uniform payload will result in the rear axle or axles being overloaded. Demand for these vehicles is driven by a desire for large volume capacity vehicles with tight turning circles. Hence the market is requiring the supply of a productive vehicle without due regard to the safety negatives associated with long rear overhang and hence high rear underrun potential.

ADR requirements and ground clearance

This is discussed in detail in Appendix G. ADR 43/04 requires that ground clearance be maintained between axles as defined by intersecting lines sloped upwards at 3.81 degrees (1:15 slope). This requirement would allow a rear underrun clearance of 250 mm at 3700 mm.

International underrun standards

All standards except side underrun refer to forces applied to three positions as shown in concept below. The actual locations of the points of application of the three forces may differ to some degree across the standards.

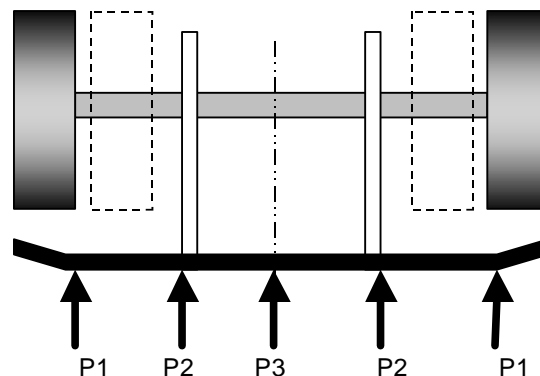

PLAN VIEW

Key features are summarised in the Table below.

Test Load (kN)	USA FMVSS 223/224 Rear	ECE R93: - FRONT*	E.C.E R58 : Rear barrier **	E.C.E R73 Side
outer edge P1	50 kN	80 kN	25 kN	1 kN
centre P3	50 kN	80 kN	25 kN	
off centre P2	100 kN	160 kN	100 kN	
Allowed deflection	125 mm	400 mm		30 mm in front of wheels, 300 mm elsewhere
Height	560 mm	400 mm	550 mm	550 mm

RECOMMENDATIONS

Based on the work detailed in the literature search, and other considerations the following recommendations are made:

Front underrun barriers

Loads and decelerations in head on crashes are much more severe than for other crashes so that the performance of these barriers must be at a significantly higher standard. Realistically the standards should be at least twice those for rear underrun barriers.

Based on modelling, the requirements for barriers should extend down to vehicles of 3.0 tonnes GVM. As average decelerations generated at a heavy vehicle GVM of 6 tonnes are 80% of those at 68 tonnes GVM, full strength should apply at this GVM at least. As smaller trucks have lower chassis heights and hence are subject to less of a cantilever

requirement in respect of a low barrier height, the one standard for the truck barrier should apply to all GVM's.

A front underrun barrier should have the following characteristics:

Rigid barrier design

- a road clearance of not more than 350mm
- full width out to the outer edge of the tyres or mudguards
- a frontal projection of at least 300mm to provide a buffer space in impacts with the sides of cars, and hence reduce the opportunity for direct head and body contact.
- curved at the ends to reduce concentrated loads being applied in angled collisions.
- A layer of progressive crush material applied to the hard surfaces that starts off “soft” for impacts with unprotected road users and the side of cars.
- static strength as set out below:

Force at P1 (kN)	Force at P2 (kN)	Force at P3 (kN)
400	300	200

Energy absorbing barrier

- a stroke equal to the maximum possible without leading to impacts on the steering wheels or axle and preferably 500 to 600mm.
- a road clearance of not more than 350mm
- full width out to the outer edge of the tyres or mudguards
- an energy absorption capacity of 100kJ.
- a frontal projection of at least 300mm to provide a buffer space in impacts with the sides of cars, and hence reduce the opportunity for direct head and body contact.
- curved at the ends to reduce concentrated loads being applied in angled collisions.
- A layer of progressive crush material applied to hard surfaces
- progressive crush of the energy absorbing barrier which starts off “soft” for impacts with unprotected road users and the side of cars, and increases progressively to suit frontal impacts with a range of cars.
- residual strength after full energy absorption, as set out below:

Force at P1 (kN)	Force at P2 (kN)	Force at P3 (kN)
400	300	200

Rear underrun barriers

Work by Rechnitzer and others with rigid and energy absorbing rear underrun barriers, plus other observations suggests the following requirements:

Rigid barrier design

- a road clearance of preferably 350 mm and not more than 400 mm
- minimal distance from the rear of the vehicle to the barrier and preferably no more than 300 mm

- full width out to the outer edge of the tyres or truck body (note that this will be a problem for trucks with bodies that significantly extend beyond the outer sides of the tyres)
- static strength as set out below:

Force at P1 (kN)	Force at P2 (kN)	Force at P3 (kN)
200	150	100

Energy absorbing barrier

- a stroke of at least 300 mm and preferably more.
- minimal distance from the rear of the vehicle to the barrier and preferably no more than 300 mm
- full width out to the outer edge of the tyres or truck body (note that this will be a problem for trucks with bodies that significantly extend beyond the outer sides of the tyres)
- an energy absorption capacity of 50kJ.
- residual strength after full energy absorption, as set out below:

Force at P1 (kN)	Force at P2 (kN)	Force at P3 (kN)
200	150	100

Side underrun barriers

Research and usage suggests that the strength of the ECE design barriers is satisfactory. However there are other aspects that need improvement.

In particular a clearance under the barrier of 550 mm is much too high to ensure unprotected road users are not run over by the wheels of the heavy vehicle.

Preferably side underrun should not be rails as there is the potential for roadusers to be caught up in the rails. Tack boxes and other items installed or carried under the tray level should form part of the barrier.

Hence it is recommended the ECE standard be adopted with the changes below:

Allowed style	smooth panels or surfaces only
Underrun clearance	350 mm

1. BACKGROUND TO PROJECT

Consideration of underrun protection has been around since the very earliest cars. The picture below is of an early bus and shows a comprehensive side underrun protection, presumably because of the real risk of passengers falling under the wheels.

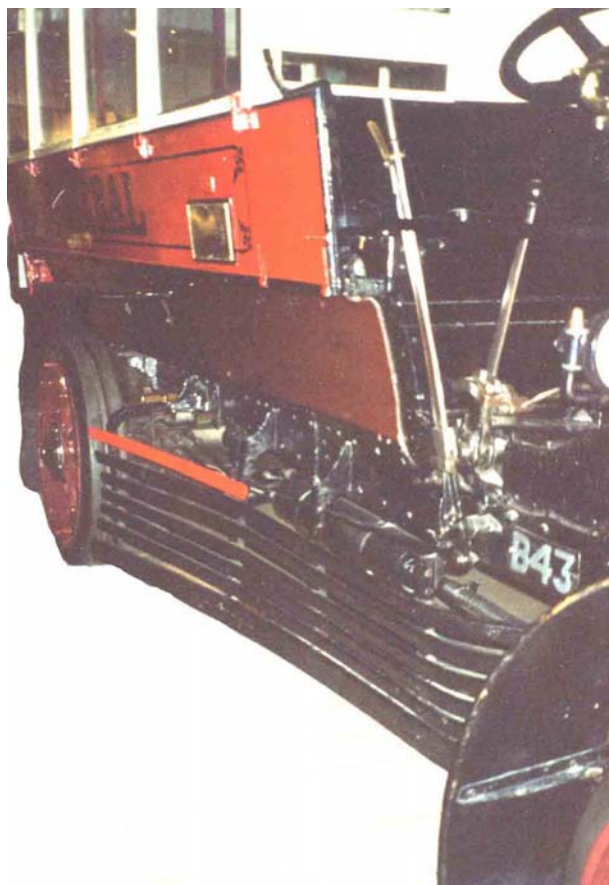

Current buses have comprehensive underrun protection to prevent such occurrences.

2. PROJECT OBJECTIVES

This project was commissioned by VicRoads with the following aims and objectives:

To review and report on the issue of front, rear and side underrun crashes. In particular the objectives were to:

- (i) Review and collate the findings from major Australian studies examining underrun crashes involving heavy vehicles, including those that were carried out for VicRoads and FORS during the 1990s.
- (ii) Carry out a literature review to identify any relevant overseas findings and developments subsequent to these studies including any existing or proposed design standards for underrun protection.
- (iii) Produce an updated report on front rear and side underrun that could be used as the basis of a submission to the Federal Government, seeking the introduction of appropriate Australian Design Rules to address the issue of underrun.

3. HEAVY VEHICLE CRASH PROFILE

The heavy vehicle crash profile is thoroughly researched by Rechnitzer (1993).

It must however be recognised that this is the outcome record – a record of the results of crash incidents. It does not reflect the relative occurrence of crash incidents. In the following sections of this report factors effecting the likely outcome of crashes are considered.

3.1 HEAVY VEHICLE – LIGHT VEHICLE CRASHES – NO UNDERRUN

The basic physics of these crashes is the billiard ball analogy except that allowance must be made for braking and energy absorption in the crumpling of the vehicles.

The range of these crashes is reviewed in Appendix A and estimated relative average decelerations are shown in the table below:

	Light vehicle	3 tonne HV	5 tonne HV	10 tonne HV	20 tonne or more
70 km/h start for light vehicle and heavy vehicle for head on and sideswipe. The heavy vehicle is assumed to have has zero speed in direction of travel of light vehicle for other crashes					
Full side	2 g	2 g	3 g	4.5 g	6 or more
Full rear	2 g	3 g	4 g	5 g	7 or more
Side swipe	5 g	12 g	15 g	17 g	18 or more
Full head on	10 g	22.5 g	30 g	33 g	35 or more
Full truck into side of car	6 g	8 g	9 g	10 g	11 or more
100 km/h start for light vehicle and heavy vehicle for head on and sideswipe. The heavy vehicle is assumed to have has zero speed in direction of travel of light vehicle for other crashes					
Full side	3 g	5 g	7 g	8 g	12 or more
Full rear	3 g	5 g	7 g	9 g	12 or more
Side swipe	8 g	20 g	23 g	26 g	28 or more
Full head on	14 g	32 g	38 g	43 g	46 or more
Full truck into side of car	12 g	15 g	17 g	19 g	20 or more

The much greater severity of head on crashes is clearly evident. The severity of side swipe crashes is also evident. Principally this is due to the heavy vehicle momentum.

It is evident that for head on crashes a heavy vehicle weight of only 3 tonnes or twice that of the light vehicle results in high and possibly life threatening decelerations, even in urban arterial road environments.

As the figures show average deceleration, peak decelerations will be two or more times higher based on other research. Averages of around 20 g or greater would be considered likely to result in fatal outcomes.

3.2 HEAVY VEHICLE – LIGHT VEHICLE CRASHES – EFFECT OF UNDERRUN

Underrun has two major effects on the outcome of crashes:

- firstly underrun can expose light vehicle occupants to direct contact with rigid structural parts of the vehicle before the light vehicles crashworthiness has fully come into play; and
- secondly components of the heavy vehicle (steer axle, other axles, braking components et cetera) can be compromised to the degree that the vehicle is not controllable in coming to a stop, or the vehicle cannot be moved after the collision

The first has a direct impact on the trauma outcomes of the collision while the second can either lead to other collisions (uncontrollable vehicle hitting fixed objects or other vehicles) or rollovers, or present a hazard to other road users by obstructing traffic.

Of particular concern are:

Side underrun and side swipe where the angle of approach exposes the occupants to cabin intrusion from the tray or body of the heavy vehicle,

Rear underrun where the amount of underrun before contact with the rear axle is large so that cabin intrusion occurs well before full crashworthiness provisions have taken effect,

Offset rear underrun where the bonnet of the light vehicle can pass under the tray so that the tray or body of the truck acts as a “blunt” guillotine. Note that the existence of compliant ADR 42/03 underrun design may do little to provide protection in these situations as the cantilevered bar provides little engagement of the light car structure. ADR 42/03 requires

9 REAR BUMPER FOR SEMI-TRAILERS

9.1 Every ‘*Semi-trailer*’ must be provided with a continuous rear bumper which must be so constructed and located that:

9.1.1 with the vehicle unladen, the lower edge of the bumper bar across its width must not be more than 600 mm from the ground;

9.1.2 the bumper contact surface is located not more than 600 mm forward of the rear of the vehicle and is painted white;

9.1.3 the ends of the bumper extend to within 300 mm of each side of the vehicle, unless the rearmost point of the tyres is within 600 mm of the ‘*Rear End*’ of the vehicle, in which case the tyres must be considered as meeting the requirements over their width;

9.1.4 the member which is, or directly supports, the bumper contact surface is of material having no less strength than steel tubing of 100 mm outside diameter and 8 mm wall thickness; and

9.1.5 the structure supporting the member referred to in clause 9.1.4 can transmit no less force than that member can sustain, and provides a continuous force path to vehicle members of a strength consistent with the forces to be sustained.

9.2 Clause 9.1 does not apply to '*Semi-trailers*' so constructed that:

9.2.1 cargo access doors, tailgates or other such structures when closed afford comparable protection; and

9.2.2 a vertical plane tangential to the rearmost surface of the rear tyres is 155 mm or less from a parallel vertical plane containing the '*Rear End*' of the '*Semi-trailer*'.

Having a ground clearance of up to 600 mm, a rear underrun to the contact surface of 600 mm, and being up to 300 mm short of the side of the vehicle allows a vehicle to pass under the corner of a heavy vehicle with little or no impedance from the rear underrun barrier.

Full head on underrun where the amount of underrun may significantly compromise crashworthiness provisions. Note that because of the severity of these crashes even relatively small degrees of underrun can be significant.

Offset front underrun in head on crashes where the light vehicle is likely to collide with the steer axle and compromise the heavy vehicles steering, and/or the underrun leads to heavy intrusion of the cabin space by the heavy vehicle structure.

Front underrun in truck into car crashes where the underrun can:

- rotate the light vehicle downwards and lead to the heavy vehicle running over the light vehicle with catastrophic results;
- push the petrol tank down and lead to fire when the truck impacts the rear of the light vehicle

3.3 HEAVY VEHICLE – PEDESTRIAN, BICYCLISTS AND MOTORCYCLISTS– EFFECT OF UNDERRUN

Underrun with heavy vehicle front or sides allows unprotected road users to be trapped underneath the vehicle or run over by the wheels.

However in regard to front underrun even prevention of underrun is unlikely to significantly improve the safety situation unless hard surfaces are covered by soft finishes.

For side underrun, prevention of unprotected road users going under the wheels is a significant method of reducing road trauma.

3.4 HEAVY VEHICLE CRASHES – SUMMARY INCLUDING CONSIDERATION OF UNDERRUN EFFECTS

As noted, order of severity of decelerations in crash situations is:

- Worst case – head on crashes;
- Then truck into the side of a car;
- Then side swipe crashes – vehicles travelling in opposing directions;
- Then other rear and side crashes.

Underrun can dramatically alter the outcome of such crashes. Of particular concern are:

- Excessive rear underrun
- Excessive rear underrun and/or poor rear underrun barrier design in offset rear crashes;
- Side underrun in side swipe crashes
- Excessive front underrun and/or poor front underrun barrier design in offset front crashes

The outcome of these effects is reflected in the results derived below from a NHTSA study (Prasad et al 1996). The table shows the ratio of fatalities to serious injury outcomes for crashes involving the front of trucks.

The overall ratio was 3.6 serious injuries per fatality.

<i>VEHICLE</i>		<i>HEAVY TRUCK</i>				
		<i>CLOCK ANGLE</i>	<i>11</i>	<i>12</i>	<i>1</i>	<i>Total</i>
<i>LIGHT VEHICLE</i>		Unknown	3.0	21.0	4.0	9.3
		1 Front	4.0	5.0		4.5
		2 Side	7.0	6.0		6.5
		3 Side		1.9		2.0
		4 Side		0.0		0.0
		5 Rear				
		6 Rear		40.0		41.0
		7 Rear				
		8 Side		4.0		5.0
		9 Side	0.0	3.5	1.0	2.5
		10 Side		1.5	2.3	2.0
		11 Front		1.0	0.7	0.9
	12 Front		1.0	1.3	1.5	
<u>OVERALL RATIOS</u>			3.6	3.9	2.6	3.6

Head on crashes show ratios of around one serious injury per fatality where vehicle are travelling in opposing directions – in USA this would be both vehicles travelling in the 11 o'clock or 12 o'clock direction.

Trucks “t-boning” the side of a car also show low ratios of 1.0 – 2.0

In contrast heavy vehicle into the rear of a light vehicle had a ratio of 40:1.

In summary, as noted by Rechnitzer, the importance of crash involvement of different parts of the truck are:

crashes with other vehicles

- front of the truck: 66% of fatal; 68% of serious injury crashes
- side of the truck: 13% of fatal 10% of serious injury crashes.
- rear of the truck: 9% of fatal; 17% of serious injury crashes

crashes with unprotected road users:

- front of the truck 42% of fatal crashes
- side of the truck 40% of fatal crashes
- rear of the truck 12% of fatal crashes

It is clear that the design of the front of the truck to reduce the severity of impact to cars and other road users is the most important, but that for unprotected road users the design of the side of the truck is also important.

4. CURRENT TRUCK AND TRAILER DESIGNS

These are referenced in detail in Appendices D, E and F.

4.1 FRONTAL DESIGN

As noted some manufacturers like Scania have redesigned the front of heavy vehicles to ensure full engagement of the front bumper with the bumpers of light vehicles. Other vehicles have front bumpers with clearances of around 400 mm or less.

However there is a range of medium to heavy rigid trucks which have excessive front underrun. These are similar in style to that shown below.



Manufacturers have advised that this arrangement arises through:

- the need to fit large radiators for Australian conditions, which in turn requires the cabin to be raised, and
- the need to fit large 11R22.5 size tyres or metric equivalents to give a tyre capacity at 100 km/h of 3000 kg per tyre (6000 kg on the front axle) at the 825 kPa tyre pressure limit that applies in Australia. This requires the chassis to be raised.

Clearances are of the order of 700 mm or more and there is typically only a light structure below that height designed to support the steps on both sides.

Given that in a number of cases the manufacturer sells smaller and larger vehicles with bumpers at much lower heights there is a need to question why these vehicles could not also be more compliant. Note that the fitting of bull bars to these vehicles does not typically improve the situation greatly as often they appear to only extend 100-150 mm lower than the supplied bumper bar level.

4.2 SIDE DESIGN

Some manufacturers of trucks and trailers have commenced supplying side underrun to the Australian market – e.g. Mercedes Benz and Vawdrey. And many prime movers have a continuous line of wheels plus fuel tanks so that there is little side underrun possible.

However there are many vehicles, especially long wheelbase and/or long rear overhang rigid trucks and semi-trailers, which have significant areas for side underrun.

4.3 REAR DESIGN

As noted in the Appendix the current standard for rear underrun barriers has been based on arguments that full width barriers cannot be accommodated due to the likelihood of them catching on posts while turning et cetera, and that they cannot be lower due to rear road clearance problems. However observation of the existing fleet shows many full width and low underrun structures on rigid trucks with considerable rear overhang. This raises legitimate questions about the previous claims.

In addition there are many semi-trailers with rear underrun barriers that do not conform with the current standard suggesting that enforcement of this requirement is lacking.

An analysis of rear overhang requirements versus mass limits on axles for standard cab-chassis vehicles supplied to the Australian market gave the results below:

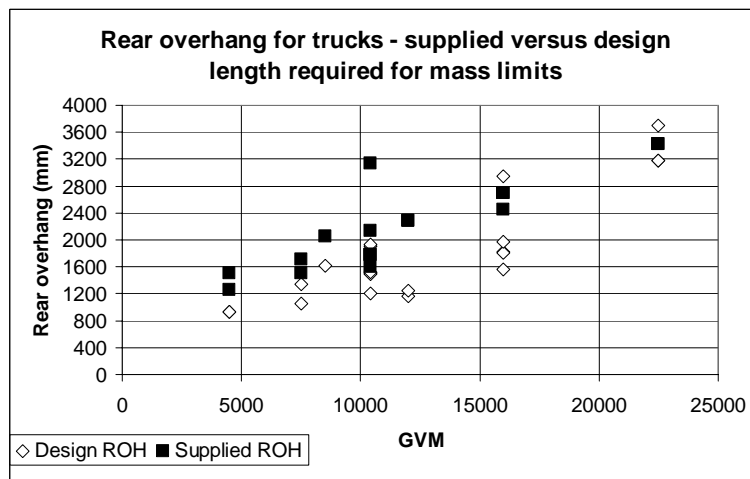

As can be seen many cab chassis vehicles are being supplied with rear overhangs that are “excessively long.” The supplied rear overhang is longer than required for the situation where a uniform maximum payload load will result in the rear axle or axles being at the legal limit. Hence in this situation the rear axle will be overloaded.

Discussions with suppliers confirms that the demand for these vehicles is driven by a desire for large volume capacity vehicles with tight turning circles. Hence arguably the market is requiring the supply of a productive vehicle without due regard to the safety negatives associated with long rear overhang and high rear underrun potential, and the pavement negatives associated with overloaded rear axles.

5. ADR REQUIREMENTS AND GROUND CLEARANCE

This is discussed in detail in Appendix G. ADR 43/04 requires that ground clearance be maintained between axles as shown in the diagram below.

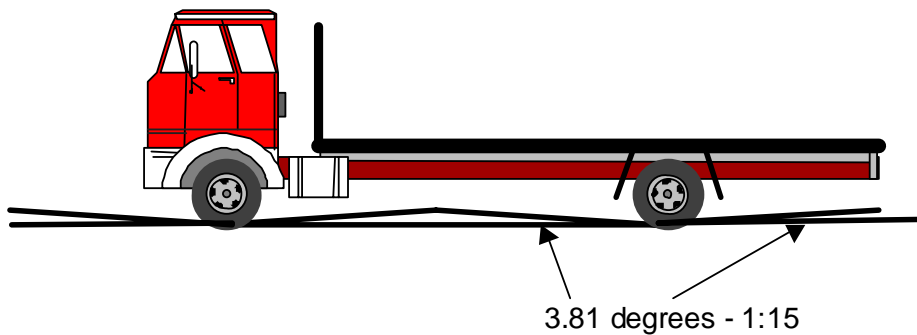

This requirement would allow rear underrun clearances of 250 mm at 3700 mm rear overhand for a rigid truck with a single rear axle, and lower clearances for rear tandem and tri-axle group trucks and trailers.

Given car carriers like that shown below operate on Australian roads it seems unlikely that there are in fact significant issues with having lower rear underrun clearances.



6. INTERNATIONAL UNDERRUN STANDARDS

These are detailed in Appendix H.

Key features are summarised in the Table below.

Test Load (kN)	USA FMVSS 223/224 Rear	ECE R93: - FRONT*	E.C.E R58 : Rear barrier **	E.C.E R73 Side
outer edge P1	50 kN	80 kN	25 kN	1 kN
centre P3	50 kN	80 kN	25 kN	
off centre P2	100 kN	160 kN	100 kN	
Allowed deflection	125 mm	400 mm		30 mm in front of wheels, 300 mm elsewhere
Height	560 mm	400 mm	550 mm	550 kN

Notes: * *These test loads apply to vehicles with a GVM >16t, for other vehicles lower values are permitted and are a function of vehicle GVM.*

** *These test loads apply to vehicles with a GVM >20t, for other vehicles lower values are permitted and are a function of vehicle GVM.*

7. UNDERRUN PROTECTION DEVICES

Devices proposed in the literature searches include:

- rigid (or near rigid) barriers – some deflection is allowed;
- energy absorbing barriers, and
- devices to deflect cars in offset collisions.

The first two have been well researched, with the advantages of an energy absorbing underrun barrier being proven though at an increase in design cost and capital cost, and possibly increased maintenance costs (replacing energy absorbing parts).

However the devices for deflecting vehicles have not been given the same degree of analysis. In Appendix C a theoretical analysis is undertaken in respect of offset frontal collisions. That analysis shows that for an expected friction factor of around 0.4, and assuming an overlap of 40% or around 720 mm, for common closing speeds of 30 km/h to 80 km/h angles of up to 60 degrees are required. However this would require front overhangs considerable larger than those that currently exist.

As a rough approximation a truck with a tapered front to these specifications would result in an increased deformation of around 100 mm to the centre of the light vehicle in a full frontal head on.

The analysis further showed that accelerations required at the larger overlaps are considerable. At 80 km/h accelerations of 10-12 g are required to deflect the vehicle at a 40% overlap. These are combined with forward decelerations of 18 – 27 g in the forward direction.

A further consideration is that the deflected vehicle will have had its steering compromised and the driver is unlikely to be in a position to control the vehicle for this reason and the effects of the forces applied to them. Hence there would be considerable potential for further collisions.

Based on the above it is considered that side deflection mechanisms are unlikely to have an impact on reducing trauma in head on light vehicle to heavy vehicle crashes.

Hence this proposal is not supported as a potential trauma reducing initiative and only rigid and energy absorbing barriers are considered in the recommendations.

8. RECOMMENDATIONS

Based on the work detailed in the literature search (Appendix B), and the other considerations included in the other appendices the following recommendations are made:

8.1 FRONT UNDERRUN BARRIERS

Loads and decelerations in head on crashes are much more severe than for other crashes so that the performance of these barriers must be at a significantly higher standard. Realistically the standards should be at least twice those for rear underrun barriers.

Based on modelling the requirements for barriers should extend down to vehicles of 3 tonnes GVM. As average decelerations generated at a heavy vehicle GVM of 6 tonnes are 80% of those at 68 tonnes GVM, full strength should apply at this GVM at least. As smaller trucks have lower chassis heights and hence less cantilever requirements in respect of a low barrier height, one standard should apply to all GVM's.

A front underrun barrier should have the following characteristics:

Rigid barrier design

- a road clearance of not more than 350mm
- full width out to the outer edge of the tyres or mudguards
- a frontal projection of at least 300mm to provide a buffer space in impacts with the sides of cars, and hence reduce the opportunity for direct head and body contact.
- curved at the ends to reduce concentrated loads being applied in angled collisions.
- A layer of progressive crush material applied to the hard surfaces that starts off “soft” for impacts with unprotected road users and the side of cars.
- static strength as set out below:

Force at P1 (kN)	Force at P2 (kN)	Force at P3 (kN)
400	300	200

Energy absorbing barrier

- a stroke equal to the maximum possible without leading to impacts on the steering wheels or axle and preferably 500 to 600mm.
- a road clearance of not more than 350mm
- full width out to the outer edge of the tyres or mudguards
- an energy absorption capacity of 100kJ.
- a frontal projection of at least 300mm to provide a buffer space in impacts with the sides of cars, and hence reduce the opportunity for direct head and body contact.
- curved at the ends to reduce concentrated loads being applied in angled collisions.
- A layer of progressive crush material applied to hard surfaces
- progressive crush which starts off “soft” for impacts with unprotected road users and the side of cars, and increases progressively to suit frontal impacts with a range of cars.

- residual strength after full energy absorption, as set out below:

Force at P1 (kN)	Force at P2 (kN)	Force at P3 (kN)
400	300	200

8.2 REAR UNDERRUN BARRIERS

Work by Rechnitzer and others with rigid and energy absorbing rear underrun barriers, plus other observations suggests the following requirements:

Rigid barrier design

- a road clearance of preferably 350 mm and not more than 400 mm
- minimal distance from the rear of the vehicle to the barrier and preferably no more than 300 mm
- full width out to the outer edge of the tyres or truck body (note that this will be a problem for trucks with bodies that significantly extend beyond the outer sides of the tyres)
- static strength as set out below:

Force at P1 (kN)	Force at P2 (kN)	Force at P3 (kN)
200	150	100

Energy absorbing barrier

- a stroke of at least 300 mm and preferably more.
- minimal distance from the rear of the vehicle to the barrier and preferably no more than 300 mm
- full width out to the outer edge of the tyres or truck body (note that this will be a problem for trucks with bodies that significantly extend beyond the outer sides of the tyres)
- an energy absorption capacity of 50kJ.
- residual strength after full energy absorption, as set out below:

Force at P1 (kN)	Force at P2 (kN)	Force at P3 (kN)
200	150	100

8.3 SIDE UNDERRUN BARRIERS

Research and usage suggests that the strength of the ECE design barriers is satisfactory. However there are other aspects that need improvement.

In particular a clearance under the barrier of 550 mm is much too high to ensure unprotected road users are not run over by the wheels of the heavy vehicle.

Preferably side underrun should not be rails as there is the potential for road users to be caught up in the rails. Tack boxes and other items installed or carried under the tray level should form part of the barrier.

Hence it is recommended the ECE standard be adopted with the changes below:

Allowed style	smooth panels or surfaces only
Underrun clearance	350 mm

MODELLING OF TRUCK-CAR CRASHES

The basic physics of truck car crashes is the billiard ball analogy except that allowance must be made for braking and energy absorption in the crumpling of the vehicles.

Using this analogy it is possible to model various crash situations involving cars and trucks. The scenarios considered were:

CARS IMPACTING TRUCKS

Offset frontal impact into a single axle steer wheel;
Offset frontal impact into a twin steer wheel;
Sideswipe impact into a single dual tyred axle;
Sideswipe impact into a dual tyred tandem axle group;
Sideswipe impact into a dual tyred tri axle group
Side impact into a single steer axle;
Side impact into a twin steer axle group;
Side impact into a single dual tyred axle;
Side impact into a dual tyred tandem axle group;
Side impact into two axles of a dual tyred tri axle group;
Side impact into single steer tandem drive prime mover;
Side impact into twin steer tandem drive prime mover;
Side impact into single steer tandem drive rigid truck;
Side impact into twin steer tandem drive rigid truck;
Side impact into twin steer tri- drive rigid truck;
Side impact into tandem axle group semi-trailer;
Side impact into tri-axle group semi-trailer;
Side impact into tri-tri axle group B-Double;
Heavy vehicle full frontal head on;
Heavy vehicle offset frontal head on;
Heavy vehicle rear end impact with no underrun;
Heavy vehicle rear end impact with severe underrun;
Heavy vehicle off-set rear end impact with severe underrun;

TRUCKS IMPACTING CARS WHERE NOT INCLUDED ABOVE

Primarily these crashes relate to situations where the front of the truck impacts the car in situations other than head on crashes. Scenarios considered are

Impact into the side of a car

Impact into the rear of a car

OFFSET FRONTAL IMPACT INTO A SINGLE AXLE STEER WHEEL

Where there is no bumper located low enough and or wide enough to prevent underrun, the front steer wheel may be impacted directly by the vehicle travelling in the opposite direction.

SINGLE STEER AXLE GROUP

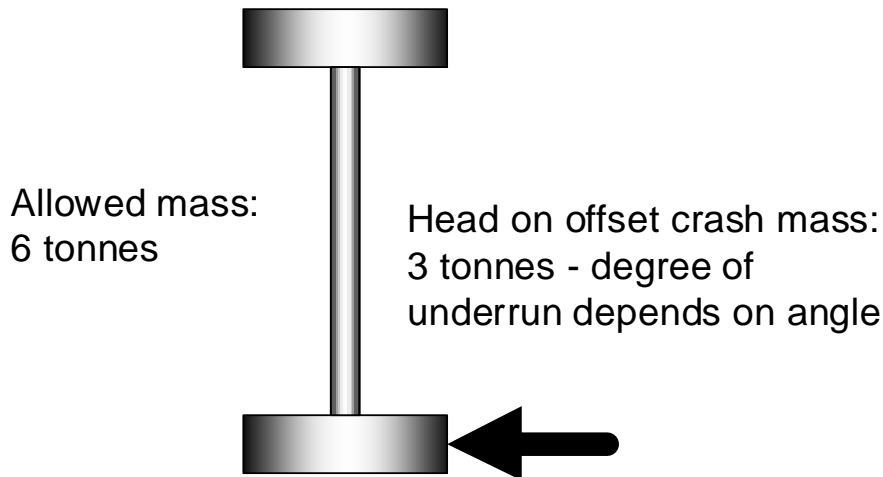

In general this results in loss of the wheel or a compromised steering system. Two examples from Rechnitzer 1992 are shown below. Both these occurred in 100n km/h zones



Effect of underrun on outcomes

Unless the front bumper/bull bar structure is very strong the offset collision will severely distort those and expose the steering wheel to damage. Offset underrun is very likely. This of course exposed the car driver to the possibility of direct contact with parts of the truck.

Separately the truck driver will be exposed to high risk as he will have little or no control of his vehicle so rollover or fixed object crashes will be possible severe risk outcomes.

Policy implications

This data suggests that bumper bar height matching is required, and bumper bar strength should be such as to minimise the risk of steer wheel damage or steering system compromise

OFFSET FRONTAL IMPACT INTO A TWIN STEER WHEEL;

The situation is shown below. In many ways it is similar to the single steer situation except it is unlikely the second axle will be compromised.

TWIN STEER AXLE

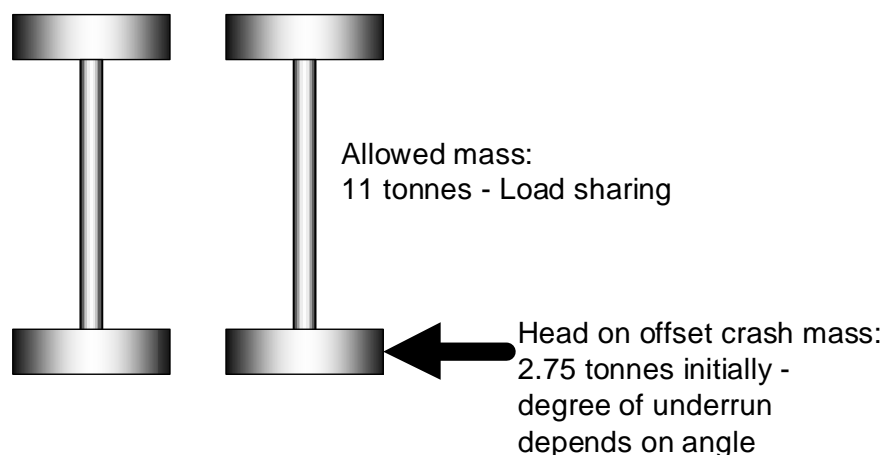

The movement of the front steer axle back into the next axle will assist energy absorption through the energy expended in breaking the first axle away and the deformation of the tyres et cetera. Movements of up to 0.5 metres would be expected.

The numbers of twin steer vehicles is likely to increase in a PBS environment due to the fact that more axles will be valued in respect of minimising road damage. So the frequency of these types of crashes may also increase.

Effect of underrun on outcomes

Will be similar to single steer except the truck driver may still have some control of the steering.

Policy implications

As for single steer situation

SIDESWIPE IMPACT INTO A SINGLE DUAL TYRED AXLE, OR THE LEAD AXLE OF OTHER AXLE GROUPS

This is the situation which is most severe where a vehicle impacts the truck axle when travelling in an opposing direction- loss of control at a curve and running under the side of a trailer.

In general it is trailer axles that are impacted by vehicles travelling in opposing directions as the gap between axle groups is large, and tack storage boxes are usually mounted on the other side of vehicles so the driver is not exposed to risk of being hit by passing vehicles.

SINGLE DUALTYRE AXLE GROUP

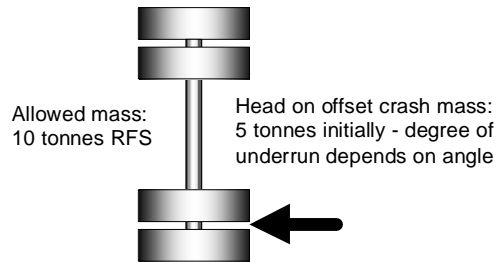

TANDEM DUAL TYRED AXLE GROUP

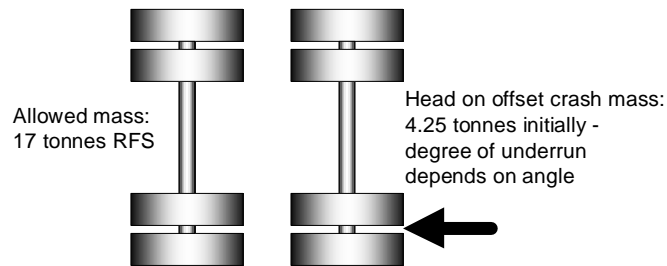

TRIAXLE DUAL TYRED GROUP

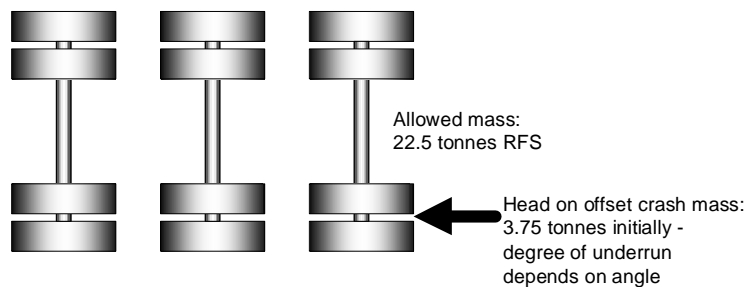

In high speed crashes the suspension adjacent to the point of impact will be destroyed. A single axle will rotate until it jams on the chassis, while the lead axle of a multiple axle group will move back onto the following axle.

Where the clearance under the trailer chassis main beams is low, the light vehicle will be channelled towards the dual tyres

At acute angles the driver of the light vehicle may be at risk from contact with the trailer coaming rail.

Effect of underrun on outcomes

Where the sideswipe involves vehicles travelling in opposing directions, side underrun will expose the car driver to the possibility of direct contact with parts of the truck.

Where the sideswipe involves vehicles travelling in the same directions, side underrun will expose the car passenger side occupants to the possibility of direct contact with parts of the truck.

Policy implications

This supports that devices be fitted which prevent the car travelling under the side of the heavy vehicle.

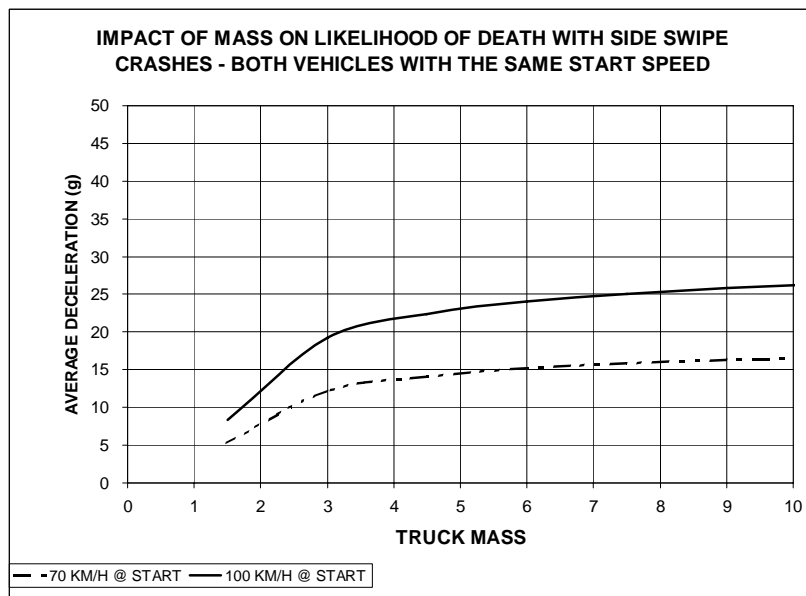
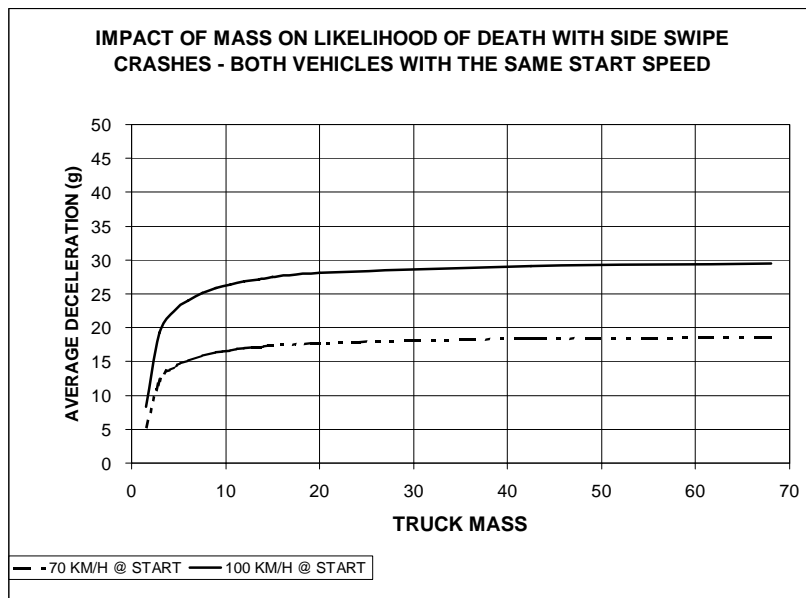

SIDE IMPACT INTO A SINGLE OR TWIN STEER AXLE GROUP, SINGLE DUAL TYRED AXLE, TANDEM AXLE GROUP OR TRI-AXLE GROUP

SINGLE STEER AXLE GROUP

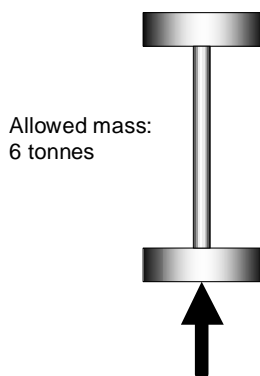

Side on crash mass: 6 tonnes - No underrun - simulates offset or pole type collision

TWIN STEER AXLE

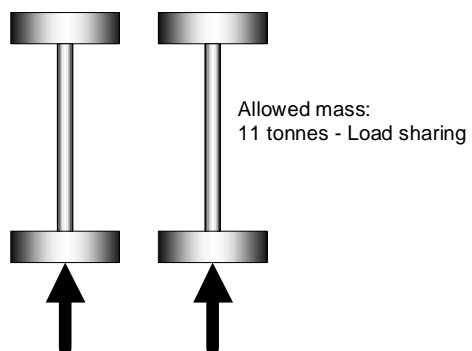

Side on crash mass: 11 tonnes - No underrun

SINGLE DUALTYRE AXLE GROUP

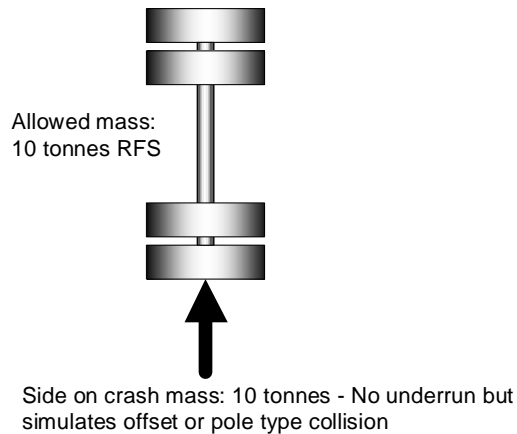

TANDEM DUAL TYRED AXLE GROUP

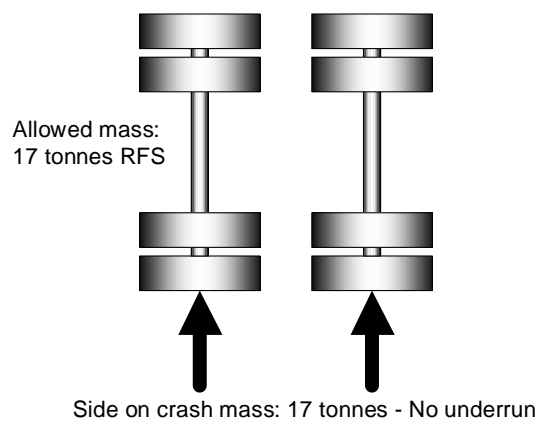

TRIAXLE DUAL TYRED GROUP

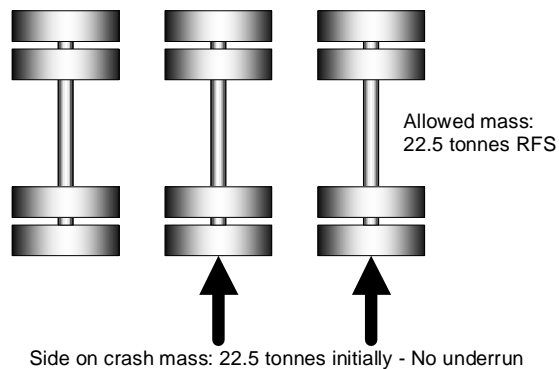

Effect of underrun on outcomes

As there is no underrun possible there can be no impact on these collisions. However where the impact is offset underrun makes these collisions similar to offset barrier collisions

Policy implications

None.

SIDE IMPACT INTO OTHER PARTS OF TRUCKS, TRAILERS AND PRIME MOVERS

A number of these situations are shown below

SINGLE STEER TANDEM DRIVE PRIME MOVER

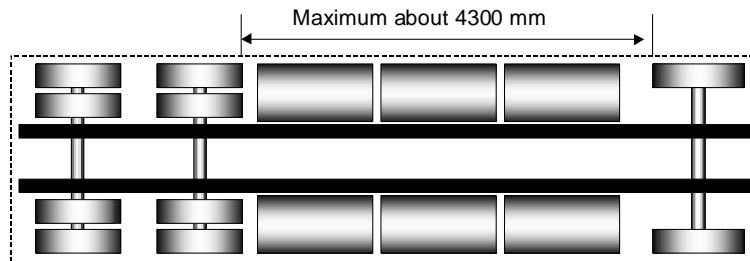

Side on crash mass: up 23 tonnes - Typically no underrun

Often prime movers act as a barrier because there is no real underrun along the vehicles side. However there is a situation that generates some risk being the fact the fuel tanks are directly impacted and may rupture.

TWIN STEER TANDEM DRIVE PRIME MOVER

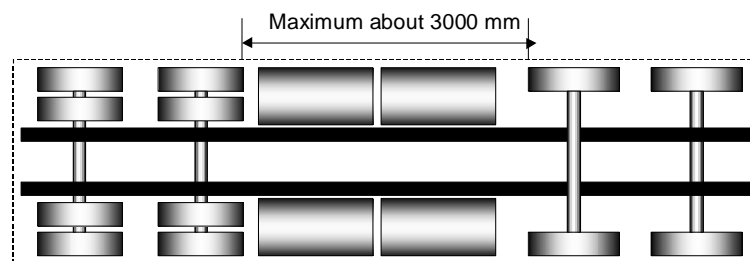

Side on crash mass: up 28 tonnes RFS - Typically no underrun

Similar to the above.

SINGLE STEER TANDEM DRIVE RIGID TRUCK - SIDE UNDERRUN

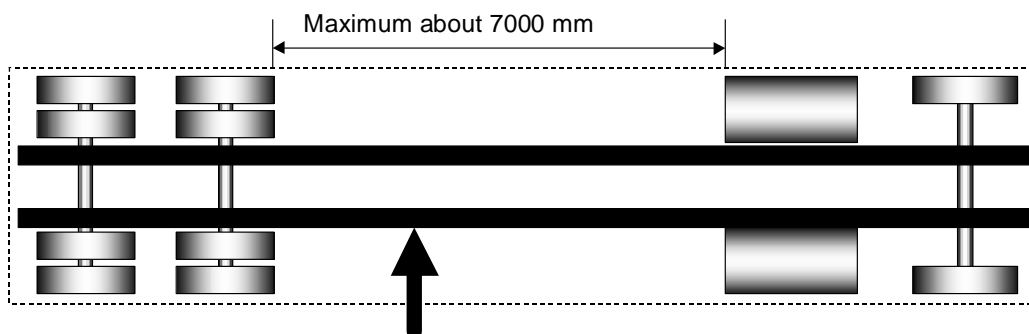

Side on crash mass: up 23 tonnes - Underrun typically 670 mm with duals

Short wheelbase rigid trucks are similar to prime movers and act as a barrier because there is no real underrun along the vehicles side. However longer wheelbase trucks have side

underrun between axle groups and fuel tanks where the clearance from the chassis rails to the outside of the truck is around 670 t 800 mm.

TWIN STEER TANDEM DRIVE RIGID TRUCK - SIDE UNDERRUN

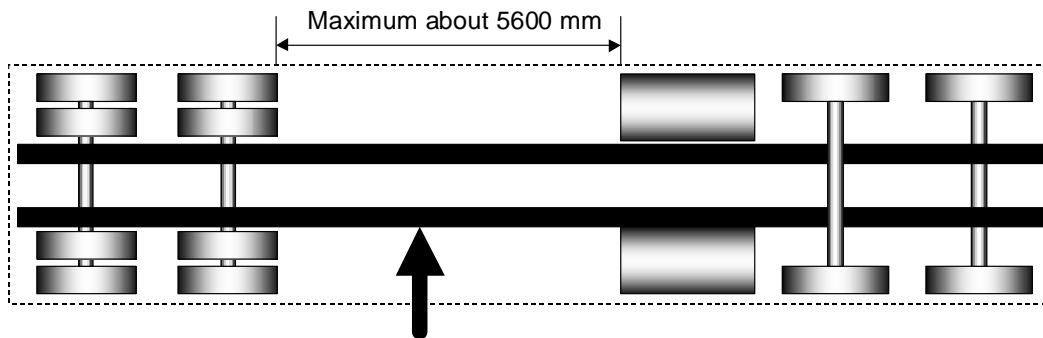

Side on crash mass: up 28 tonnes - Underrun typically 670 mm with duals

Same as above.

TWIN STEER TRI-DRIVE RIGID TRUCK - SIDE UNDERRUN

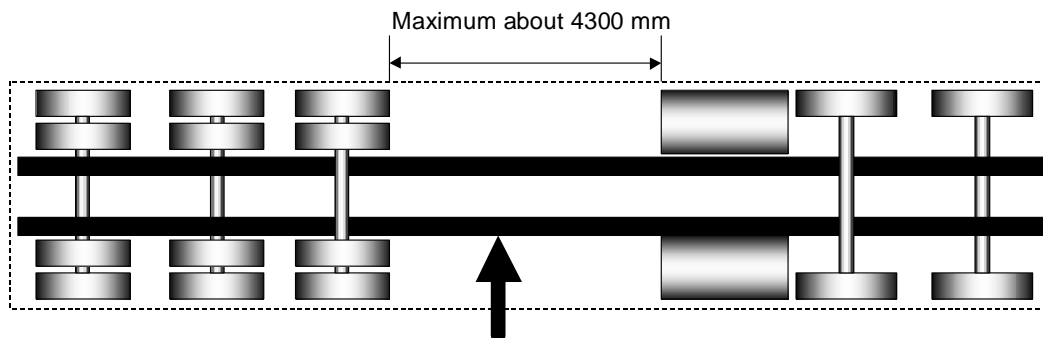

Side on crash mass: up 31 tonnes - Underrun typically 670 mm with duals

Same as above.

TANDEM AXLE SEMI-TRAILER - VOLUME LOADED - SIDE UNDERRUN

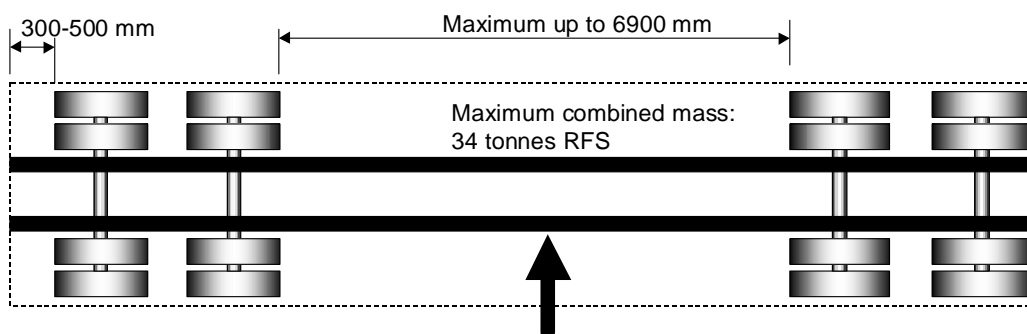

Side on crash mass: up to 34 tonnes - Underrun typically 670 mm with duals

Because of the length of semi-trailers and the absence of fuel tanks et cetera, these vehicles have a high potential for vehicle underrun. In addition if the main chassis rails are high, the front of the light vehicle can underrun them and car occupants can be at risk of directly impacting the trailer chassis beams.

TRI AXLE SEMI-TRAILER - VOLUME LOADED - SIDE UNDERRUN

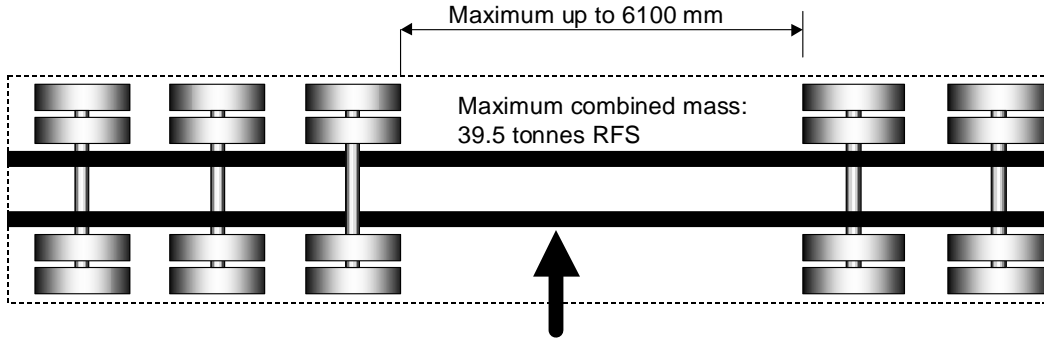

Side on crash mass: up to 39.5 tonnes - Underrun typically 670 mm with duals

Same as above.

TRI-TRI B-DOUBLE - SIDE UNDERRUN

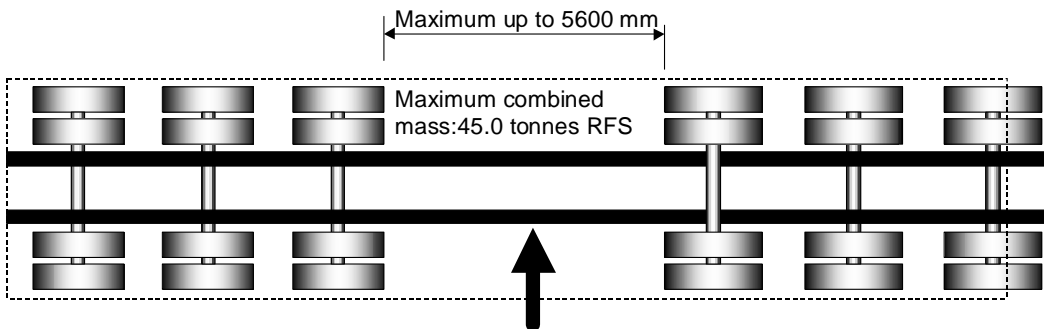

Side on crash mass: up to 45.0 tonnes - Underrun typically 670 mm with duals

Same as above.

Graphs showing decelerations for the situations above are shown below

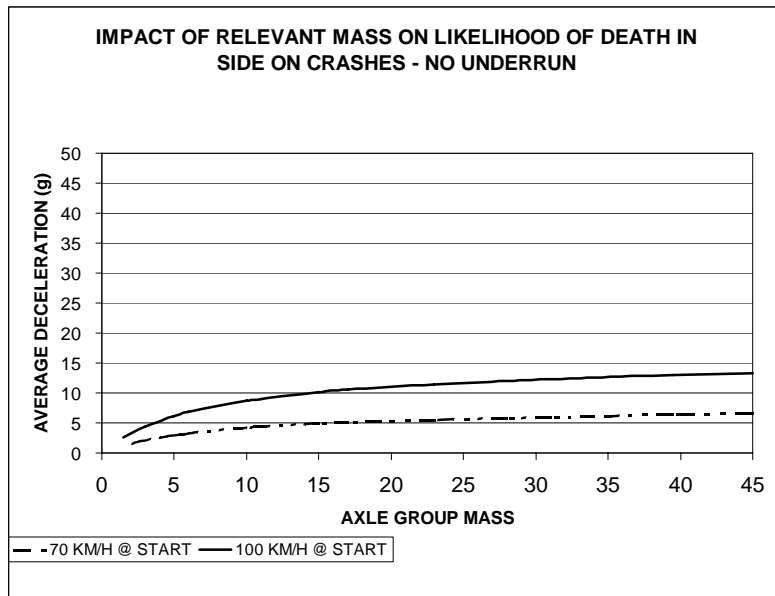

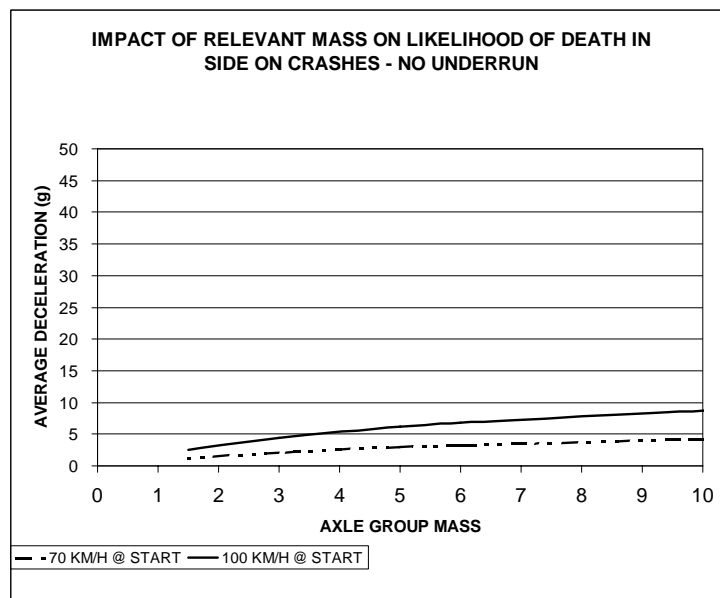

Effect of underrun on outcomes

Where the chassis rails or other parts of the vehicle are low, the approximate 670 mm of underrun compromises light vehicle crashworthiness to some degree.

However where chassis rails or trailer main beams are higher, there is a much more serious situation in that the front of the light vehicle can pass under these beams so that light vehicle crashworthiness may be seriously or completely compromised and the light vehicle occupants will be highly likely to suffer serious if not fatal head injuries.

Policy implications

The need for high clearances for trailers needs to be investigated.

Side underrun protection for these vehicles needs to be considered.

Consideration needs to be given to designing tack boxes, tyre carriers, gate carriers in a way that allows them to serve as underrun barriers.

HEAVY VEHICLE REAR END IMPACT

These impacts often occur with parked heavy vehicles, but may also occur in traffic when vehicles are required to brake heavily.

HEAVY VEHICLE - REAR END IMPACT - NO UNDERRUN

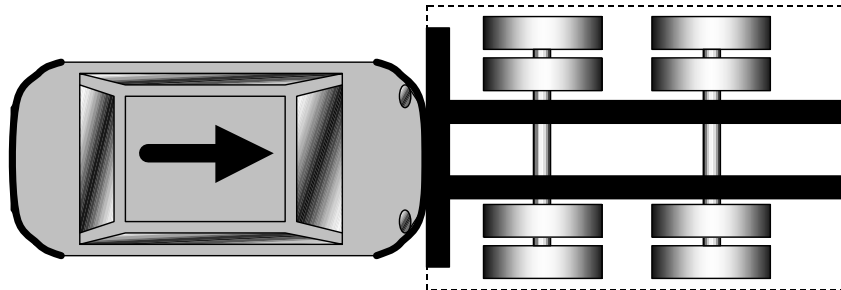

Rear end crash: mass up to 68 tonnes

Where there is an effective rear end underrun prevention situation, the back of the truck acts like a crash barrier. This has been modelled using an excel spreadsheet.

For the model it was assumed that:

- The truck is parked
- The rear of the truck acted as a solid barrier – there was no underrun and no energy absorption;
- The car weighed 1500 kg;
- Braking reduced the start speed of the car by 30% before impact;
- 20% of the total kinetic energy was absorbed in crumpling of the car;
- at 70 km/h the car crumpled 0.78 m and the truck 0.03 m, and
- at 100 km/h the car crumpled 0.90 m and the truck 0.05 m.

The results are shown in the graphs below. The second graph shows the relationship for lighter heavy vehicles.

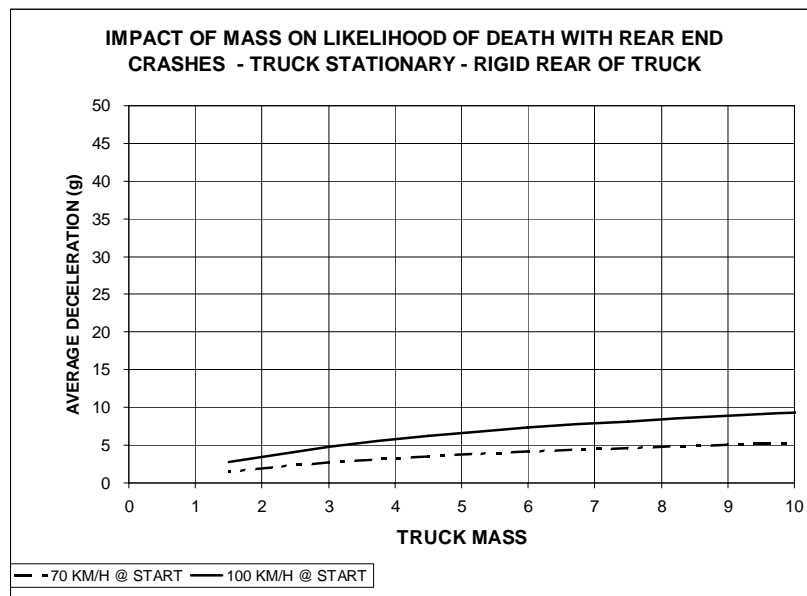
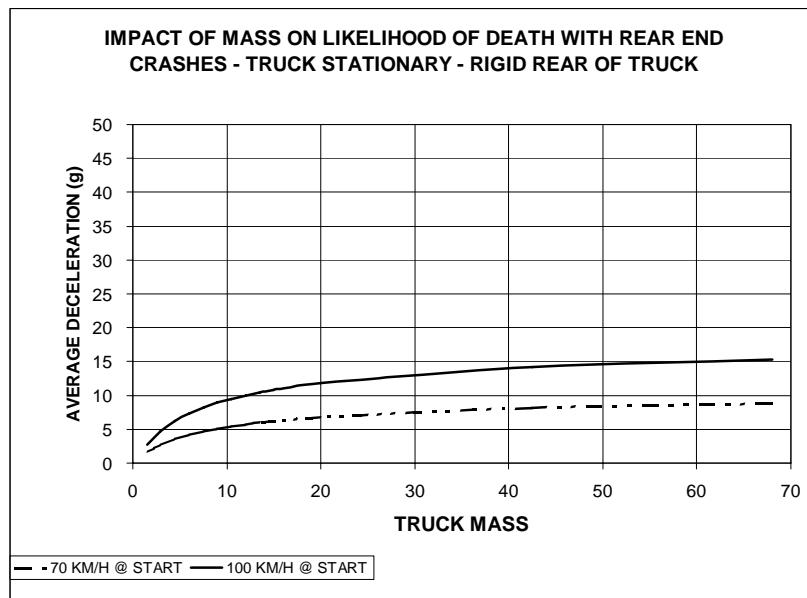

As is shown the chances of fatality due to decelerations alone are much lower than for some other truck-car crashes, with peak average decelerations of about 15 g.

Of course if the truck is in motion the peak decelerations will be lower again.

Effect of underrun on outcomes

HEAVY VEHICLE - REAR END IMPACT - SEVERE UNDERRUN

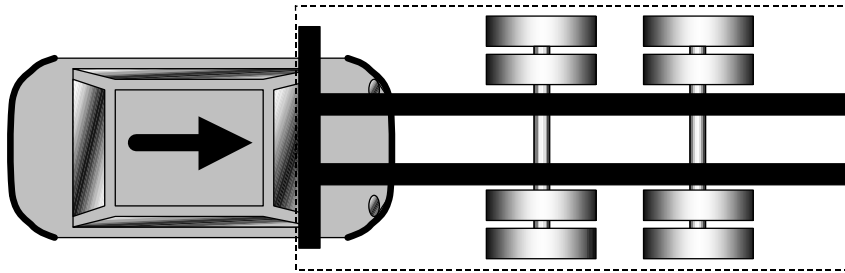

Rear end crash: mass up to 68 tonnes. Underrun up to 3000 mm with single axle; 1600 mm with tri-axle group

Where there was the ability for the car to underrun the rear of the truck, the effect is to severely compromise car occupant safety. Deaths are likely from direct impact with the truck or trailer structure in cases of extended rear overhang.

A question arises as to whether there is a real need for extended rear overhang up to the allowed 3.7 metre maximum.

Policy implications

The need for extended rear overhang needs to be investigated.

Rear underrun designs should be required to extend to the edge of the body of the truck or trailer, to be at the height of car bumper bars, and include an upright at the corner to ensure that the structure of the car is fully engaged with the rear underrun barrier.

HEAVY VEHICLE OFF-SET REAR END IMPACT

These crashes may typically occur where a car driver swerves to avoid hitting the back of a truck or trailer. Where there is significant rear overhang and the rear underrun barrier design is deficient (many current designs are deficient) then severe underrun can and does occur

HEAVY VEHICLE - OFFSET REAR IMPACT - SEVERE UNDERRUN

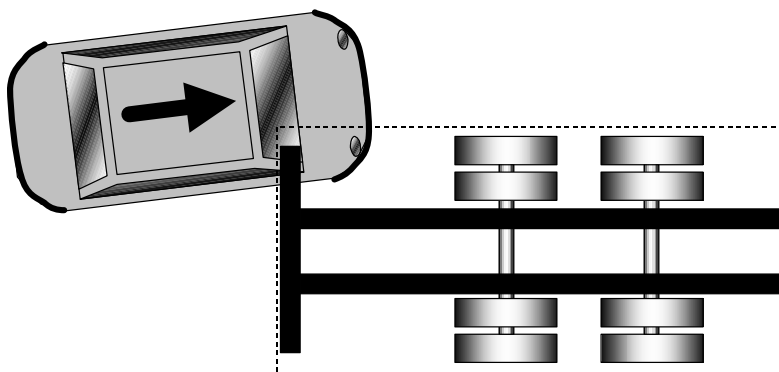

Rear end crash: mass up to 68 tonnes. Underrun up to 3000 mm with single axle; 1600 mm with tri-axle group

Effect of underrun on outcomes

The photos below show the outcomes of two such crashes where the car was able to underrun the rear of the truck



Where there was the ability for the car to underrun the rear of the truck, the effect is to severely compromise car occupant safety. This can be compounded by the car being forced down so that the rear edge of the truck or trailer acts like a guillotine.

Current requirements for rear underrun design only apply to semi-trailers, do not require it to extend full width, allow ground clearances of up to 600 mm, and do not require any upright at the end of the rear underrun bar. Hence the short cantilever end acts like a blunt knife and there is little engagement of the car structure.

Policy implications

Rear underrun designs should be required to extend to the edge of the body of the truck or trailer, to be at the height of car bumper bars, and include an upright to ensure that the structure of the car is fully engaged with the rear underrun barrier.

TRUCK IMPACT INTO THE SIDE OF A CAR

These typically occur when a light vehicle drives in front of a heavy vehicle, often from the left.

HEAVY VEHICLE CRASH INTO SIDE OF CAR

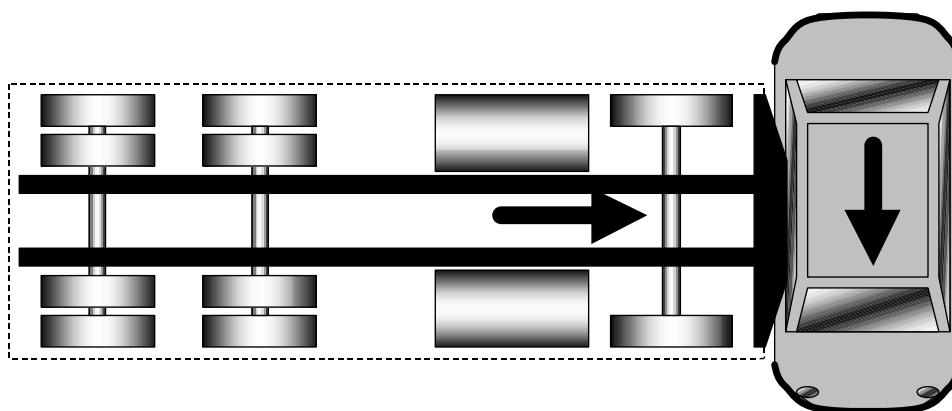

Side crash: Truck into car: mass up 68 tonnes - Overrun depends on height of bumper bar

Where the truck bumper and the car sill heights are matching, the major safety risks are related to the high side acceleration experienced by the car occupants. Death may be caused by damage to the aorta or the spinal column. This was believed to be the cause of all occupants being killed in the vehicle below when the truck bumper collected the sill. The car drove in front of a truck travelling at open road speed.



Additionally there are the effects of crushing of the side of the vehicle and direct contact of car occupant body parts with the unyielding front of the truck or its bumper or bumper bar.

The estimated decelerations are shown below.

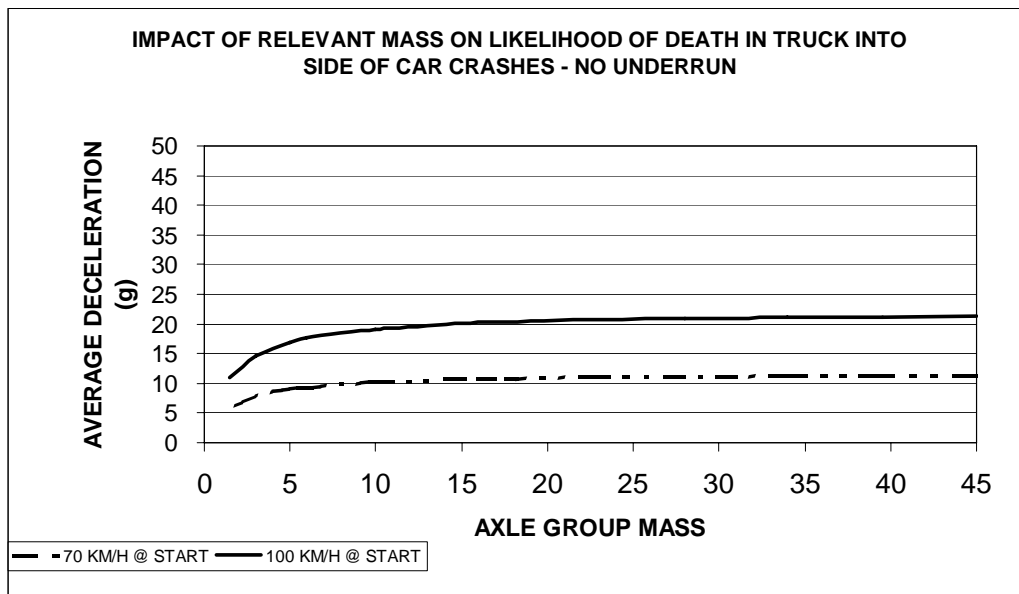

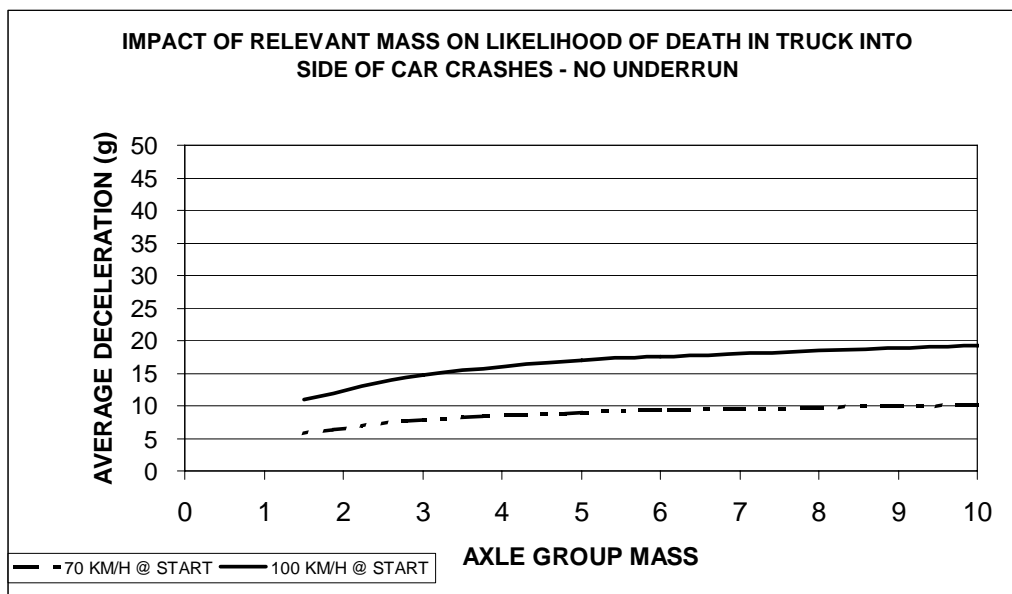

Effect of underrun on outcomes

Where there was the ability for the truck to overrun the car sill, the effect would be to compromise the cars energy absorption and significantly increase the likelihood of intrusions into the cabin space. A further effect is that the vehicle is rotated and can end up being overrun and demolished by the truck. Hence overrun would be likely to increase the chance of fatalities in these crashes.

Policy implications

This crash situation will benefit where bumper bar height and sill height matching exists, and where the truck has no rigid parts at the front which can contact car occupants directly.

TRUCK IMPACT INTO THE REAR OF A CAR

These may occur when:

1. a car is travelling in the same direction and typically cuts in front of the truck in situations where both vehicles need to brake
2. a slow moving car is approached by a fast moving truck where sight distances are short, or
3. a truck impacts with a stationary parked car.

HEAVY VEHICLE CRASH INTO REAR OF CAR

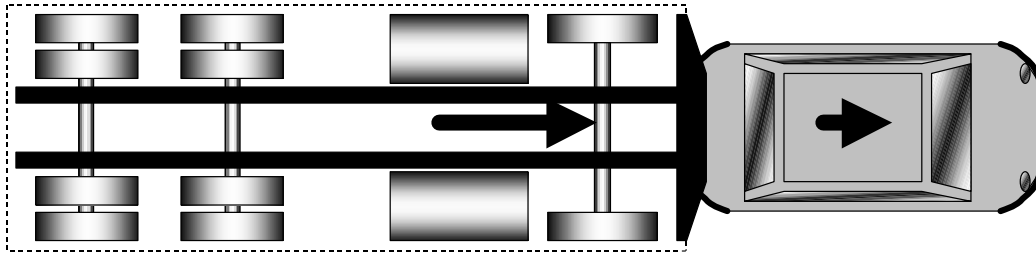

Truck crash into rear of car: mass up 68 tonnes - Overrun depends on height of bumper bar

Where the truck and car bumper heights are matching, the major safety risks are related to the "whiplash" experienced by the car occupants and the effects of crushing of the rear of the vehicle. A particular risk not present in other truck car crashes is the risk of the fuel tank being ruptured and subsequent fire risks.

Effect of underrun on outcomes

Where there was the ability for the truck to overrun the car bumper bar, the effect would be to compromise the cars energy absorption and increase the likelihood of intrusions into the cabin space. A further effect is that the rear of the car is pushed down and so there is an increased likelihood of fuel tank ruptures and of sparks being generated by steel contact with the road surface and hence significant increases in the risk of fire. Hence overrun would be likely to increase the chance of fatalities in these crashes.

Policy implications

This crash situation will also benefit where bumper bar height matching exists

HEAVY VEHICLE FULL FRONTAL HEAD ON;

Head on crash between a truck and car (similar to that shown in the photo below where start speeds were around 100 km/h)

HEAVY VEHICLE FULL FRONTAL HEAD ON CRASH

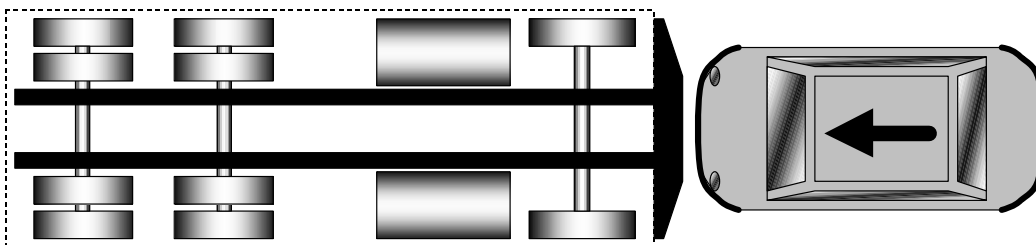

Head on crash: mass up 68 tonnes - Underrun depends on height of bumper bar



For the model it was assumed that:

- The front of the truck acted as a solid barrier – there was no underrun and no energy absorption;
- The car weighed 1500 kg;
- Braking reduced the start speed of both vehicles by 30% before impact;
- 20% of the total kinetic energy was absorbed in crumpling of the car;
- at 70 km/h the car crumpled 0.85 m and the truck 0.05 m, and
- at 100 km/h the car crumpled 1.20 m and the truck 0.20 m.

The results are shown in the graphs below. The second graph shows the relationship for the lighter end of the heavy vehicle GVM's

The key features of those graphs is that a crash outcome is likely to be a fatality:

- in rural areas for heavy vehicles weighing as low as 2.5 – 3.0 tonnes (Average decelerations calculated as 27 – 33 g indicate peak decelerations of 50 g or more);
- in urban arterial road environments for heavy vehicles weighing as low as 4.0 – 6.0 tonnes (Average decelerations calculated as 27 – 30 g indicate peak decelerations of 50 g or more);

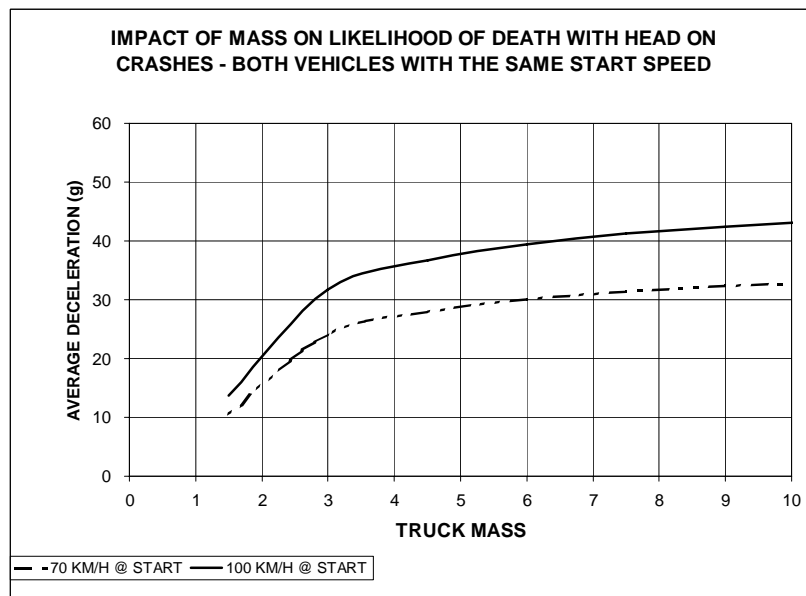
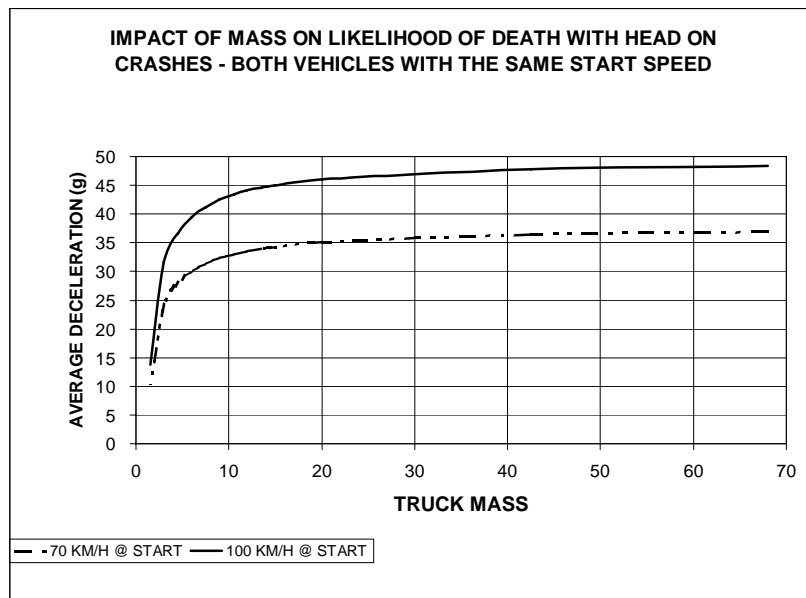

Effect of underrun on outcomes

Where there was the ability for the car to underrun the bumper bar, the effect would be to compromise the cars energy absorption and dramatically increase the likelihood of intrusions into the cabin space. Hence underrun would be likely to increase the chance of fatalities in these crashes.

Policy implications

This data suggests that bumper bar height matching should extend down to the heavier four wheel drive vehicles.

HEAVY VEHICLE - OFFSET FRONTAL HEAD ON;

Offset head on crash between a truck and car. The implications are similar for the full frontal head on except there will be much greater intrusion into the cabin space for the same start speeds, or the car may tend to rotate away from the prime mover thereby reducing injury potential

HEAVY VEHICLE OFFSET FRONTAL HEAD ON CRASH

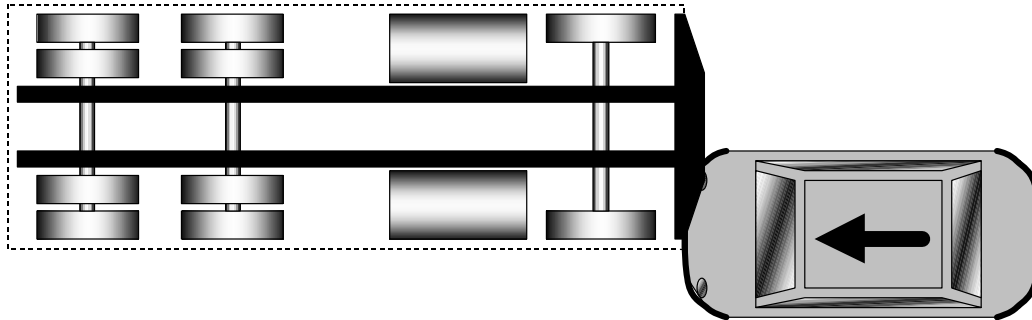

Head on crash: mass up 68 tonnes - Underrun depends on height of bumper bar

Effect of underrun on outcomes

Where there was the ability for the car to underrun the bumper bar, the effect would be to compromise the cars energy absorption and increase the intrusion into the cabin space. Hence underrun would be likely to increase the chance of fatalities in these crashes.

Policy implications

A bumper bar height matching requirement should extend down to the heavier four wheel drive vehicles.

APPENDIX B

LITERATURE SEARCH

TRUCK INVOLVED CRASH STUDY – INTERIM REPORT ON FATAL AND INJURY CRASHES OF CARS AND OTHER ROAD USERS WITH THE FRONT AND SIDES OF HEAVY VEHICLES – GEORGE RECHNITZER FEBRUARY 1993

Involvement of heavy vehicles in crashes

Crashes involving heavy vehicles and other road users are a significant contributor to the total number of people killed or seriously injured in road crashes. In Australia truck-involved crashes contribute 18% of road deaths with around 400 people killed and 1700 seriously injured.

In multi-vehicle crashes, most at risk are the other road user. In Victoria, about 30% of car occupants who are killed or seriously injured in multi-vehicle collisions, are involved in collisions with trucks.

For fatal crashes the involvement rate on a 100 million kilometres travelled basis is over **4.3** times greater for an articulated vehicle than for a rigid truck (7.4 vs 1.7) and over **3.5** times greater for an articulated vehicle than for a car (7.4 vs 2.1).

An analysis of the risk of being killed in truck involved crashes, based on a comparison of the ratio of fatal crashes to total crashes, shows that crashes involving articulated vehicles are **over seven times** more likely to result in a fatality than car only crashes (6.1% vs 0.8%). Similarly for rigid trucks this ratio is **2.3 times** that for car only crashes (1.9% vs 0.8%).

For the 6 year period 1984-1989 the type of Australian road user killed or injured in these crashes was:

Distribution %	injury level	car occupant	motor-cyclist	bicyclist	pedestrian	truck occupant
rigid	fatal	23.0%	5.0	1.54	5.8	5.4
articulated	fatal	33.6	4.0	1.08	4.0	12.9
rigid/artic. crashes	fatal	1.2	0.2	0.1	0.5	1.3
Totals % (number*)	fatal (2968)	58% (1716)	9.3% (277)	2.8% (84)	10.3% (306)	19.7% (585)
rigid	hospital	30.2%	5.4	1.9	4.3	13.9
articulated	hospital	23.2	1.6	0.7	1.4	13.3
rigid/artic. crashes	hospital	1.6	0.27	0.2	0.1	1.9
Totals % (number*)	hospital (12871)	55% (7077)	7.3% (933)	2.8% (357)	5.8% (745)	29% (3759)

From analysis of Australian data, *in a crash involving injury* there is:

a **one in six** chance of being killed when an articulated vehicle is involved - (fatal rate is 0.15)

a **one in twenty** chance of being killed when a rigid truck is involved - (fatal rate is 0.05)

a **one in thirty three** chance of being killed for other crash types - (fatal rate is 0.03)

The distribution of impact position in truck involved crashes is shown below:

Truck-car crashes	Frontal	Trucks into side of cars	Trucks into rear of cars	Cars into rear of trucks	Cars into side of trucks	Side to side impacts	other/ not known	Total
Rigids > 3.5t	14	19	0	11	6	6	14	70
Articulated	57	55	13	7	14	7	21	174
Total Cases	71	74	13	18	20	13	35	244
% (cases)	29%	30%	5.3%	7.4%	8%	5.3%	14.4%	100%
Total fatalities	89	87	19	18	23	13	52	301
% (fatalities)	30%	29%	6.3%	6%	7.6%	4.3%	17%	100%

For Australian fatalities the distribution of road user impact positions was:

Number of cases	Front	Side	Rear	other	Total
truck -bicycle	8 44 %	7 39 %	1 6%	2 11 %	18 100 %
truck -motorcycle	13 35 %	14 38 %	8 22 %	2 5%	37 100 %
truck -pedestrians	32 45 %	29 41 %	6 8%	4 6%	71 100 %
Total	53 42 %	50 40 %	15 12 %	8 6 %	126 100 %

The distribution for Victorian fatal and serious injury crashes was

Truck-car crashes	Frontal	Trucks into side of cars	Trucks into rear of cars	Cars into rear of trucks	Cars into side of trucks	Other	Total
fatal %	52%	24%	4%	9%	6%	5%	100%
serious injury%	46%	14%	8%	17%	10%	5%	100%

In summary, the estimated crash involvement of different parts of the truck are:

- **crashes with other vehicles**
- front of the truck: 66% of fatal; 68% of serious injury crashes
- rear of the truck: 9% of fatal; 17% of serious injury crashes
- side of the truck: 13% of fatal 10% of serious injury crashes.
- **crashes with unprotected road users:**
- front of the truck 42% of fatal crashes
- side of the truck 40%
- rear of the truck 12%

It is clear that the design of the front of the truck to reduce the severity of impact to cars and other road users is the most important, but that for unprotected road users the design of the side of the truck is also important.

Involvement of trucks in fatal and serious injury crashes internationally.

In the USA, although vehicles over 12t make up less than 2% of the vehicle fleet, they contribute some 9% of fatalities. In 1991 3198 people died in articulated vehicle crashes, with 13% of these being truck occupants.

Gloyns (1989) calculated that in Britain 3.8% of car-truck crashes result in a fatality, whereas for car-car crashes the equivalent percentage is 0.8%, a ratio of some 4:1.

For Europe, Goudswaard, Nieber and Janssen estimate that in Europe 1:4 of all road deaths result from truck involved crashes, this is a toll of some 13000 fatalities per annum with some 300,000 serious injuries.

In Germany, Danner and Langweider (1981), determined that for multi vehicle crashes 31% of fatalities involve a HV, which is quite similar to Cameron’s (1991) finding of 30% for Victoria.

The distribution of impact location for fatal car crashes and HVs, was given by Danner (1991) in their sample of some 1400 truck involved crashes. The figures are compared to Australian data

impact type	fatality		injuries	
	Australia	Germany	Victoria	Germany
Frontal	29%	38%	46%	16%
HV into car side	30	29	14	19
car into side of HV	13	8	10	21
car into rear of truck	7	17	17	16
truck into rear of car	5	2	8	17

For fatal crashes involving HVs:

- Australia has more car -truck involvement than in Europe (72% vs 50% involve cars)
- Australia has less pedestrian involvement (13% vs 21% involve peds.)
- Australia has less two-wheeler involvement (15% vs 28% involve 2-wheelers)

Frontal design of trucks

Sweden:

In Sweden, Hogstrom and Svensson (1986) of Volvo, in their study of over 1000 truck involved crashes, noted that the front of the truck is involved in some 77% of fatal crashes.

Germany:

Danner and Langweider (1981) in their study of 1559 truck involved crashes and a series of ten crash tests, found that the “...*high mass of the truck does not constitute the only dominant problem in the severity of real life accidents. Another major factor is the form aggressivity of the truck front, which may be reduced by technical means.*”

Danner (1981) estimated the typical impact speeds to be:

- frontal crashes- 50% = 60 km/h,
- truck into side of cars- 70% < 30 km/h; and 90% < 45 km/h
- trucks into the rear of cars- 90% < 25 km/h
- car into rear of truck- 70% < 40km/h

They also concluded from this study that although there were numerous collision types and variations, these could readily be classified into six major categories:

- frontal
- offset frontal
- truck into side of car
- angled truck impact with side of car
- car into rear of truck
- car into rear of truck, offset

In continuing research, Langweider and Danner (1987) investigated 1200 truck (>3.5t) involved crashes, with the objectives of setting priorities for the active and passive safety of trucks. They concluded that "*truck front protection in collisions with cars and side guards for pedestrians and motorcyclists are of paramount importance*".

Netherlands:

In the Netherlands, Goudswaard et al (1991) found that in Europe that between 50% and 65% of the fatally injured in truck crashes (>7000 people) are car occupants. Of these car occupants, 60% (> 4200 people) are killed in truck front to car front crashes.

The average relative speed in injury cases, frontal crashes, (in effect delta V for the car) is estimated to be 65km/h. They also noted that 25% are collisions with the side of the truck and 15% with the rear of the truck.

They noted that the three basic properties which make the truck so "aggressive" to car occupants:

- the high mass difference,
- the high truck stiffness leaving most of the energy absorption to the car; and
- the geometric incompatibility between the car and truck structures

Great Britain

In Britain, Mackay and Walton (1984) reviewed 226 in depth crash studies. They found the following distributions for impact position

Impact position on HV	%
front of truck	63%
side	11%
rear	18%

Gloyns and Rattenbury (1989), found that in car-truck crashes, 75% of the car fatalities involved the front of the truck. Of these crashes 2/3 were frontal crashes and 1/3 were the truck into the side of the car. Crash characteristics were:

- typical fatal frontal crash is offset
- high levels of intrusion in majority of cases
- in 70% of cases intrusion extends into passenger area with occupants suffering severe head and chest injuries.

Gloyns estimated that front and rear underrun barriers would reduce fatalities by some 17%.

Riley et al (1981), referring to their study of 740 crashes occurring in 1976, estimated that 41 lives out of the 150 fatalities, would have been saved by the fitting of energy absorbing underrun guard.

Riley et al (1987), described the different mechanisms involved in a frontal collision between a car and HV. Without an underrun guard the trucks bumper contacts the car at a high level and rotates the engine upwards about a transverse axis. This causes a downward load on the car such that the front of the car is forced down until the sill beam under the A pillars contacts the road surface, resulting in increased overrun. Their terminology for this action was the "jacking effect".

Robinson and Riley (1991) in a recent paper examined police accident records for 800 fatal crashes involving HVs. They concluded that the fitting of an energy absorbing front underrun protection device (FUPD) would have saved 80 lives

Thomas and Clift (1988) also of TRRL, reviewed a sample of Police reports on fatal crashes involving HVs. They found that underrun was involved in some 88% of their sample, and in 75% of the cases the energy absorbing capacity of the car's main chassis members was not utilised. They found that high levels of intrusion were common in frontal collisions, with the A pillar contacted in 58% of cases:

deformation in frontal crashes	%		intrusion in side impacts	%
none	2%		none	-
up to A pillar	40%		0.5 seat width	38%
up to B pillar	24%		full seat width	42%
beyond B pillar	29%		> full seat	13%

Side design of trucks

In Australia in his 1966 study of 59 crashes involving trucks, in the city of Adelaide, Mclean (1966) suggested the fitting of both rear underrun barriers and side skirts to trucks to reduce the injury potential for these crash types.

In Sweden, Hogstrom and Svensson (1986) of Volvo, have studied over 1000 truck involved crashes, since 1970. They concluded that side skirts would have a positive effect in 35% of crashes involving cyclists and motorcyclists.

In their 1976 study of 740 fatal crashes in Britain, Riley et al (1981), of the 300 fatalities involving unprotected road users, two thirds of these involved impact with the side of the HV. Of these, 98 were run over by the rear wheels. Their estimate is that side skirts would have saved 39 two wheelers and 14 pedestrians.

Otte (1987, Germany), in an in-depth at scene crash study of 325 crashes involving HVs >3.5t, noted that for two wheelers 48% involved the front of the truck and some 20% of crashes were with the side of the truck. Otte stated that "*...the side is especially dangerous due to protruding, often edgy structures and the possibility of running or driving under the vehicle*". Otte found that 22% of the injuries to two-wheelers and 27% of pedestrians resulted from being run over by the wheels. They recommended the incorporation of deformable front structures on trucks and the use of side panels to prevent 2-wheelers from driving under the vehicle between the axles. They also noted the need to have the impact points being at the same level as the energy absorbing structures on the cars and two wheelers.

In Germany Langweider and Danner (1987), noted that a significant number of side impacts could be described as "glancing", such as can occur during overtaking manoeuvres. The injury causing mechanism is not the speed but the danger of the subsequent fall into the space between the front and rear axle, resulting in being run over by the truck's wheels. They found that side-underrun protection would influence around 50% of serious and fatal injury cases to drivers of two wheeled vehicles. In particular these guards would totally avoid the falls between the wheels. They recommended that side panels should be designed with flat surfaces covering the whole side area. This contrasts with other designs which employ side rails with gaps between them, which can present their own hazards as people can still be caught between the rails.

Langweider and Danner examined 110 accidents involving pedestrians, finding that 42% were with the front of the truck and 33% with the side. They recommended that the design of the front and side should present flat surfaces, without protruding edges, and particularly noted the need for this between the truck's cab and the load platform. They also noted that two-thirds of truck crashes are at speeds less than 30km/h and that the suggested measures of incorporating FUPDs and side skirts, would therefore be effective. {Also noted was the value of anti-lock brakes to help slow and manoeuvre the truck to either avoid any potential crash or reduce impact speeds.}

Proposed new European (ECE) Regulations for front underrun protection

A proposal for a draft new regulation is being developed by the Economic Commission for Europe (ECE) for *Front Underrun Protection on Category N vehicles* (refer Appendix 2) and provides a valuable model for possible Australian standards.

The regulation relates to vehicle categories N2 (3.5t to 12t GVM) and N3 (>12t), and its objective is to prevent underrun from the front by passenger cars and light commercial vehicles. Vehicles excluded from this requirement are those whose design is incompatible with the provision of an underrun barrier. The vehicle can comply with the regulation by either fitting a special front underrun protective device, or be designed such that the characteristics of its front structure can be regarded as replacing the front underrun protective device. A summary of the key technical details specified in the regulation are:

- the unit can be adjusted in position by the operator, if necessary.
- cross member to have a section depth of at least 100mm for category N2 vehicles, and 120mm for category N3 vehicles.
- maximum ground clearance to be 400mm, unladen.
- the barrier must remain within 400mm of the vehicle's front, at all stages.
- the barrier is to be test loaded at points P1, P2, P3, sequentially:
 - P1 is located 200mm from outer faces of front wheel.
 - P2 is located 350mm to 600mm either side of the centreline.
 - P3 is located on vehicle centreline.
 - The heights of points P2 and P3 must not exceed 445mm.
- Force at P1 = 50% GVM with a maximum of 80kN.
- Force at P2, P3 =100% GVM with a maximum of 160kN.

Apparently these force requirements are intended to apply only to vehicles exceeding 7.5t GVM.

Comments on proposed ECE regulations for front underrun protection.

Although a maximum deformation of up to 400mm is permitted, the barrier could be regarded as essentially rigid, as no explicit energy absorption requirements are specified.

The maximum test loads given would apply to trucks of 16t GVM and greater. For smaller trucks, using the forces based on truck mass would result in some very low and possibly ineffective values, as shown in Table 5.2, below.

Truck mass GVM	Force at P1 (& P3) =50% of GVM (kN)	Force at P2 =100% of GVM (kN)
7.5t	38	75
12.5t	63	125
≥16.0t	80	160

Comparison of barrier test load requirements

The following table (Table 5.3) is a comparison of the barrier load test requirements for the ECE frontal and rear underrun protective devices, and the proposed Australian rear underrun requirements (Rechnitzer, 1991, 1993)

Test Load (kN)	ECE: draft- FRONT*	E.C.E: Rear barrier R58**	Australia: Rear underrun barrier - proposed	
truck size GVM	>7.5t	>3.5t	3.5t to 12t	>12t
outer edge P1	80	25	100	100
centre P3	80	25	100	100
off centre P2	160	100	100	150

Notes:

- * These test loads apply to vehicles with a GVM >16t, for other vehicles lower values are permitted and are a function of vehicle GVM.
- ** These test loads apply to vehicles with a GVM >20t, for other vehicles lower values are permitted and are a function of vehicle GVM.

The force at P1 represents loading due to offset collisions (which are over 50% of frontal crashes). The maximum specified value of 80 kN is a little less than the 100kN recommended for rear underrun barriers in suggested Australian standards, however a front barrier would tend to have higher loading than a rear barrier. This comparison suggests that the specified loading for offset impacts (P1) should be increased from 80kN to at least 100kN minimum, for all mass categories of HVs.

The 160 kN primary load (P2) though substantial, is perhaps a little low for vehicles in excess of 12t GVM. For vehicles less than 12t, the minimum loads specified (Table 5.2) would appear to be unrealistically low for an effective barrier: loads can remain a function of mass but with a minimum value specified in the order of 125kN.

Calculation of effect of energy absorption requirements and effect on vehicle forces and accelerations

In a major review of the feasibility of fitting energy absorbing front guards to HVs, Murray (1988), calculated the effects of providing energy absorption capabilities to the front of trucks. In his review Murray concludes that there appear to be limited benefits in providing energy absorption on trucks. This view is based on the apparent need for devices to have significant levels of energy absorption before any difference on crash severity becomes apparent, at least according to theory. Murray however goes on to state that if energy absorbing guards are to be specified these should have an energy absorption capacity of

100kJ, with a stroke of 500mm, based on an average force capacity of 200kN, and compatible with the frontal stiffness of cars. Indeed Murray notes the difficult problem of trying to optimise the guard for small and large cars, and cars with different frontal stiffness.

Benefits of a 100kJ barrier

An examination of the results for a 100kJ barrier shows that quite significant improvements are evident for both the light car and the medium weight (1400kg) car. For example a closing speed of 66km/h (which was the average according to the German research), becomes equivalent to 50km/h rigid barrier impact- which is the design speed for "survivable crashes". Tests carried in Germany were based on the honeycomb barrier (Figure 5.5) with an energy absorption capacity of 100kJ, using a nominal crush of 500mm.

Overall it would appear that energy absorbing barriers are effective over the range of speeds that overseas research has shown the majority of crashes to occur. However these barriers should have a capacity of at least 100kJ.

Summary: Characteristics of the Ideal front underrun barrier

Based on the preceding analyses, the in-depth crash investigations carried out for the project, the review of overseas research, testing and regulations, it would appear that the ideal front underrun barrier would have the following characteristics:

- a stroke of 500 to 600mm.
- a road clearance of not more than 350mm
- an energy absorption capacity of 100kJ.
- a frontal projection of at least 300mm to provide a buffer space in impacts with the sides of cars, and hence reduce the opportunity for direct head and body contact.
- curved at the ends to reduce concentrated loads being applied in angled collisions.
- progressive crush which starts off “soft” for impacts with unprotected road users and the side of cars, and increases progressively to suit frontal impacts with a range of cars.
- residual strength after full energy absorption, as set out below:

Truck mass GVM	Force at P1, P3 (kN)	Force at P2 (kN)
3.5t to 12t	100	1.6xGVM (125 min.)
> 12.5t	100	200

Side design of heavy vehicles

Walz et al (1990) in their review of truck involved crashes recommended the fitting of flat panel side guards to all trucks. They recommend that ECE regulation R73 should be adopted by all countries as soon as possible. Retrofitting of side guards to existing vehicles was to be compulsory.

Riley et al ((1985) in their work at TRRL recommended fitting of side panels to all new vehicles and retrofitting to some existing larger semi-trailers. The side guard should have a maximum ground clearance of 300mm, and mounted flush with the load platform edge.

British and ECE Regulation (R73) for the provision of lateral protection on Goods vehicles, trailers and semitrailers.

The regulations are applicable to vehicles and trailers greater than 3.5 tonne gross mass. Their objective is to offer effective protection to unprotected road against the risk of falling under the sides of the vehicle and being caught under the wheels.

The major technical requirements of R73 are:

- the side guard can consist of a flat panel, or of one or more side rails.
- if side rails are used- the maximum spacing is 300mm the minimum rail width is 50mm for category N2 and O3 and 100mm for category N3 and O4
- the lower edge of the side guard shall be a maximum of 550mm above the ground
- the side guards shall be essentially rigid, and able to withstand a horizontal static force of load of 1kN, applied at any point on the guard.

The regulations also set out detailed dimensional requirements at the sides and ends of the side guards.

The British Standard sets out detailed requirements for the guard dimensions, similar to the ECE requirements. A major difference noted is the specification of a 2kN test load compared with the ECE test load of 1kN.

Recommendations On Side Guards

Currently all buses have lightweight side guards, designed and built as part of normal bodywork. It is evident from inspection of these structures that they are able to sustain significant impacts from vehicles, let alone unprotected road users. The ECE and British regulations have fairly low test load requirements (1 to 2kN), and the author is not aware of any references which have commented on the strength of the guards.

Based on the cited research and testing, and the detailed crash investigations undertaken, improvements to the ECE regulations would require:

- lowering the ground clearance to around 350mm. This may have to be increased for some vehicles to take into account special clearance requirements.
- flat panel surfaces only, with railings not permitted (refer Figure 5.8).
- side panels are to be flush with side structure
- framing for the side guard to be so constructed and detailed to preclude the possibility of spearing car occupants in offset impacts or unprotected road users. Generally this will require a curved return at the start and end of the guard.

- all exposed edges to be radiused (say 20-50mm) to reduce edge loads on unprotected road users.
- adoption of the British load test of 2kN. As this is quite a small load, review whether a higher load is justified for effective performance.

Conclusion and Recommendations

The study identified that the frontal, side, and rear design of trucks *can* be significantly improved to reduce the harm potential in crashes involving other road users. This is in line with European findings. It was noted that the mass aggressiveness is aggravated by the shape, height and stiffness of the HV. The *design* of current heavy vehicles *makes few concessions* with regard to the reduction of crash forces on the occupants of light vehicles, or unprotected road users.

Australia currently has *few requirements* dealing *frontal aggressiveness, side underrun, and rear underrun*. This contrasts with various European countries which have had regulations in place for some time for side and rear barriers, and more recently are reviewing regulations for front underrun barriers.

The general aspects of heavy vehicle design which contribute to the high level of fatalities and serious injuries in crashes involving other road users were found to be:

1. High ratio of mass of truck to car combined with the high stiffness of the truck structure results *in little energy absorption by the truck structure*.
2. *Size incompatibility of truck structures with those of other road users*. This allows underrun by cars and other light
3. *Potential for direct occupant contact with unyielding parts*.
4. *Unguarded wheel areas of the truck* which allow pedestrians and cyclists to fall under wheels and suffer crushing injuries.
5. *Trim on trucks (particularly vans) which can be dislodged* in crashes and spear car occupants.

Other specific conclusions regarding heavy vehicle design are:

HV front bumper performance in collisions:

- The heavy bullbars on most articulated trucks are sufficiently low to prevent underrun in lower severity impacts. The main bumper is generally too high for this to be effective in preventing underrun in higher speed impacts.
- These bullbars help protect the truck's steering system and front wheels from the impact, thus helping the driver to retain vehicle control.
- In offset frontal and side impacts, bullbars are a major hazard to the other vehicle occupant as they intrude directly into their head space and can result in direct head impact.
- Bullbar structures are not energy absorbing.

- Bullbars are a major hazard in impacts involving unprotected road users: they are the antithesis of designs aimed at minimising the risk of injury.
- Bumpers on rigid trucks typically allow underrun as they are mounted too high and have low strength. They afford no protection to the steering system or front wheels which can be torn away by the impacting car.

Height of the truck tray or cab floor: The stiff floor structure of most trucks is sufficiently high to cause serious or fatal injury to the occupants of cars in an underrun situation.

Underrun can be a low speed hazard: At relatively low high occupant compartment intrusion can result.

Occupant protection systems may become ineffective in underruns: Underrun *negates* the effectiveness of vehicle occupant protective, and is more likely to result in direct occupant impact with the truck structure, with consequent severe or fatal head and chest injuries.

The occupant protection performance of cars could also be upgraded as it is the *interaction* between the two vehicles that leads to the resultant injury severity. Improvements to car design could include:

- improved design for offset frontal crashes.
- strengthening side structures requiring dynamic side impact tests, and the incorporation of appropriate interior energy absorbing padding (or side airbags).
- improving interior design by eliminating brittle plastic materials near occupant contact zones.
- improving levels of occupant protection for frontal impacts (eg air bags), and padding of interior contact surfaces (A and B pillars, roof headers).
- modifying the front chassis structure of cars to be more compatible with truck structures by adding a simple “override bracket” incorporated on the car’s chassis behind the front bumper.

Estimated benefits of modifications to truck design

The estimated annual benefits for Australia are set out in the following table.

crash type	current average fatalities	Expected reduction in fatalities %	Estimated reduction in fatalities per annum	Estimated reduction in injury severity for injury cases
car-truck	288	15%+	43	30%
pedestrian-truck	51	20%	10	25%+
two wheeler -truck	60	20%+	12	25%+
Total	399	16%	65	28%

Recommendations

These included

- (1) Trucks, trams and buses be fitted with energy absorbing front barriers a stroke of 500 to 600mm, a road clearance of not more than 350mm, an energy absorbing capacity of 100kJ, a frontal projection of at least 300mm to provide a buffer space in impacts, curved at the ends to reduce concentrated loads being applied in angled collisions, progressive crush which starts off “soft” for impacts with unprotected road users and increases progressively to suit frontal impacts with a range of cars, and residual strength after full energy absorption.
- (2) Rigid trucks and semi-trailers be fitted with side guards, having a ground clearance of around 350mm, flat panel surfaces only forming a "continuous surface", with railings not permitted, side panels flush with side structure, framing for the side be so to preclude the possibility of spearing of car occupants or unprotected road users, and adoption of the British load test of 2kN.
- (3) The front structures of trams and buses incorporate special energy absorbing pads to reduce injury potential for pedestrians and other unprotected road users.
- (4) The design of truck cabs and bodies be improved to reduce their harm potential by eliminating sharp edges, projections, and trim which can spear other road users.
- (5) The conspicuity requirements for the side and rear of trucks be improved.

A STUDY OF THE HEAVY TRUCK TO LIGHT VEHICLE ACCIDENT ENVIRONMENT

U.S. Department of Transportation. - National Highway Traffic Safety Administration - DOT HS 808 477 Final Report January 1996

Prasad. Alope K., Guglielmi. John P., Monk. M. W.

Performing Organization Report No. VRTC- 81- 0198. National Highway Traffic Safety Admin. Vehicle Research and Test Center, P O Box 37, East Liberty. Ohio 43319

Abstract:

Each year approximately 4,000 passenger car and light truck (hereafter referred to as light vehicle) occupants are killed in collisions with medium and heavy trucks (hereafter referred to as heavy truck). Another 120,000 are injured in those types of crashes. A majority (701;) of those collisions involve the front structure of the truck impacting the front, side, or rear of the other vehicle in the collision. Most of these crashes occur on roadways with relatively high posted speed limits (> 45 mph)

In the past, it has generally been assumed that this type of collision was un-addressable due to the large mass differential between the two vehicles involved, and the relatively high speeds. Recent studies have noted, however, that geometric mismatches between the collision partners, as well as the unusually stiff and rigid structure of the heavy truck contribute to the lethality of these collisions.

This report presents the results obtained to date from a pilot study involving the analysis of heavy truck-to-light vehicle accident data. A total of 43 serious (AIS>3) and non-serious accident cases involving the front of heavy trucks impacting the front or sides of a light vehicle were reviewed. The variables examined included vehicle damage, presence and amount of override, collision angles, principal direction of force (PDOF), intrusion, AV, occupant injury, source of injury, restraint use, etc. An assessment was also made after examining the above if lowering, softening, or changing the shape of the heavy truck front would have mitigated the injuries to light vehicle occupants.

REDUCING HEAVY TRUCK AGGRESSIVITY IN COLLISIONS WITH PASSENGER CARS

U.S. Department of Transportation - National Highway Traffic Safety Administration – DOT HS 808 476 Final Report. July 1996

Prasad, Alope K., Clarke, Robert M., Willke Donald W. Monk. Michael W.

Performing Organization Name and Address: National Highway Traffic Safety Admin. Vehicle Research and Test Center P.O. Box 37, East Liberty. Ohio 43319

Abstract

Each year approximately 4,000 passenger car and light truck (hereafter referred to as light vehicle) occupants are killed in collisions with medium and heavy trucks (hereafter referred to as heavy truck). Another 100,000 are injured in those types of crashes. A majority (70%) of those collisions involve the front structure of the truck impacting the front, side, or rear of the other vehicle in the collision. Most of these crashes occur on roadways with relatively high posted speed limits (> 45 mph).

In the past, it has generally been assumed that this type of collision was not addressable due to the large mass differential between the two vehicles involved and the relatively high speeds. Recent studies have also noted that geometric mismatches between the collision partners, as well as the unusually stiff and rigid structure of the heavy truck contribute to the lethality of these collisions.

This report describes the research and testing being performed at NHTSA to study the aggressivity of heavy trucks in collisions with passenger cars. A detailed analysis of NASS accident hardcopies was performed separately to study the distribution of impact geometries and speeds of accidents involving heavy trucks and passenger cars. The front impact mode between heavy trucks and cars was found to be the predominant impact configuration in such collisions. It was therefore decided to study various impact modes involving truck and car fronts

Executive summary

Each year approximately 3,800 passenger car and light truck (hereafter referred to as light vehicle) occupants are killed in collisions with medium and heavy trucks (hereafter referred to as heavy truck). Another 100,000 are injured in those types of crashes. A majority (70%) of those collisions involve the front structure of the truck impacting the front, side, or rear of the other vehicle in the collision.

In the past, it has generally been assumed that this type of collision could not be addressed due to the large mass differential between the two vehicles involved. Recent studies have also noted that geometric mismatches between the collision partners, as well as the unusually stiff and rigid structure of the heavy truck contribute to the lethality of these collisions.

This report describes the research and testing being performed by the Agency to study the aggressivity of heavy trucks in collisions with passenger cars. A detailed analysis of the NASS accident hardcopies was performed separately to study the distribution of impact geometries and speeds of accidents involving heavy trucks and passenger cars. "The front impact mode between heavy trucks and cars was found to be the predominant impact'

configuration in such collisions. It was therefore decided to study various impact modes involving truck and car fronts.

The testing conducted to date indicates that the best method for ameliorating the severity consequences of these types of collisions may be to partially absorb some of the crash impact energy, and then deflect the impacting light vehicle without severely damaging it while the two vehicles are in contact. This appears to be the only potentially practical approach to addressing this crash type, since tests conducted indicate that there is simply too much crash impact energy involved with a heavy truck, travelling at speeds at which they typically operate, to dissipate that energy through vehicle crush and absorption.

Discussion of results

There were a total of twelve baseline tests conducted. The primary observation from the baseline tests conducted with a truck frame with small bumper overhang (4 inches beyond the front of the truck tire) and no cab, was that the interaction of the car with the truck axle and tire played a significant role in greatly reducing the crash impact severity. There was significant override of the car bumper. However, the contact with the truck tire, and the climbing of the truck over the car engine compartment resulted in a significant reduction in the severity of the crash pulse on the car. Absent a truck cab, the short truck bumper overhang did not result in extensive intrusion of the truck bumper into the car occupant compartment. In most cases, there was some intrusion because of the movement of the steering column or the instrument panel/firewall. However, the restraints on the dummy prevented any severe injury readings. These results were not anticipated, nor did they reflect damage patterns seen in real crashes.

On the other hand, when the 55 mph, 50% offset (on the car) test was run using a truck frame with a cab, the cab of the truck became a significant factor in injury causation. In Test #21, the dummy head directly impacted the front left corner of the cab structure, resulting in a very high HIC value.

In some of the tests (e.g., Test # 5), even though the dummy responses were relatively low, the injury potential was significant. As seen in Figure A. 5 in the Appendix, the truck tire can override the car and contact the A-pillar and the roof. The likelihood of severe injuries increases if the dummy head contacts parts of the truck intruding in the car occupant compartment. This was true for impact modes when the contact with the truck tire was minimized (Test # 7) and the truck cab was installed (Test #21).

Lowering the truck front end (non-pivoting designs) resulted in more severe crash pulses on the car and higher dummy reading, although it prevented gross intrusion of the car occupant compartment by the rigid and stiff parts of the truck fronts. None of these concepts, therefore, could be deemed to improve the situation. Managing all the collision energy through absorption did not prove to be feasible, given the constraints for the amounts of energy-absorbing material that could be mounted on the truck front.

A significant finding of the tests was that deflecting the car was a possible approach to managing the impact energy and preventing extensive intrusion into the occupant compartment in some collisions. Test #18 established that the car could be deflected sideways without any significant AV by an appropriate truck front geometry. The practical aspects of having a compact structure that provides an adequate deflection angle without having a large frontal overhang was addressed in EASi's design [3]. The design was analysed with FEM modelling, the results of which were validated by Test #20 and Test

#22. Test # 21 formed the baseline (55 mph baseline truck into 50% offset Taurus) to compare the results of Test # 22 (55 mph truck with EASI's modified front-end into 50% offset Taurus). Further research will examine the possibility of addressing the problem of centerline and minor offset collisions.

Conclusions

1. Deflecting the car by using a swivelling truck front appears to be an effective way to reducing the severity of offset truck-car collisions. This approach also provides for a lower deflecting front with less overhang than normally expected from non-pivoting designs offering similar deflection angles. Such a truck front structure could also result in fewer tripped truck rollovers involving guard-rails, thereby preventing some collisions with other vehicles in opposing traffic lanes, as well as truck occupant fatalities and injuries due to rollovers.
2. Lowering the bumper height of the truck was beneficial in reducing crush and possible compartment intrusion. All of the baseline impacts resulted in significant crush levels to the front of the car, and one resulted in the truck tire intruding into the compartment. The tests with a lowered frontal structure on the truck resulted in solid engagement of the bumper of the car, significantly less crush and no compartment intrusion. Occupant deceleration levels were, however, higher than in the case with no additional front structure.
3. The impact speeds tested (in the range of 40-50 mph) resulted in less damage than anticipated and were lower than in the serious to fatal accident cases reviewed from the NASS study. The initial analysis performed with the CRASH3 model resulted in a selection of 40 mph. This was later revised based upon estimates of energy absorbed by the truck. It may be necessary to test at speeds closer to 65 mph to produce car occupant compartment intrusion levels similar to those noted in some of the more severe accident cases.
4. The injury severities estimated by the dummies in the crash tests were expected to be generally less than those that occurred in the NASS cases. All of the occupants in the accident study were unrestrained. The testing was performed with restrained occupants, because of the current trends in belt use and airbag availability.

HEAVY VEHICLE CRASHES IN URBAN AREAS

Prepared by P. F. Sweatman, Roaduser Research Pty Ltd; K. W. Ogden, Department of Civil Engineering, Monash University; and N. Haworth, B. Corben, G. Rechnitzer, K. Diamantopoulou of Monash University Accident Research Centre

A report prepared for the Federal Office of Road Safety, GPO Box 594, CANBERRA ACT 2601 Report No. CR155 Date Nov. 1995 ISBN 0642512612 ISSN 0810-770X

Abstract

Research into the types, severity and causes of crashes involving heavy vehicles in urban Australia was carried out and countermeasures were recommended to reduce the incidence and severity of such crashes. The project included literature review, mass data analysis, detailed post-crash analysis of fatal crashes, analysis of accident black spots and in-depth investigation. The study found significant deficiencies in driver, rider and pedestrian behaviour which directly relate to the causation of severe crashes. The critical importance of the traffic engineering design of controlled and uncontrolled intersections has been highlighted. The design of heavy vehicles for operation in urban areas also needs improvement and measures to reduce heavy vehicle aggressivity and to redress deficiencies in the driver's field of view are needed.

Executive summary

The Federal Office of Road Safety (FORS) initiated research into the types, severity and causes of crashes involving heavy vehicles in urban Australia. As a result, countermeasures may be developed to reduce the incidence and severity of such crashes.

It is estimated that currently there are approximately one thousand serious heavy vehicle crashes per year in urban areas throughout Australia; the cost of urban casualty crashes involving heavy vehicles is estimated at \$100m per year.

A consortium from Roaduser Research Pty Ltd, Monash University Accident Research Centre (MUARC) and Monash University Civil Engineering was contracted to provide a multi-faceted investigation of the urban heavy vehicle crash issue, how it differs from current knowledge of heavy vehicle safety and potential ways of reducing serious urban crashes involving heavy vehicles. The work of the consortium was coordinated by Roaduser Research.

The project included five tasks, each of which provided a view of urban heavy vehicle safety from a different perspective. The tasks included in the study were:

- Task 1* a review of the literature concerning heavy vehicle safety in urban areas
- Task 2* analyses of available mass data (involving trucks over 3.5t GVW and buses over 5t GVW), covering fatal and injury crashes in urban areas of NSW, Victoria and Queensland and including (i) trends over the period 1984-1993 and (ii) characteristics of crashes occurring during the period 1989- 1993
- Task 3* detailed post-crash analysis of all fatal heavy vehicle crashes occurring in Sydney and Melbourne in the year 1992 (a total of 59 crashes were investigated)

- Task 4* further analysis of existing MUARC in-depth data, where occupant protection issues had been investigated in detail; 29 Victorian crashes, including 14 fatal crashes, were re-investigated (a separate report is available on Task 4)
- Task 5* investigation of heavy vehicle black spot intersections in Sydney and Melbourne for the period 1987-1993; the fifteen intersections showing the highest frequencies of heavy vehicle casualty crashes in each city were investigated (a separate set of reports is available on Task 5)

Overview of Urban Heavy Vehicle Crashes

Fifty to seventy-five percent of all serious rigid truck crashes and twenty-five to fifty percent of serious articulated vehicle crashes occur in urban areas. Furthermore, the severity of articulated truck crashes is markedly higher than the severity of rigid truck crashes in urban areas: about 25% of serious urban articulated crashes were fatal compared to only 11% of rigid truck crashes.

The most common types of crashes were vehicles travelling in the same direction (lower than average severity), vehicles from adjacent directions (at an intersection) and vehicles from opposing directions (more severe than average). Approximately 20% of the crashes were rear-end, most of which were not severe. Cars in rear-end crashes with heavy vehicles were about two to three times more likely to be the struck vehicle than the striking vehicle. Rigid and articulated trucks were more likely to be the striking vehicle, but this pattern was not found for buses. Single-vehicle crashes are in the minority

Drivers are the largest group of persons injured in heavy vehicle crashes and the majority are occupants of the "other vehicle". About a quarter of those injured and about 15% of those killed were occupants of a heavy vehicle. Pedestrians, motorcyclists and bicyclists are the road user groups most likely to be killed in urban heavy vehicle crashes. Bus crashes are more likely to involve a pedestrian and no other vehicle, but most of these are not severe and the crashes comprise mainly passengers falling in or from the vehicle.

Crashes of High Severity

Detailed post-crash analysis was carried out for all fatal heavy vehicle crashes occurring in Sydney and Melbourne in the year 1992. Slightly less than half the crashes occurred at intersections and about two thirds of these intersections were without traffic lights. Most intersection crashes involved the heavy vehicle turning or travelling across the path of the other vehicle. Most of the crashes occurred in residential or residential/commercial areas and occurred in daylight.

Most of the crashes (56%) involved rigid trucks, and a smaller number (29%) involved tractor-semi-trailers; a relatively small percentage of all crashes (24%) involved long-haul vehicles. Most crashes involved smaller delivery trucks

In most cases, the "other vehicle" was a car, although pedestrians were relatively frequently involved. In the majority of cases (64%) the "other vehicle" was solely responsible for the crash, and was solely or partially responsible in a total of 77% of cases. The heavy vehicle was solely responsible in 15% of cases and was solely or partially responsible in a total of 33% of cases; joint responsibility was assigned in 11% of cases. This agrees reasonably well with the finding in the literature review that the heavy vehicle was responsible in approximately 20% of multi-vehicle crashes.

Factors in Fatal Crashes

It was found that, in many cases, a large number of factors relating to drivers, roads, traffic, vehicles or environment contributed to the causation and consequences of fatal urban heavy vehicle crashes. These were classified as (i) precipitating factors without which the crash probably would not have happened and (ii) contributory factors.

The most frequent *precipitating factors involved in causing crashes* in Sydney and Melbourne were found to be:

- inappropriate behaviour by pedestrians (15%)
- excess speed by car drivers and motorcycle riders (11%)
- inattention on the part of car drivers and motorcycle riders (11%)
- disregard of traffic controls by heavy vehicle driver (9%)
- disregard of traffic controls by car drivers and motorcycle riders (9%)
- disregard of traffic controls by pedestrians (9%)
- alcohol or drug use by car drivers and motorcycle riders (9%)
- limited heavy vehicle field of view at the front passenger side (7%).

The most frequent *factors contributing to crash occurrence* in Sydney and Melbourne were found to be:

- road geometric standards providing insufficient separation between traffic streams (36%)
- truck driver inattention (22%)
- car driver and motorcycle rider inattention (22%)
- inappropriate behaviour on the part of pedestrians and cyclists (22%)
- attitudinal problems on the part of car drivers and motorcycle riders (16%)
- excess speed of cars and motorcycles (15%)
- roadside objects (15%)
- road alignment (15%).

The most frequent *factors contributing to injury severity* in Sydney and Melbourne were found to be:

- lack of side under-run protection on heavy vehicles (11%)
- unguarded wheel areas of heavy vehicles (11%)
- structural stiffness of the rear of the heavy vehicle (7%)

- lack of rear under-run protection (5%)
- structural stiffness of the side of the heavy vehicle (4%)
- structural stiffness of the front of the heavy vehicle (4%)
- front under-run protection (4 %).

Countermeasures

In order to *reduce the occurrence of fatal urban heavy vehicle crashes*, the study recommends:

- (i) better design of urban road environments, to assist drivers of heavy vehicles, drivers of other vehicles and pedestrians in avoiding crashes; the most critical areas are pedestrian facilities, the design of uncontrolled intersections and of signal controls, the provision of full medians on urban arterials, the provision of adequate road space, more adequate geometric design of intersections, especially for turning heavy vehicles, and the provision of adequate sight distance and delineation
- (ii) better heavy vehicle design, performance and configuration: key areas are driver's field of view, the right balance between vehicle productivity, size and turning performance and improvements in braking and stability (to reduce crash risks and to contribute to improved driver behaviour)
- (iii) improved behaviour and signal obedience of heavy vehicle drivers at controlled intersections - including through-travel and turning situations - and greater attention to other drivers' and pedestrians' actions
- (iv) improved behaviour and performance of the drivers of light passenger vehicles: key areas are lower speeds, signal obedience in turning as well as through-travel, commitment to responsible and legal driving practices and greater attention to other drivers' actions
- (v) improved commitment to responsible and legal riding practices, including non-excessive speeds, by motorcycle riders
- (vi) modified behaviour of elderly and juvenile pedestrians, in terms of improved judgement and adherence to crossing signals at intersections
- (vii) changes in the emphasis of urban road and traffic management and enforcement to better recognise the truck-related hazards related to: pedestrian crossings at intersections (especially for elderly and juvenile pedestrians), excessive motorcycle and car speeds and poor adherence to intersection controls for both straight-through and turning heavy vehicles, cars and motorcycles.

In order to *reduce the injury severity resulting from urban heavy vehicle crashes*, the study recommends:

- (i) improved design of heavy vehicles: key areas are reduced frontal, side and rear aggressivity, the use of side guards and wheel guards to deflect pedestrians and bicyclists and improved cabin crashworthiness; the results of Tasks 3 and 4 of this study are in agreement that side protection would be approximately twice as

effective as front or rear protection with regard to reducing urban heavy vehicle fatalities

- (i) improved design of light passenger vehicles with respect to occupant protection in frontal impacts with the frontal, side and rear structures of heavy vehicles and in side impacts.

Measures to reduce heavy vehicle aggressivity and to improve field of view from the cabin stand out as clear and feasible countermeasure options with very significant urban heavy vehicle safety potential. Specifications for front, side and rear-underline devices are available and a total heavy vehicle protection package could reduce urban heavy vehicle fatalities by almost 10%. Improved field of view by either improved cabin design or the use of effective add-on devices could reduce urban heavy vehicle fatalities by up to 7%.

Strategies

The causation of urban heavy vehicle crashes is highly interactive between the driver, vehicle and road environment elements of the traffic system and significant improvements will require changes in all of these areas. The recommended design improvements in the road environment and vehicles - especially heavy vehicles - would not only have benefits in their own right but would assist drivers, riders and pedestrians to perform and behave in a more appropriate manner.

The study has brought to light significant deficiencies in driver, rider and pedestrian behaviour which directly relate to the causation of severe crashes. These deficiencies apply to the heavy vehicle driver, but no more so than to the other human players. The critical importance of the traffic engineering design of controlled and uncontrolled intersections has been highlighted and provisions for the interaction of heavy vehicles and other road users at intersections on routes heavily used by trucks is generally inadequate. It has been shown that the effective control of turning movements is just as important as the control of through movements. The design of heavy vehicles for operation in urban areas also needs improvement and measures to reduce heavy vehicle aggressivity and to redress deficiencies in the driver's field of view are needed.

The findings of the study have shown that current road management safety strategies are generally appropriate and well-targeted in their scope. The study has also shown that the following strategic areas should receive highest priority:

- improving the safety performance of heavy vehicle drivers
- reducing the aggressivity of heavy vehicles in collisions with lighter vehicles
- improving the stability and control of heavy vehicles
- the introduction of appropriate developments in intelligent transportation systems (ITS).

The study has also shown that strategic initiatives are also needed in the areas of:

- improving the safety performance of pedestrians, drivers of light passenger vehicles and motorcyclists, in relation to their interaction with heavy vehicles

- improving the safety performance of controlled and uncontrolled intersections.

With regard to the efficiency of freight vehicle operations in urban areas, the study has shown that a great deal of care is needed in designing safe heavy vehicle routes. Such routes are needed for the non-hazardous urban transit of the larger heavy vehicle configurations. The efficiency of the smaller heavy vehicles which should be used for urban deliveries is a more complex matter because the study has shown heavy vehicle size to be a factor in serious urban crashes. Research is needed to develop the appropriate balance between the use of larger and smaller heavy vehicles in urban areas in order to meet both safety and efficiency objectives.

DESIGN PRINCIPLES FOR UNDERRIDE GUARDS AND CRASH TEST RESULTS

George Rechnitzer, Senior Research Fellow, Monash University Accident Research Centre, Clayton, Vic., Australia.

Abstract

The presentation included:

- a review of design principles, theory and design criteria for effective underride protection and the design of energy absorbing systems for the rear and front of heavy vehicles;
- the results and findings from the crash test program for rigid and energy absorbing rear underride barriers;
- a brief review of current regulations, their limitations, particularly regarding underride protection in the context of findings from crash investigations, theory and crash test results.

Design principles for injury mitigation

In considering countermeasure options for reducing the harm potential in crashes involving heavy vehicles and other road users, certain design concepts need to be kept in mind to ensure the effectiveness of any proposals. These are primarily:

- Reduce the exchange of energy between impacting vehicles
- Provide energy absorption to reduce forces and accelerations on vehicles, vehicle occupants and unprotected road users
- Ensure compatibility (stiffness and geometric) between interacting structures, be they vehicles or humans.

It is the *exchange* of energy that needs to be managed, not the kinetic energy of the heavy vehicle.

FEDERAL MOTOR VEHICLE SAFETY STANDARDS REQUIREMENTS FOR REAR UNDERRIDE PROTECTION

A presentation to the SAE Heavy Vehicle Underride Protection TOPTEC Palm Springs April 15-16 1997. George E Mouchahoir, Safety Engineer, US Department of Transportation, NHTSA

In 1996 two new Federal Motor Vehicle Safety Standards (FMVSS) were introduced to require manufacturers of trailers and semi-trailers to provide a guard at the rear end of the truck to provide protection to vehicles that may underride the truck.

There were 380 rear end fatalities per year 54 of which included passenger compartment intrusion. In addition there were 5131 non-fatal injuries. About 80% of fatalities involve trailers and semi-trailers.

1992 NHTSA proposal was for a 100 mm cross-sectional guard not more than 560 mm above the ground with defined strength and deformation limits at three points.

Safety advocates requested a 400-450 mm maximum ground clearance and the inclusion of single unit trucks.

Research showed guard height adequate to prevent underride, there were no safety benefits for lowering the ground clearance height, costs would increase by 20% at lower height, air bag deployment was not affected.

The final rule had the dimensional requirements shown below.

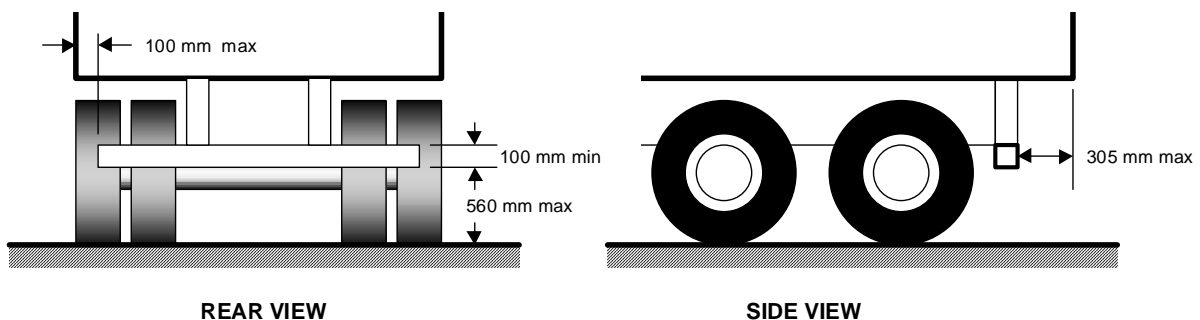

Strength requirements are that the following forces applied 50 mm above the bottom of the guard must be resisted without deflecting the guard more than 125 mm:

- 50 kN applied to a point measured $3/8^{\text{th}}$ of the barrier length from the centre line of the barrier;
- 50 kN applied to the centre line of the barrier;
- 100 kN applied to a point measured 355 – 635 mm from the centre line of the barrier, with a requirement that at this point at least 5650 J of energy is absorbed in the first 125 mm of deflection.

UNDERRIDE GUARDS: IS THE NEW NHTSA REGULATION GOOD ENOUGH?

A presentation to the SAE Heavy Vehicle Underride Protection TOPTEC Palm Springs April 15-16 1997. Byron Bloch, Consultant, Auto Safety Design

In final Regulatory Analysis NHTSA noted that over 13 years car into truck rear end fatalities averaged 421 per year with 73% into trailers and semi-trailers and 27% into trucks with a GVM of at least 4537 kg (10000 lb).

Testing prior to the Regulatory research had been at 55- 65 km/h whereas this testing was at 48 km/h. Further there was no regard given to injury crashes.

A 1977 study by the Highway Safety Research Institute showed the following distribution of impacts in fatal car into truck crashes:

Combination vehicles:

Passenger side:

- Side on into steer axle – 3 cases
- Side into centre of prime mover – one case
- Side into drive axle – one case
- Side into trailer draw bar – one case
- Side into front half of trailer – 2 cases
- Side into centre of trailer/semi-trailer – 13 cases
- Side wipe into front of rear trailer axle group – 2 cases

Rear

- Rear under passenger side corner – 9 cases
- Rear into rear of trailer – 40 cases
- Rear under driver side corner – 18 cases

Driver side:

- Side on into steer axle – 1 case
- Side into drive axle – 2 cases
- Side into trailer draw bar – one case
- Side into centre of trailer/semi-trailer – 24 cases
- Side wipe into front of rear trailer axle group – 14 cases
- Side into rear axle trailer group – 2 cases

Rigid trucks:

Passenger side:

- Side on into steer axle – one case
- Side into centre of truck – 5 cases
- Side into drive axle – 2 cases

Rear

- Rear under passenger side corner – 5 cases
- Rear into rear of trailer – 12 cases

Rear under driver side corner – 10 cases

Driver side:

Side on into steer axle –1 case

Side into centre of truck – 7 cases

Side into drive axle – 4 cases

Of 87 cases 65 cases were in the 48 km/h to 80 km/h range.

Truck Underride Studies

Cornell 1970 – Tests of 457 mm and 604 mm. Recommended 457 mm height and to withstand 270 kN force for 64 km/h protection

IIHS –1977 - Tests of 533 mm and 711 mm. Recommended 533 mm height for 64 km/h protection.

Dynamic Science, 1980 - Tests of 508 mm, 559 mm and 604 mm. Recommended 508 mm height for 64 km/h protection.

COMPARISON OF INCIDENCE OF LARGE TRUCK – PASSENGER VEHICLE UNDERRIDE CRASHES IN THE FATAL ACCIDENT REPORTING SYSTEM AND THE NATIONAL ACCIDENT SAMPLING SYSTEM AND A PHOTOGRAPH-BASED STUDY

A presentation to the SAE Heavy Vehicle Underride Protection TOPTEC Palm Springs April 15-16 1997. Elisa R Braver from Insurance Institute for Highway Safety

Based on two papers with similar titles by Elisa R Braver, Michael X Cammira, Adrian K Lund, Nancy Early, Michael R Powell from Insurance Institute for Highway Safety and Eric L Mitter Transportation Research Center Indiana University.

Studies attempted to resolve differences in reported levels of underride. In the 1988-1993 period Fatal Accident Reporting System (FARS) reported 4% of all fatal large truck – passenger car crashes involve underride. The National Accident Sampling System (NASS) in contrast reported 27% of 275 crashes. Of these 275 crashes 7% were also recorded as underride in FARS. But NASS does not code side underrides. Adding side underrides increased the NASS figure to 50%. Using NASS data it was estimated that there were:

- 1108 fatal crashes per year (95% confidence limits 735 – 1482)
- 634 involved the front of trucks (CI 328-942)
- 248 involved the rear of trucks (CI 137-360)
- 226 involved the side of trucks (CI 110-341)

Detailed analysis of the 275 crashes showed the following:

Truck impact location	Passenger vehicle impact location	Coded as underride in FARS or NASS	Not coded as underride in FARS or NASS	Percent underride
Front	Front	19	31	38%
	Rear	12	9	57%
	Side	3	77	4%
Side	Front	6	28	18%
	Rear	0	2	0%
	Side	1	12	8%
Rear	Front	43	27	61%
	Rear	0	1	0%
	Side	0	0	0%
Unknown			4	
TOTALS		84	191	44%

Numbers of the estimated 1108 fatalities involving various locations and vehicle types were:

Location	Prime mover bobtail	Combination vehicles	Rigid trucks	Unknown	Total
Front	48	426	151	10	634
Side	5	179	41	0	226
Rear	0	185	69	14	248
Total	53	770	261	24	1108
Percent	5%	69%	24%	2%	1108

A further photographic study was undertaken. For the 107 fatal underride crashes in Indiana in 1993, photographs were obtained for 98. The FARS database showed the incidence of underride as 6%. Inspection of the photographs showed underride was a factor in 63% of cases. Further work estimated that preventing underride would have substantially reduced the likelihood of death or serious injury in about 20% of these crashes.

HEAVY TRUCK UNDERRIDE RISK ANALYSIS

A presentation to the SAE Heavy Vehicle Underride Protection TOPTEC Palm Springs April 15-16 1997. Edmund Lau, Managing Scientist, Failure Analysis Associates

The study related to Class 7 and Class 8 heavy trucks with trailers and used the FARS database as the data source. It was estimated there were 20-30 rear end underride fatal crashes per year. Trends from 1975 – 1993 were examined.

On average there were about 90000 occupants of about 55000 vehicles involved in about 35000 fatal crashes. Heavy trucks were involved in about 4200 crashes.

For the 19 years from 1975 – 1993 there were:

- 77,560 occupants in crashes involving heavy trucks;
- 67,115 occupants in collisions involving heavy trucks;
- 8,046 occupants in rear end collisions involving heavy trucks;
- 6,557 occupants in rear end collisions involving combination heavy trucks;
- 505 occupants in rear end **underride** collisions involving combination heavy trucks **from 1978 –1993**.

UNDERRIDE COLLISIONS – A CANADIAN PERSPECTIVE

A presentation to the SAE Heavy Vehicle Underride Protection TOPTEC Palm Springs April 15-16 1997. E R Welbourne and D Boucher, Transport Canada

Five years of data from 1989 – 1993 were examined. There was insufficient data or other data problems that prevented an accurate estimate of national figures for underride crashes.

Reference was made to the need for trailers to be able to negotiate a 15 degree exit ramp.

In Canada the maximum permitted rear overhang **measured from the rearmost axle** is 3.775 m. A fixed guard allows a maximum exit angle of 8.4 degrees (there is no explanation of how such trailers would negotiate the same slopes as mid-axle groups).

EEVC WORKING GROUP 14 ACTIVITIES IN ENERGY-ABSORBING FRONT UNDERRUN PROTECTION

A presentation to the SAE Heavy Vehicle Underride Protection TOPTEC Palm Springs April 15-16 1997. Peter J A de Coo, Scientific Research Associate, TNO) Road-Vehicles Research Institute, Crash Safety research Centre

Typical crash parameters were developed from European data – namely:

- relative speed 75 km/h
- overlap 75%
- collision angle 0 degrees
- truck mass \geq 12 tonnes
- car mass 800-1,100 kg
- two occupants in the front seat.

European manufacturers supplied data that showed the space available for energy absorption varied between 160 mm and 480 mm with an average of 360 mm.

In tests the ground clearance was 350 mm. An impact speed of 56 km/h was used. The results from testing were then extrapolated out to cover 75 km/h relative speeds.

Consideration was given to rigid Front Underrun Protection Devices (FUPD) and energy absorbing Front Underrun Protection Devices (FUPD) Testing suggested that the energy absorbing devices should start to deform at about 200 kN and exhibit reasonable maximum forces of 400 – 600 kN. A deformation of 360 mm was found to be optimal (The report does not explain why 480 mm was found to be worse).

If rigid Front Underrun Protection Devices (FUPD) were fitted the reduction in fatalities per year would be about 21%. The percentage increases slightly (about 0.5%) if 50 mm deflection is assumed.

If energy absorbing Front Underrun Protection Devices (ea FUPD) were fitted with a deflection of 360 mm the reduction in fatalities per year would be about 30%.

Cost benefit analysis suggested that at a cost of up to 1500 ECU energy absorbing FUDP's would be economic.

HEAVY VEHICLE FRONTAL AGGRESSIVENESS: CRASH TEST RESULTS WITH COUNTERMEASURE CONCEPTS.

A presentation to the SAE Heavy Vehicle Underride Protection TOPTEC Palm Springs April 15-16 1997. Alok K Prasad, supervisor, research Scientist, Transportation Research Center, Vehicle research and Test Center, US Department of Transportation

About 3800/4000 passenger and light truck occupants killed and 63,000/100,000 injured in collisions with heavy vehicles. Of these collisions 70% involve the front of the heavy truck.

Heavy truck aggressiveness relates to the large mass differential, the geometric mismatch and the stiffness mismatch.

In the study of crashes in the years 1981-1987, cars and light vehicles up to 4540 kg GVM were considered and heavy vehicles of 11800 kg GVM or more. Truck impact directions of 11 o'clock to 1 o'clock were considered

For cases with serious injuries 45% involved the car front, and 55% would be addressable by changing the truck front. Delta V for crashes was 90 km/h or less for 80% of cases.

For testing a bumper height of 215 mm was used, with 610 mm of honeycomb padding and a simple 30 degree deflection angle outside the truck chassis lines.

Results showed that vehicles were not deflected so a compound angle barrier was devised – 50 degree sweep-back and 45 degree tilt back with no padding to promote sliding, and a swivelling front plate.

Tests showed that designs did not reliably lower occupant acceleration responses. Injuries were generally caused by the crash pulse. Swivelling and/or curved fronts may result in injuries due to compartment intrusion because of offset and/or concentrated loads.

PERFORMANCE CRITERIA, DESIGN AND CRASH TESTS OF EFFECTIVE REAR UNDERRIDE BARRIERS FOR HEAVY VEHICLES

George Rechnitzer, Chris Powell and Keith Seyer. Paper 218 (2001)

During the 1990's research undertaken at Monash University and studies in Europe, USA and Brazil have led to recommendations about the performance criteria for rear underrun barriers for heavy vehicles over 3.5 tonne.

Testing in the Monash research showed that in tests at 50 km/h and a light vehicle weight of 1420 kg the peak forces on a rigid barrier were around 300 kN for both centred and offset crashes. For centred tests the vehicle crush was about 0.5 m.

Tests of an energy absorbing barrier with a 1800 kg light vehicle at 48 km/h and 400 mm stroke barrier travel showed peak decelerations were halved and crash pulse durations doubled. Further tests with Hybrid 3 ATDs showed considerable improvement over the ADR 69 Barrier test results for head injury and maximum femur compressive load.

Finally a test with a redesigned energy absorbing barrier and a 1350 kg car at 75 km/h with a 300 mm stroke barrier showed that Hybrid 3 results were close to those for a 56 km/h barrier test. Peak loads on the struts were around 350 kN.

Other studies have shown peak loads of 356 kN to 445 kN (Moffat and Wong 1980) and 680 kN (Deleys and Ryder 1971). These however have a very short duration so that barriers designed to lower static loads perform satisfactorily in these situations.

As a result of these tests and other studies

Load position	E.C.E R58 : Rear barrier **	USA FMVSS 223/224 Rear	Brazil Rear barrier	Recommended from this study
outer edge P1	25 kN	50 kN	100 kN	200 kN
centre P3	25	50	100	100
off centre P2	100	100	150	200
Allowed deflection		125 mm		
Energy absorption		125 mm		50 kJ
Height	550	560	550	400

DEFLECTION OF CARS AWAY FROM THE FRONT OF TRUCKS IN OFFSET HEAD ON CRASHES

One proposal has been to design the front of trucks so that they will direct light vehicles away from the front and so reduce the levels of deceleration imposed on the light vehicle occupants.

This has been analysed from a theoretical point of view. It is assumed that the bumper bar is angled back from close to the outside of the chassis rails as shown below.

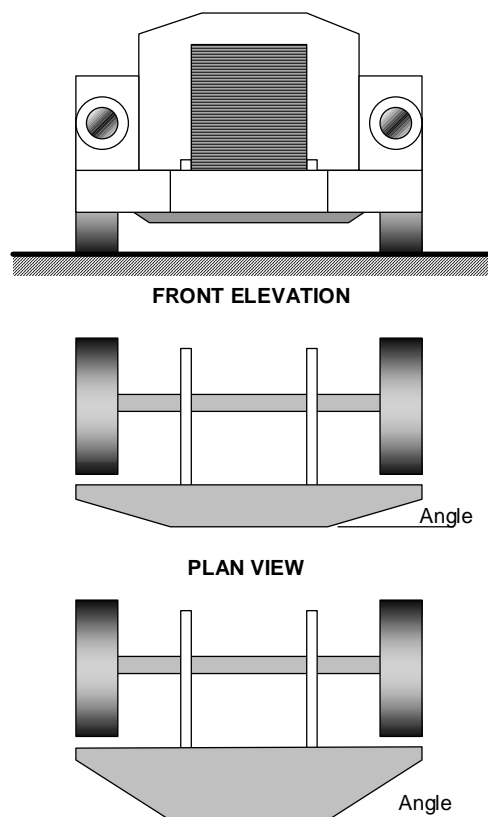

The analysis considered a range of vehicle overlaps from 10% to 40% being equivalent to the car overlap extending the minimum to extending to the chassis rails.

Analysis included data for a typical friction factor of 0.4 and for a low friction factor of 0.2. The results are shown in the graphs below.

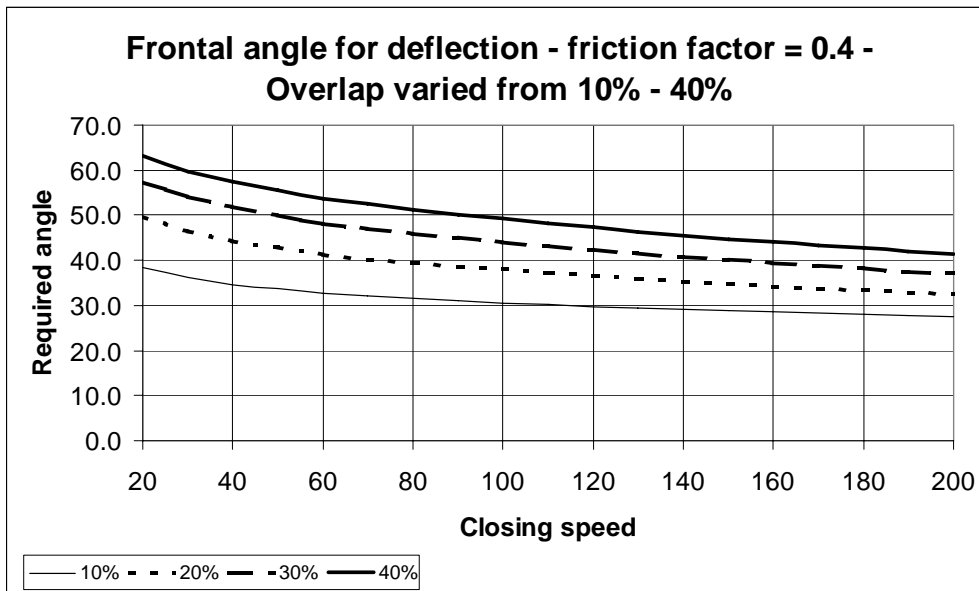

For the usual friction factor of around 0.4, and assuming an overlap of 40% or around 720 mm, for common closing speeds of 30 km/h to 80 km/h angles of up to 60 degrees are required.

An angle of 60 degrees would require the distance from the front bumper to the steer axle to be about 1950 mm which is 500 mm or more greater than the larger front overhang rigid trucks and prime movers.

At this angle, with a full frontal crash, there would be a tendency for a significant increase in light vehicle deformation. A rough approximation suggests an increased deformation of around 100 mm to the centre of the light vehicle.

It should be noted that the decrease in required angle for deflection with speed reflects the extra deformation of the car body which provides for more “time” for the vehicle to be accelerated sideways.

To check if a lower friction factor would assist, a value of 0.2 was modelled.

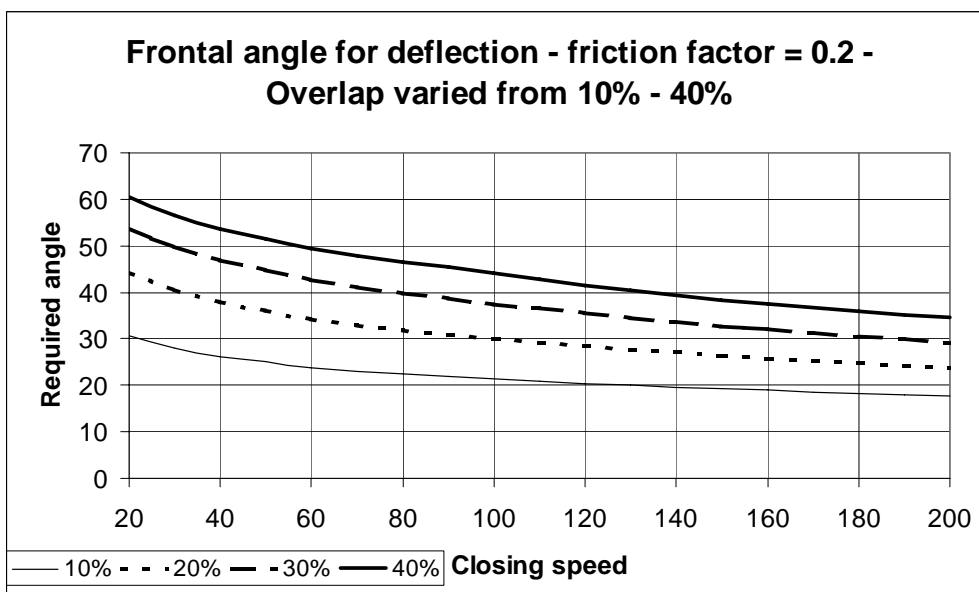

As can be seen, there is little decrease in the angles required to ensure the vehicle is deflected. This is because considerable energy is required to accelerate the vehicle sideways.

Note also that sideways accelerations required at the larger overlaps are considerable at the higher speeds. At 80 km/h accelerations of 10-12 g are required to deflect the vehicle at a 40% overlap. These are combined with forward decelerations of 18 – 27 g in the forward direction. Given these are average values the peaks will be much higher and will be life threatening.

A further consideration is that the deflected vehicle will have had its steering compromised and the driver is unlikely to be in a position to control the vehicle for this reason and the effects of the forces applied to them. Hence there would be considerable potential for further collisions between the deflected vehicle and other vehicles or objects.

Based on the above it is considered that side deflection mechanisms are unlikely to have a significant impact on reducing trauma in head on light vehicle to heavy vehicle crashes.

Hence the preferred mechanism for reducing trauma would be to provide energy absorbing functionality combined with sufficient thickness to reduce overall decelerations experienced by the light vehicle occupants.

APPENDIX D

CURRENT TRUCK DESIGNS AND THE POTENTIAL FOR FRONT UNDERRUN

Current prime mover and truck designs have been reviewed in regard to front underrun.

Some manufacturers have made a point of redesigning the front of their prime-movers to ensure full engagement of the truck bumper bar with car bumper bars in head on situations. For example Scania which has publicised the fact on its Internet site.

Being mindful that even small trucks present a considerable risk to light vehicles the review covered designs from around 3.0 tonnes GVM upwards.

The photos and diagrams below illustrate a range of designs.

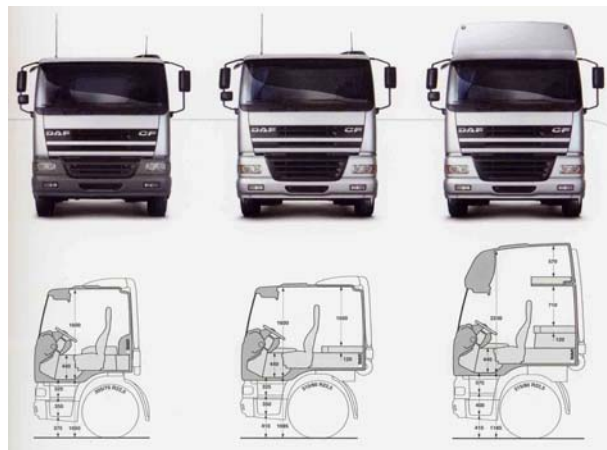

These DAF designs have front bumpers whose lower edge is at 375-410 mm above the ground.



Most smaller trucks have fairly low front bumper bars so that while some underrun may occur it will be limited – see the photograph above.



However there is a range of rigid trucks of a larger size which are poorly designed from a frontal underrun point of view. These are of the style shown above. Not only do these designs represent an increased risk to the occupants of light vehicles, they also are of a design that puts the steering axle at high risk of damage and hence a high risk that the steering will be compromised.



Within the one make there can be some variation in frontal design and frontal underrun clearance as shown in the photograph above of a line-up of Volvo prime-movers..

Additional concern

In observing the vehicle fleet in respect of rear underrun, it was noted that there were a number of four wheel drive style vehicles with high front clearances.

Given these vehicles weigh more than a typical sedan consideration may be needed as to what should be done to make them fit other light vehicles more effectively.

APPENDIX E

CURRENT TRUCK DESIGNS AND THE POTENTIAL FOR SIDE UNDERRUN

Current prime mover, truck and trailer designs were reviewed in regard to side underrun.

The situation is similar to that applying to front underrun as shown in the photographs below.



Dimensions: 4x2 1223 L/54

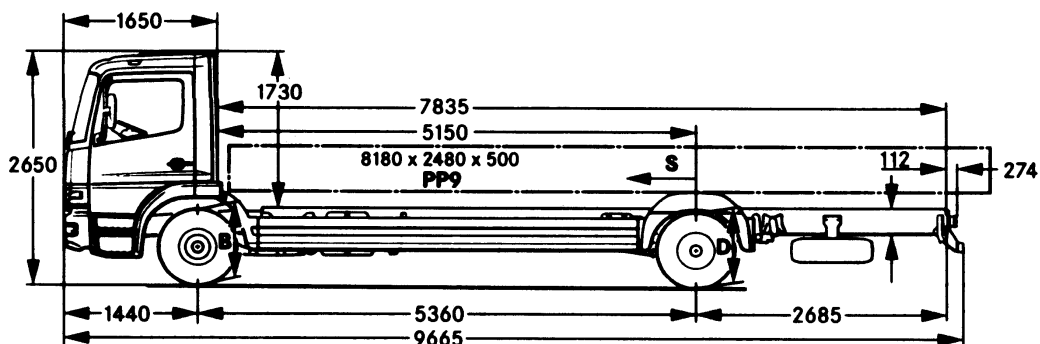

Mercedes Benz now supplies side underrun protection as standard on its rigid trucks although such protection will not necessarily include the area of the rear overhang projection.



In Europe side underrun protection is mandated as shown above. However once again there may be some limits to the degree of protection provided as shown above. (Note also that the rear underrun protection may be limited for this design).



Some vehicles by their design provide considerable side underrun protection as shown for the car carrier above. Note that while there is considerable rear projection with this design the underrun clearances are generally low.



The van above has been fitted out with bins and other functional items that give full underrun protection.



Some Australian trailer manufacturers are moving incorporate side underrun protection as shown in the photograph above. Note however that with no Australian standard such barriers may be less than optimal. Arguably the underrun clearance of the barriers above is too high.



Krone, a European trailer manufacturer has run publicised testing of trailer side underrun – this included presenting the information on a current affairs show.



The removals van above has been fitted with panels that would serve as underrun protection though the money was principally spent to provide a truck which would be eye catching as a means of marketing the business. Note the truck front underrun clearance is high.

APPENDIX F

CURRENT TRUCK & TRAILER DESIGNS AND THE POTENTIAL FOR REAR UNDERRUN

The problem of rear underrun is amply shown on the photograph below.



While this was a low speed crash the A pillar of the car is in contact with the rear of the truck while the front of the car has just contacted the truck wheels. Hence the crashworthiness of the car has not come into play even at the point of cabin intrusion.

The current design standard for underrun barriers requires that semi-trailer be fitted where the wheels are not at the back of the trailer. Rigid trucks do not require rear underrun barriers.

In developing that standard arguments were put that the rear underrun could not extend to the full width of the trailer because it would catch on posts and similar objects during turning manoeuvres. The likelihood of such problems would be much greater for rigid trucks.

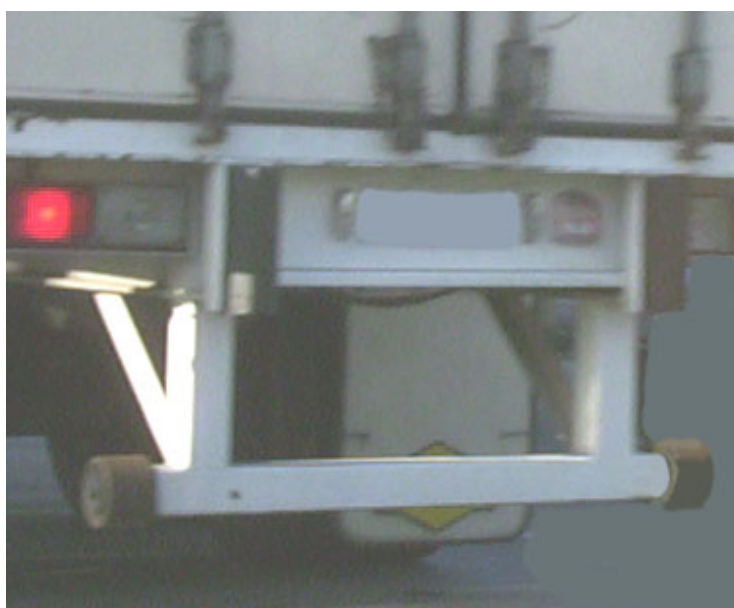

In spite of the current requirements there are a large number of semi-trailers that appear to be fitted with non-conforming underrun barriers. An example is shown above.

In contrast there are many rigid trucks with overhangs of 1.5 metres or greater with full width rear underrun structures at clearances of around 0.4 metres. The existence of these vehicles suggests that the claimed need for rear underrun to not be full width and be higher than 400 mm may be subject to questioning. The evidence suggests there is no real case for either requirement.

Additional concern

In observing the vehicle fleet in respect of rear underrun, it was noted that there were a range of four wheel drive style vehicles with high rear underrun clearances. See the photograph below:



Given these vehicle weigh more than a typical sedan consideration may be needed as to what should be done to make them fit other light vehicles more effectively

APPENDIX G

UNDERRUN AND GROUND CLEARANCE ON NEW VEHICLES

Australian Design Rule (ADR) 43/04 provisions on ground clearance require the following:

6.4 'Ground Clearance' *The 'Ground Clearance' of a vehicle, other than an L-Group vehicle, measured from a horizontal road surface to any point on the underside of the vehicle except the tyres, wheels and wheel hubs must, under the conditions of 'Maximum Loaded Test Mass' loading as specified in the relevant braking rule, be not less than:*

6.4.1 *for any point in the width of the vehicle which is within one metre fore and aft of any 'Axle', 100 mm;*

6.4.2 *for the mid-point between any 2 consecutive 'Axles', the dimension in millimetres obtained by multiplying the distance between those 2 'Axles' in metres by 33.33; and*

6.4.3 *for any other point, 'Ground Clearance' is such that if the wheels of one 'Axle' are on one plane and the wheels on the next consecutive 'Axle' are on another plane which intersects the first so that the angle between them is 7 degrees 38 minutes the point will pass over the apex transverse to the vehicle formed by that intersection, as shown in Figure 1.*

The simple view of this situation is that shown below:

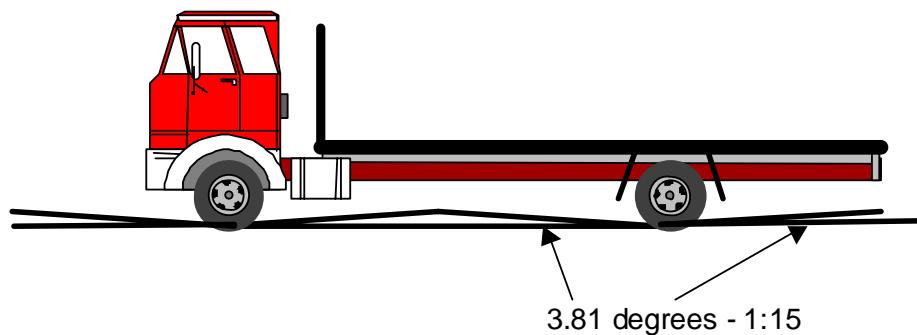

Clearance is defined fore and aft of the outermost axle in each axle group by a sloping line at 3.81 degrees. Technically this is the limit required of heavy vehicles.

However it also allows for instances where the vehicle negotiates a dip as shown below

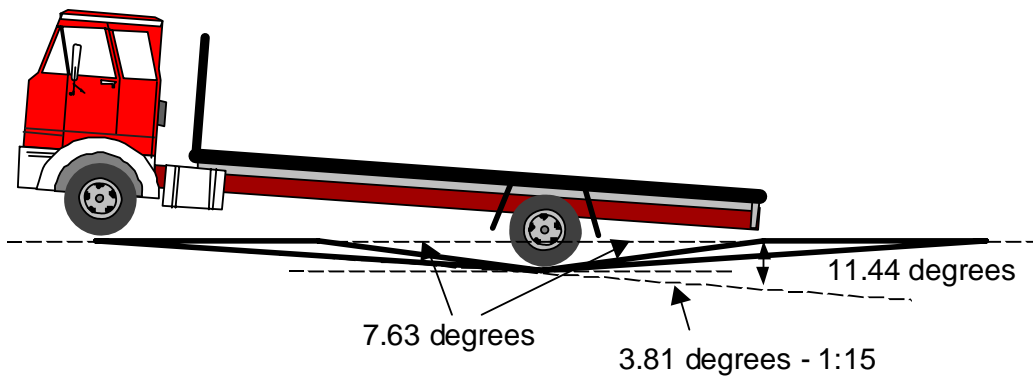

Analysing ADR 43/04 requirements shows that to ensure clearance of any underrun barrier in the situation above, the barrier must be at or above a line sloping upwards from the last axle of 11.44 degrees.

The graph below shows minimum rear underrun clearances for the situation envisaged in ADR 43/04, and for other angles two and three times the 3.81 degree specified by that Rule.

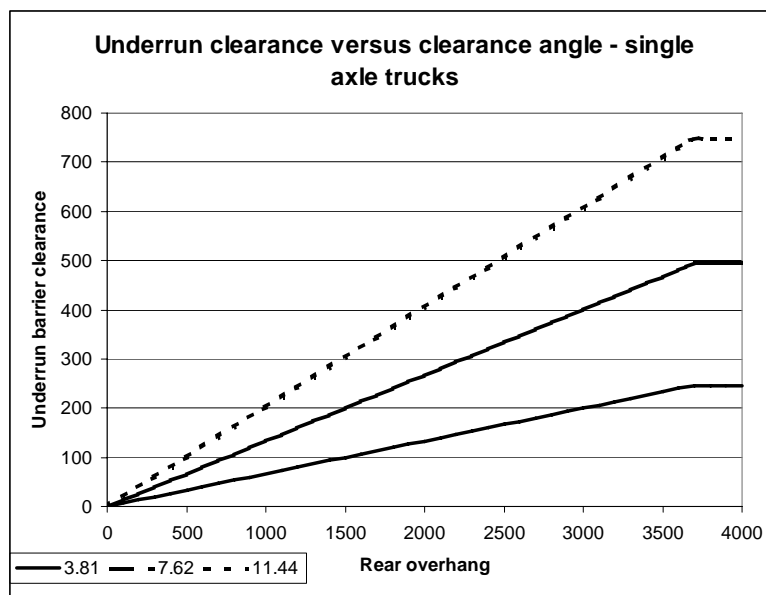

Other considerations

To ensure good braking balance and handling, and/or appropriate loading on each axle, vehicle bodies should be designed so that water-level loading achieves:

- either axle groups evenly loaded in relation to their mechanical capacity,
- or axle groups loaded to axle mass limits, with axle mass limits as the maximum limit on any axle group.

Information on new vehicles was obtained from dealers. This was then used to estimate the rear overhang required to give mass limits on each axle or axle group when the vehicle was uniformly loaded. The results are shown in the graph below.

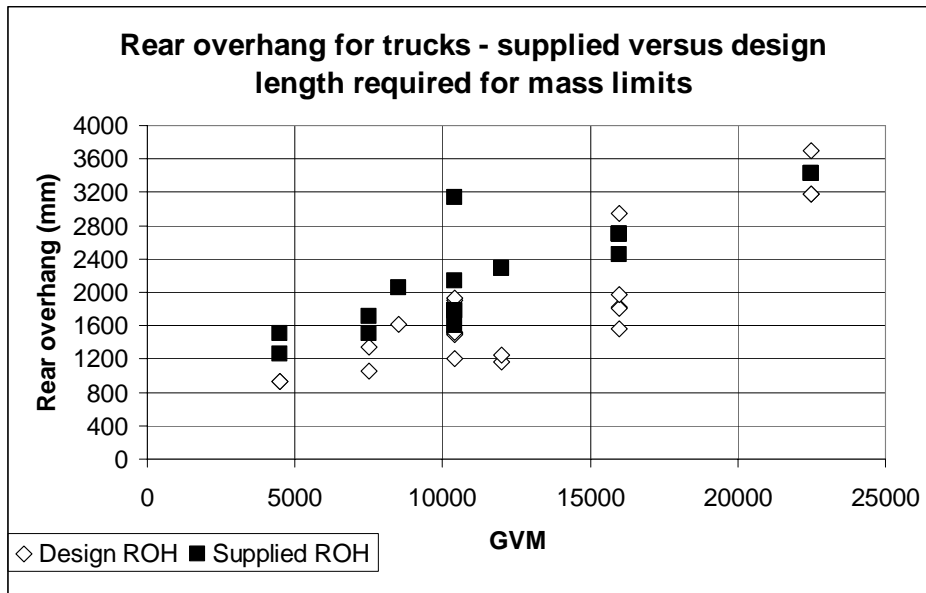

As can be seen many vehicles are supplied with actual rear overhangs exceeding the design rear overhang for uniform loading.

Discussions with dealers revealed that this was due to the vehicle owners wanting a highly manoeuvrable vehicle (hence short wheel base) with a maximum vehicle volume capacity. This is contrary to Vehicle Standards Bulletin 6

Further analysis showed the potential rear underrun (distance between back of truck at design length to the rear of the rearmost tyres) and the minimum rear underrun clearance at twice the angle specified in ADR 43/04. The results are shown below:

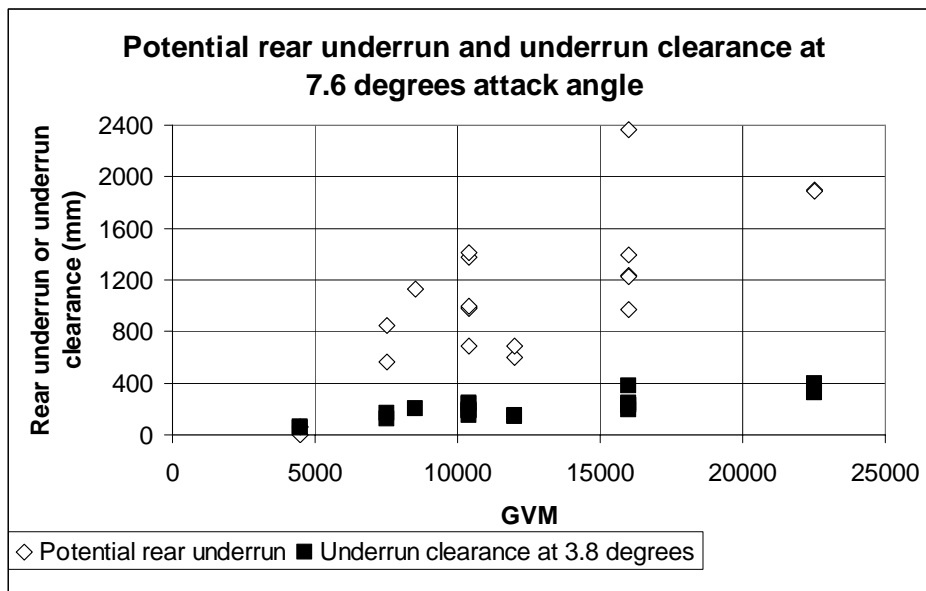

Based on this analysis rear underrun clearances as low as 400 mm are supportable.

HEAVY VEHICLE SAFETY STANDARDS ON UNDERRUN

REAR UNDERRUN PROTECTION

ECE Regulation No 58 – Rear Underrun Protection

The dimensional requirements are:

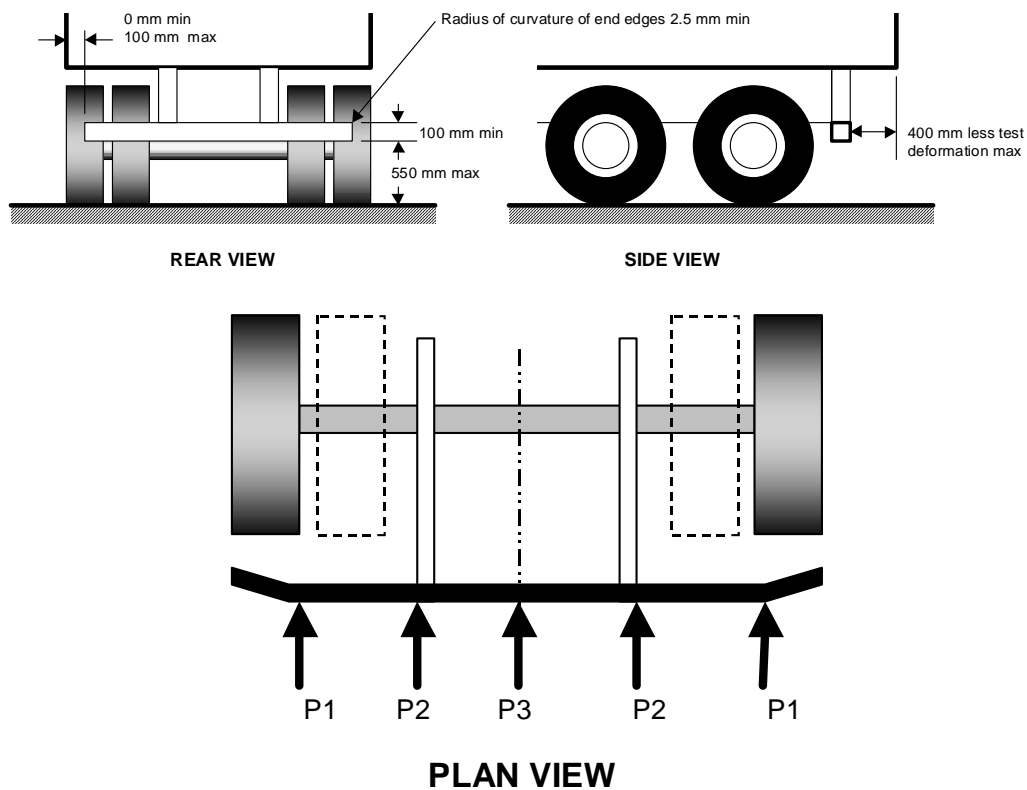

Strength requirements are that the following forces applied at the centreline of the device:

- 25 kN or a force equal to 12.5% of the maximum mass of the vehicle, whichever is the lesser, applied consecutively to two symmetrical points located 300 mm +/- 25 mm from the longitudinal planes tangential to the outer edges of the rear axles (points P1 above), and a third point located in the median vertical plane of the vehicle (point P3 above);
- 100 kN or a force equal to 50% of the maximum mass of the vehicle, whichever is the lesser, applied to two points situated symmetrically about the centreline of the device or the vehicle (points P2 above). These two points shall be .700 mm to 1000 mm apart.

USA Federal Motor Vehicle Safety Standard 223 – Rear Impact Guards (test requirements) and Federal Motor Vehicle Safety Standard 224

The requirements of these rules may be summarised as stated below.

The dimensional requirements are:

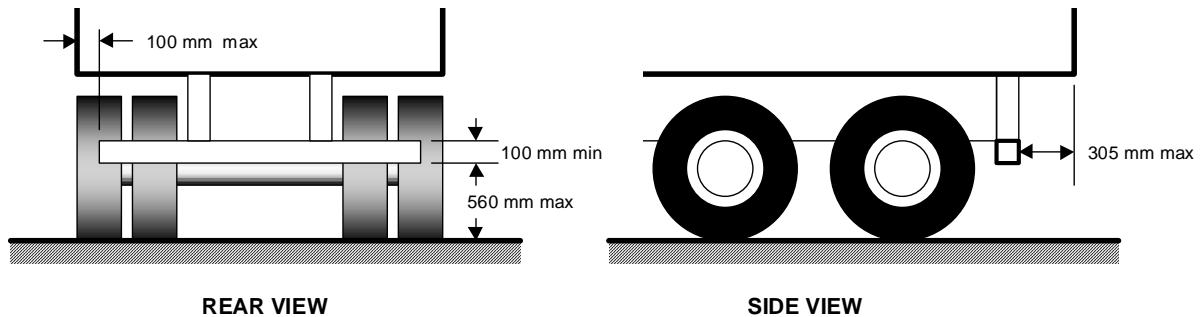

Strength requirements are that the following forces applied 50 mm above the bottom of the guard must be resisted without deflecting the guard more than 125 mm:

- 50 kN applied to a point measured $3/8^{\text{th}}$ of the barrier length from the centre line of the barrier (points P1 above);
- 50 kN applied to the centre line of the barrier (point P3 above);
- 100 kN applied to a point measured 355 – 635 mm from the centre line of the barrier, with a requirement that at this point at least 5650 J of energy is absorbed in the first 125 mm of deflection (points P2 above).

SIDE UNDERRUN PROTECTION

ECE Regulation No 73 – Lateral Protection of Trailers and Semi-trailer goods vehicles

The dimensional requirements are primarily as shown below with some additional requirements related to specific situations or vehicle types.

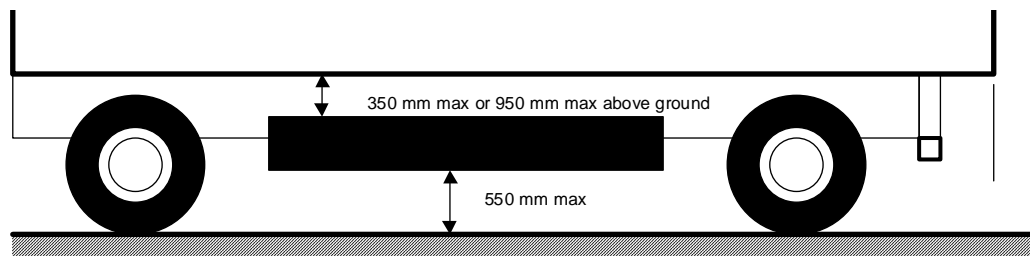

SIDE VIEW

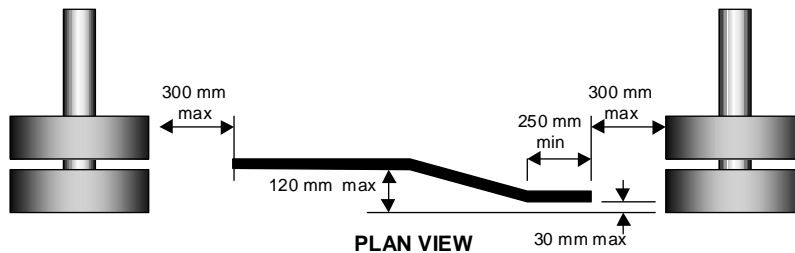

PLAN VIEW

Strength requirements are the structure be capable of resisting a horizontal force of 1 kN applied to any part of the structure through a circular flat plate of diameter 220 mm +/- 10 mm. The deflection of the guard under load shall be not more than:

- 30 mm over the rearmost 250 mm of the guard, and
- 150 mm over the remainder of the guard

FRONT UNDERRUN PROTECTION

ECE Regulation No 93 – Front Underrun Protective devices

The dimensional requirements are primarily as shown in the diagram below.

Strength requirements are as detailed below subject to the maximum deflection under load being 400 mm:

- a horizontal force of is to be successively applied as rapidly as possible at a height of no more than 445 mm above the ground to the points P1. The magnitude of this force is 80 kN or 50% of the maximum weight of the vehicle, whichever is the lesser.
- a horizontal force of is to be successively applied as rapidly as possible at a height of no more than 445 mm above the ground to the points P2. The magnitude of this force is 160 kN or 100% of the maximum weight of the vehicle, whichever is the lesser.
- where the device has reduced cross section between the two points P2, a horizontal force is to be applied as rapidly as possible at a height of no more than 445 mm above the ground to the point P3. The magnitude of this force is 80 kN or 50% of the maximum weight of the vehicle, whichever is the lesser.

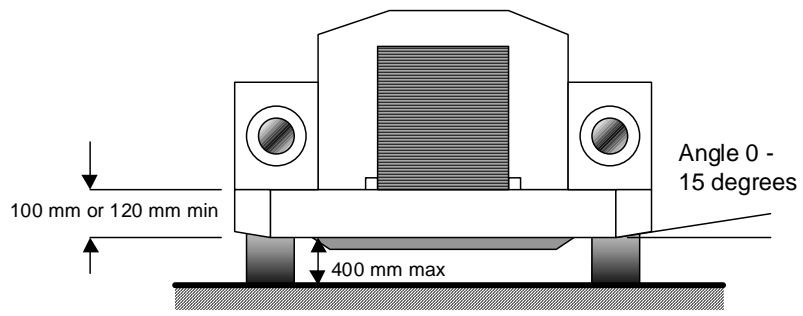

FRONT ELEVATION

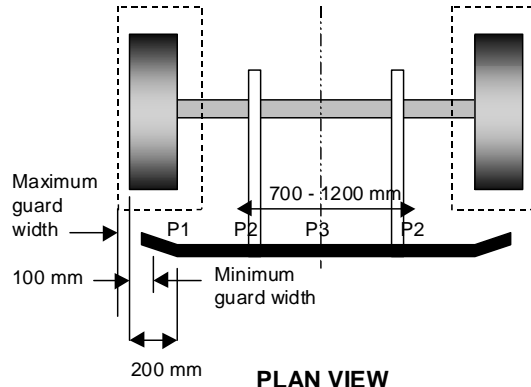

PLAN VIEW

REFERENCES

- BLOCH, Byron, (1997) Underride Guards: Is the New NHTSA Regulation Good Enough, Auto Safety Design; SAE Heavy Vehicle Underride Protection TOPTEC Conference presentation, April 15-16, Palm Springs
- BLOCH, Byron and SCHMUTZLER L. O. Improved Crashworthy Design for Truck Underride Guards: 16th ESV, May 31 – June 4, 1998, Windsor
- BRAVER, Elisa R, (1997) Comparison of Incidence of Large Truck – Passenger Vehicle Underride crashes in the Fatal Accident Reporting System and the National Accident Sampling System and a Photograph-based Study. Insurance Institute for Highway Safety; SAE Heavy Vehicle Underride Protection TOPTEC Conference presentation, April 15-16, Palm Springs
- CAMERON, M. (1990). Interim reports from accident data analysis project. Monash University Accident Research Centre,
- DANNER, M. and LANGWIEDER, K. (1981). Results of an analysis of truck accidents and possibilities of reducing their consequences discussed on the basis of car-to-truck crash tests. SAE 811027, Society of Automotive Engineers, Inc.
- DANNER, M., LANGWEIDER, L., BÄUMIER, H. (1991) Typical Risk Situations in Car-to-Truck Accidents; The Necessity to Improve the Conspicuity of Trucks. 13th ESV Conference, Paris, November 1991
- De COO, Peter J A, (1997) EEEVC Working Group 14 Activities in Energy-Absorbing Front Underrun Protection., Road-Vehicles Research Institute, Crash Safety research Centre; SAE Heavy Vehicle Underride Protection TOPTEC Conference presentation, April 15-16, Palm Springs
- DENEYS N J and RYDER M O, 1971 Underride/Override of Automobile Front Structures in Intervehicular Collisions VI – Rear Underride. Cornell Aeronautical Laboratory NY, for US DIT, NHTSA
- GLOYNS, P.F. and RATTENBURY, S.J. (1989). Cars in conflict with larger vehicles - the problem of under-run. SP782 SAE.
- GOUDSWAARD, A. P., NIEBOER, J. J., JANSSEN, E. G. (1991). Truck Front Underrun Protection. TNO Road-Vehicles Research Institute, Netherlands. IRCOBI 1991, Berlin.
- HAWORTH, N., VULCAN, P., FOONG CHEE WAI. (1991). Analysis of Australian data on truck accidents and assessment of data sources: Australian truck safety study task 5. Australian Road Research Board, Victoria. ARR 205
- HOGSTROM, K. and SVENSSON, L. (1986). Accident analysis: front, side and rear protection of trucks. Int. J. of Vehicle Design, Special issue on vehicle safety, 1986.
- KAESER, R., WALZ, F. H., BRUNNER, A. (1992) Collision Safety of a Hard Shell, Low Mass Vehicle. IRCOBI Conference, Verona, Italy. September 1992

LANGWIEDER, K. and DANNER, M. (1987) Priorities in the active and passive safety of trucks. Eleventh International Technical Conference on Experimental Safety Vehicles (ESV), Washington, May 1987.

LAU, Edmund, (1997) Heavy truck Underride risk analysis. Edmund Lau, Failure Analysis Associates; SAE Heavy Vehicle Underride Protection TOPTEC Conference presentation, April 15-16, Palm Springs

MACKAY, M AND WALTON, A. (1984). Heavy Commercial Vehicle Design and Other Road Users. Accident Research Unit, Department of Transportation, Birmingham, England. 28th Annual Proceedings, American Association for Automotive Medicine, Colorado.

MCLEAN, A.J. (1966). Engineering aspects of traffic accidents in Adelaide, South Australia. University of Adelaide.

MOFFAT C A and WONG J (1980) Improved Underride Protection in Moderate Speed Crashes; Proceedings AAAM Oct 7-9, 1980

MOUCHAHOIR, George E, (1997) Federal Motor Vehicle Safety Standards Requirements for Rear Underride Protection. US Department of Transportation, NHTSA; SAE Heavy Vehicle Underride Protection TOPTEC Conference presentation, April 15-16, Palm Springs

MURRAY, N.W. (1988). Study of car-truck impacts and the feasibility of fitting energy-absorbing guards to heavy trucks. Monash University, Dept. of Civil Engineering.

OGDEN, K.W. and TAN, H.W. (1987). Truck involvement in fatal road accidents. Civil Engineering Working Paper, 87/14, Dept. of Civil Engineering, Monash University.

OTTE, D. (1987). Collision situations and consequences of injuries in traffic accidents of heavy trucks. OECD symposium on the role of heavy freight vehicles in traffic accidents., Montreal, OECD.

PRASAD, Alope K, (1997) Heavy Vehicle Frontal Aggressiveness: Crash Test Results with Countermeasure Concepts. Transportation Research Center, Vehicle research and Test Center, US Department of Transportation; SAE Heavy Vehicle Underride Protection TOPTEC Conference presentation, April 15-16, Palm Springs

PRASAD. ALOKE K.. GUGLIELMI. JOHN P.. MONK. M. W. (1996) A Study of the Heavy Truck to Light Vehicle Accident Environment. Report No. VRTC- 81- 0198. National Highway Traffic Safety Administration. U.S. Department of Transportation

RECHNITZER, G. and FOONG CHEE WAI. (1991) Fatal and Injury Crashes of Cars into the Rear of Trucks. Monash University Accident Research Centre, Melbourne. Report No. 26.

RECHNITZER, George (1993) Truck Involved Crash Study – Fatal and injury crashes of cars and other road users with the front and sides of heavy vehicles. Monash University Accident Research Centre, Melbourne. Report No. 35.

RECHNITZER, G., SCOTT, G. & MURRAY, N.W., (1993). Design and Testing of Effective Rear Underrun Barriers for Heavy Vehicles. Dynamic Loading in Manufacturing

and Service, Melbourne. 9-11 February 1993. The Institute of Engineers, Australia, pp 189-198 (National Conference Publication No. 93/1)

RECHNITZER, G., SCOTT G. & MURRAY, N.W., (1993). 'The Reduction of Injuries to Car Occupants in Rear End Impacts with Heavy Vehicles'; 37th STAPP Car Crash Conference, 8-10 Nov. 1993, San Antonio, Texas. paper 933123, SAE Inter.

RECHNITZER, POWELL AND SEYERS, (1996) Development and testing of Energy Absorbing Rear Underrun Barriers for heavy Vehicles, 15th International Technical Conference on the Enhanced Safety of Vehicles, May 13- 16; Paper No. 96-S4-O-10, World Congress Centre. Melbourne.

RECHNITZER, (1997) Design Principles for Underride guards and Crash Test results, SAE Heavy Vehicle Underride Protection TOPTEC Conference presentation, April 15-16, Palm Springs

RECHNITZER, (2000) Energy Absorbing Rear Underrun Barriers for Heavy vehicles, Vehicle Safety Standards Branch, Land Transport Division, Department of Transport and Regional Services, Draft Report VSSB 2

RECHNITZER G, POWELL C AND SEYERS K, (2001) Performance Criteria, Design and Crash Tests of Effective Rear Underride Barriers for Heavy Vehicles, Paper No 218

RILEY, B.S. and BATES, H. J. (1980) Fatal Accidents in Great Britain in 1976 involving heavy goods vehicles. TRRL Supplementary Report No. 586. Transport and Road Research Laboratory, Department of Transport, Berkshire, UK.

RILEY, B.S., CHINN, B.P. and BATES, H.J. (1981). An analysis of fatalities in heavy goods vehicle accidents. TRRL Laboratory Report 1033, Berkshire, Transport and Road Research Laboratory, Department of the Environment Department of Transport.

RILEY, B. S., PENOYRE, S., BATES, H. J. (1985). Protecting Car Occupants, Pedestrians, and Cyclists in Accidents Involving Heavy Goods Vehicles by using Front Underrun Bumpers and Sideguards. Tenth ESV Conference, Oxford, 1985.

RILEY, B. S., FARWELL, A. J., BURGESS, T. M. (1987). Front Underrun Guards for Trucks. The Eleventh ESV Conference, Washington, May 1987.

ROBINSON, B. J. AND RILEY, B. S. (1991). Improving HGV Safety - Front Underrun Guards and Anti-Lock Braking Systems. The Thirteenth International Technical Conference on Experimental Safety Vehicles (Paris 1991).

SWEATMAN, P., OGDEN, K., HAWORTH, N., PEARSON, R. and VULCAN, P. (1990). Heavy vehicle safety on major NSW highways: a study of crashes and countermeasures. Roseberry, N.S.W., Roads and Traffic Authority, NSW.

SWEATMAN, PF OGDEN, KW HAWORTH, N CORBEN, B RECHNITZER G and DIAMANTOPOULOU, K (1995) Heavy Vehicle Crashes in Urban Areas, CR 155, 1995 Federal Office of Road Safety

THOMAS, P., AND CLIFT, L. (1988) Analysis of fatal accidents involving heavy goods vehicles - front underrun accidents in 1988. Transport and Road Research Laboratory, Department of Transport, Berkshire, UK Contractors Report 289.

Truck Underride Studies - Cornell 1970: IIHS –1977 and Dynamic Science, 1980

WALZ, F. H., STRUB, C., BAUMANN, U., MARTY, W. (1990) Collisions of Heavy Trucks Against Cars, Two-Wheelers and Pedestrians. IRCOBI Conference, Bron-Lyon Sept 1990.

WELBOURNE, E R, and BOUCHER, D, (1997)Underride collisions – A Canadian Perspective., Transport Canada; SAE Heavy Vehicle Underride Protection TOPTEC Conference presentation, April 15-16, Palm Springs