



MONASH University

Accident Research Centre

WINDSCREENS AND SAFETY: A REVIEW

by
Nicola Pronk
Brian Fildes
Michael Regan
Michael Lenné
Niklas Truedsson
Ted Olsson

2001

Report No. 183

MONASH UNIVERSITY ACCIDENT RESEARCH CENTRE
REPORT DOCUMENTATION PAGE

Report No.	Date	ISBN	Pages
183	April 2001	0 7326 1482 1	76

Title and sub-title:

Windscreens and Safety: A Review

Author(s)

Pronk, N., Fildes, B., Regan, M., Lenné, M.,
Truedsson, N., & Olsson, T.

Type of Report & Period Covered

GENERAL, 2001

Sponsoring Organisation(s):

This project was funded by;

- Federal Office of Road Safety
 - Perfect Glass
 - Pilkington
 - VicRoads
 - Windscreens O'Brien
-

Abstract:

This report describes the research outcomes of a review examining the link between windscreen degradation and road safety. Different types of windscreen damage were identified including sudden impact damage such as cracks and “bulls eyes” and gradual degradation resulting from the constant wear of the surface by small particles such as sand and dirt. The effect of gradual degradation on driving safety has been the focus of this project. A review of the international literature identified a number of studies that suggest that windscreen degradation may impair driver perception. Little research was identified that directly examined the link between windscreen degradation and crash involvement. Relevant national and international standards, regulations and guidelines relating to windscreens were summarised, and devices that can measure windscreen degradation were identified. Finally, recommendations were made for the future direction of the project.

Key Words:

windscreen, windshield, degradation,
damage, sandblasting, haze, driver
perception

Disclaimer

This report is disseminated in the interest of information exchange. The views expressed here are those of the authors, and not necessarily those of Monash University or the sponsors

Reproduction of this page is authorised

Monash University Accident Research Centre,
Wellington Road, Clayton, Victoria, 3800, Australia.
Telephone: +61 3 9905 4371, Fax: +61 3 9905 4363

CONTENTS

EXECUTIVE SUMMARY	IX
GLOSSARY	XIV
1 INTRODUCTION	1
1.1 PROJECT BACKGROUND	1
1.2 PROJECT MANAGEMENT.....	2
1.3 RESEARCH METHODS	2
1.3.1 Databases	3
1.3.2 Search Terms	3
1.3.3 Other	3
1.3.4 Overseas Research Organisations.....	3
1.4 PREAMBLE	4
2 WINDSCREENS AND SAFETY	7
2.1 TYPES OF WINDSCREEN VISIBILITY DEGRADATION	7
2.1.1 Sudden Impact Damage.....	7
2.1.2 Degradation and Wear	7
2.1.3 Soiling	8
2.1.4 De-lamination.....	9
2.1.5 “Milkiness”	9
2.1.6 Migration of the Plasticiser	9
2.1.7 Reflections from the Dashboard.....	10
2.2 STRAY LIGHT	10
2.2.1 The Physics of Stray Light (Kessler, 1991).....	11
2.2.2 Types of Windscreen Damage and Stray Light.....	11
2.2.3 Stray Light and Driving.....	12
2.3 THE LINK BETWEEN WINDSCREEN DEGRADATION AND SAFETY	12
2.3.1 The Impact on Perception.....	12
2.3.2 Field and Laboratory Studies.....	14
2.3.3 The Crash Link	19
3 REGULATIONS AND GUIDELINES FOR WINDSCREEN INTEGRITY	21
3.1 THE MOTOR VEHICLE STANDARDS ACT 1989	21
3.2 AUSTRALIAN DESIGN RULES FOR MOTOR VEHICLES AND TRAILERS (3 RD EDITION).....	21
3.2.1 Australian Design Rule 8/00 Safety Glazing Material	22
3.3 AUSTRALIAN / NEW ZEALAND STANDARDS	22

3.3.1	AS/NZS 2080: 1995 Safety glass for land vehicles.....	23
3.3.2	AS/NZS 2366.1: 1999 Windscreen repairs. Part 1: Repair procedures	24
3.3.3	AS/NZS 2366.2: 1999 Windscreen repairs. Part 2: Repair systems	26
3.4	OVERSEAS STANDARDS	27
3.4.1	United Nations – European Standard. Uniform Provisions Concerning the Approval of Safety Glazing and Glazing Material – United Nations Agreement Concerning the Adoption of Uniform Conditions of Approval and Reciprocal Recognition of Approval for Motor Vehicle Equipment and Parts, Addendum 42: Regulation No. 43	27
3.4.2	ANSI/SAE Z26.1-1996. American National Standard for Safety Glazing Materials for Glazing Motor Vehicles and Motor Vehicle Equipment Operating on Land Highways – Safety Standard	27
3.4.3	American Standard. Standard Test Method for Haze and Luminous Transmittance of Transparent Plastics – 1977	28
3.4.4	German Standard. Road Vehicles – Measurement of scattered light of safety glazing materials for vehicle glazing. Part 1: Annular diaphragm method (DIN 52298-1, December 1998).....	29
3.4.5	JIS R 3211: 1998. Japanese Industrial Standard. Safety Glazing Materials for Road Vehicles.	29
3.4.6	JIS R 3212: 1998. Japanese Industrial Standard. Test Method of Safety Glazing Materials for Road Vehicles.	30
3.4.7	BS AU 242: 1991. British Standard. Automotive Windscreen Repair.....	31
3.4.8	AGE AU 251. British Standard. Part I – Specification for Performance of Automotive Laminated Windscreen Repair Systems. Part II – Code of Practice on Repair Methodology	32
3.5	AUSTRALIAN ROADWORTHINESS GUIDELINES	33
3.5.1	National Road Transport Commission’s “Roadworthiness Guidelines”, September 1995	33
3.5.2	Victoria	35
3.5.3	New South Wales	36
3.5.4	Tasmania.....	36
3.5.5	Australian Capital Territory.....	39
3.5.6	South Australia	40
3.5.7	Queensland	40
3.5.8	Northern Territory.....	41
3.5.9	Western Australia	41
3.6	ADMINISTRATIVE GUIDELINES: ASSESSMENT OF DEFECTIVE VEHICLES (FEBRUARY 1999).....	42
3.6.1	National Road Transport Commission’s Classification of Windscreen Damage	42
4	MEASUREMENT OF WINDSCREEN DEGRADATION.....	45
4.1	AN EARLY TECHNIQUE TO MEASURE WINDSCREEN DEGRADATION	45
4.2	MODERN TECHNIQUES FOR MEASURING WINDSCREEN DEGRADATION.....	45
4.3	STRAY LIGHT.....	49

4.4	THE STRAY LIGHT INDEX AS A MEASURE OF WINDSCREEN DEGRADATION...	51
4.4.1	The Angular Diaphragm Method of Measuring Scattered Light.....	53
4.4.2	Hand Held Devices for Measuring Stray Light	55
4.5	AVIATION MEASURES.....	58
5	WHERE TO FROM HERE?.....	59
5.1	FUTURE RESEARCH.....	59
5.1.1	The Link Between Windscreen Degradation and Safety.....	59
5.1.2	Measurement Device	60
5.1.3	Development of a Suitable Standard	60
5.2	CONCLUSION.....	60
	REFERENCES	61

EXECUTIVE SUMMARY

LITERATURE REVIEW

Types of Windscreen Visibility Degradation

Damage to windscreens typically falls into two categories; sudden impact damage and degradation or wear.

Sudden impact damage includes cracks and “bulls eyes”. Only a couple of studies were identified that considered this type of damage. One suggested that this type of damage may be distracting to drivers (though this was not supported by research) and the other concluded that this type of damage seemed to cause less of a visual problem than the multiple fine scratches and chips resulting from gradual wear.

Windscreens wear and degrade over time. Through use they are continuously bombarded by small particles such as tiny rocks, sand and dirt that wear the surface. Further to this, windscreen wipers can damage the windscreen over time by scratching tiny particles across the surface.

Another factor that may compound the effects of windscreen degradation is soiling. It was suggested that grease and grime may result in the production of scattered light and further, that the removal of the grease and grime may result in the windscreen being scratched and damaged.

De-lamination and “miliness” can also impact negatively upon the quality of windscreens. Delamination occurs when one or both of the layers of the glass separate from the polyvinylbutyrate interlayer. This can cause different optical effects. Miliness occurs when the polyvinylbutyral layer separates from the layers of glass and starts to return to its original prelaminated state. The windscreen can start to become opaque and cause difficulty for the driver.

Migration of the plasticiser can occur following exposure to sun. Under this condition the plasticiser can be liberated from the dashboard and form a thin film on the inside surface of the windscreen. This build up can cause problems for drivers including distortion of incoming light.

Many vehicles have dashboards that are made from plastic that, in certain light, reflects an image from the dashboard onto the windscreen. This reflection may cause distraction to the driver.

Stray Light

When light travels along a path without disturbance it is called “useful light”. However the light path can be disturbed causing the beam to change in some way. Light that has been disturbed is referred to as “stray light”. The intensity of stray light depends on the scattering angle and the intensity of the original beam.

Stray light can be generated in soiled or surface damaged windscreens. During the daylight the eye is adapted to stronger light with many different wavelengths, therefore the impact of stray light is not very severe at this time. However in the case of suddenly appearing light sources, such as on-coming headlights at night, the light that hits the windscreen can be deflected into the driver’s eye by means of wide angle light scattering, causing disturbances in vision and perception.

Different types of windscreen damage can result in different stray light effects. For example, small chips tend to scatter light with a halo around the light source, while scratches and grooves tend to scatter light perpendicular to the damaged area and add one or two “tails” to the light source.

The Link between Windscreen Degradation and Safety

Findings from several studies suggest that stray light can have a negative impact on driver perception.

A number of field and laboratory studies (some using a driving simulator) were identified that considered the effects of worn windscreens on driver perception. Some of the key findings from these studies included:

- drivers may take longer to re-adapt their vision following exposure to the stray light effects created through a worn windscreen (“dazzling”);
- detection distances to objects on the road ahead may be reduced when looking through worn windscreens with stray light effects. Further, the contrast of objects on the road ahead may be reduced by stray light and a consequence of this could be a reduction of visibility distances;
- while detection distances may be reduced when driving with a worn windscreen, drivers seem to adapt their speed to their abilities. One study found that those with the best visual performances drove the fastest;
- drivers do seem to be able to view objects at a distance when looking through a worn windscreen despite previous research suggesting that this could be a problem (the “Mandelbaum” effect);
- dirty windscreens seemed to cause drivers to crash twice as often in a driving simulator (as compared to driving with a new windscreen) and when driving with a degraded windscreen, drivers reaction times to a secondary task may be slowed. The authors of this study concluded that driving with a visually degraded windscreen induces fatigue and performance declines more rapidly than when driving with a non-degraded windscreen; and
- older participants may find stray light effects (“glare”) to be more debilitating compared with younger participants.

Very few studies were identified that attempted to quantitatively establish a link between windscreen degradation and crash involvement. Only one simulation study examined the relationship between windscreen degradation and crashes. A study conducted recently in New South Wales by the RTA looking at 4000 cars (from 2500 crashes) collected, amongst other things, information relating to the state of the windscreens. The possibility of working in collaboration with the RTA could be explored in the future, to analyse this data in light of the present project.

REGULATIONS AND GUIDELINES FOR WINDSCREEN INTEGRITY

Vehicle safety requirements are specified at a number of levels.

The Motor Vehicle Standards Act 1989

The object of the Motor Vehicle Standards Act 1989 is to ensure uniform vehicle standards are applicable to all road vehicles that are used in the Australian transportation system. Essentially this is the overall governing national guideline relating to vehicle safety in Australia.

Australian Design Rules for Motor Vehicles and Trailers (3rd Edition)

The Australian Design Rules (ADRs) are national standards. The Australian Design Rules for Motor Vehicles and Trailers (3rd Edition) form part of the National Standards determined under section 7 of the Motor Vehicle Standards Act (current Act was passed in 1989).

The ADRs set out the design standards for vehicle safety. All cars that are first supplied to the Australian market are required to comply with these. This includes vehicles manufactured in Australia as well as those imported from overseas.

The following ADR was identified as being relevant to the present project.

- Australian Design Rule 8/00 Safety Glazing Material

Australian / New Zealand Standards

The aim of standards is to regulate the industry of concern to maintain a minimum level of safety.

The following Australian/New Zealand standards were identified as being relevant to the present project.

- AS/NZS 2080:1995 Safety glass for land vehicles
- AS/NZS 2366.1:1999 Windscreen repairs: Part 1: Repair procedures
- AS/NZS 2366.2:1999 Windscreen repairs: Part 2: Repair systems

Overseas Standards

Several overseas standards were identified.

- United Nations – European Standard. Uniform Provisions Concerning the Approval of Safety Glazing and Glazing Material – United Nations Agreement Concerning the Adoption of Uniform Conditions of Approval and Reciprocal Recognition of Approval for Motor Vehicle Equipment and Parts, Addendum 42: Regulation No. 43
- ANSI/SAE Z26.1-1996. American National Standard for Safety Glazing Materials for Glazing Motor Vehicles and Motor Vehicle Equipment Operating on Land Highways – Safety Standard
- American Standard. Standard Test Method for Haze and Luminous Transmittance of Transparent Plastics – 1977.
- German Standard. Road Vehicles – Measurement of scattered light of safety glazing materials for vehicle glazing. Part 1: Annular diaphragm method.

- JIS R 3211:1998. Japanese Industrial Standard. Safety Glazing Materials for Road Vehicles.
- JIS R 3212:1998. Japanese Industrial Standard. Test Method of Safety Glazing Materials for Road Vehicles.
- BS AU 242:1991. British Standard. Automotive Windscreen Repair.
- AGE AU 251. British Standard. Part I – Specification for Performance of Automotive Laminated Windscreen Repair Systems. Part II – Code of Practice on Repair Methodology.

AUSTRALIAN ROADWORTHINESS GUIDELINES

Vehicle roadworthiness guidelines define legal requirements to ensure a minimum level of safety for vehicles. They focus on the safety related aspects of vehicles and aim to ensure that parts have not worn or deteriorated to an extent that they have rendered the vehicle unsafe for use.

The National Road Transport Commission (NRTC) released draft “Roadworthiness Guidelines” in September 1995 as part of their task to develop uniform laws and administrative guidelines for the “safe and efficient operation of road transport in Australia” (p1 of the draft document).

Several Australian jurisdictions have based their roadworthiness guidelines directly on this document.

In this section the guidelines used in each State and Territory of Australia were summarised.

ADMINISTRATIVE GUIDELINES: ASSESSMENT OF DEFECTIVE VEHICLES (FEBRUARY 1999)

The NRTC Administrative Guideline for the Assessment of Defective Vehicles was designed “to help enforcement officers determine the significance of vehicle defects relative to the safety risk they present on the road” (Explanatory Notes to the document).

This document classifies different types of windscreen damage.

MEASUREMENT OF WINDSCREEN DEGRADATION

This section of the report describes and reviews devices and techniques that are currently available to measure windscreen degradation.

Early and Modern Techniques

One of the first techniques for measuring the extent of windscreen degradation was a laboratory-based technique (Allen, 1969). It involved taking photographs of the headlights of an oncoming car through the windscreen. To measure the extent of light scatter, layers of translucent plastic polyethylene were layered over the photograph of the scratch pattern until the scratch pattern could barely be seen. The number of layers provided a crude index of the extent of windscreen scratching.

Modern techniques express the degree of windscreen degradation in terms of the ratio of the intensity of the stray light to the intensity of useful light, as it is believed that this ratio is

critical for the driver (Timmermann, 1985b). This ratio is called the reduced luminance coefficient and is also referred to as the Scattered Light Index (SLI). The higher the SLI, the greater the degree of light scattering and hence windscreen degradation.

The “Hazemeter” (American standard D 1003-61) is a device that was originally developed in the 1960s (and re-approved in the 1970s) for testing for haze and luminous transmittance of transparent plastics. The general design and procedure of this device are described.

Stray Light

Derkum (1991a) identified that stray light emanating from different types of windscreen damage (eg: craters, wiper damage, scratches) produces different types of distributions. Derkum also suggested that the effects produced by different types of damage could have differing effects on driver perception. Further, as windscreen damage may not be uniform across the windscreen, it may be important to consider the location of the damage. This author suggested that it is important to consider both the specific type of damage in addition to the stray light mean value.

The Stray Light Index as a Measure of Windscreen Degradation

Two portable windscreen measurement devices were identified.

A device to measure stray light effects developed by Schwahn Systems, the “StrayLizer”, was identified and the measurement technique described.

Another device, the “IRIS 504SC”, developed by DMO Optical Solutions was also identified and described.

Aviation Measures

Haze has been measured in aircraft transparencies using a Hazemeter. A portable device, the “Haze-o-Meter II”, developed by Armstrong Laboratories for the United States Air Force, was also identified however little information is available regarding this device.

WHERE TO FROM HERE?

Finally, a research strategy was outlined that could further identify the extent of the windscreen/safety problem and also identify means for improving windscreen safety. This strategy includes defining the extent of the problem (using a crash study and performance study), developing a suitable measurement device, and the development of a suitable standard.

GLOSSARY

Bulls eyes	A type of sudden impact damage to windscreens
Cracks	A type of sudden impact damage to windscreens
De-lamination	A form of windscreen damage that occurs when one or both of the layers of the glass separate from the polyvinylbutyrate layer
Ghost Image	An illusion that may appear to drivers, as a result of scattering light in a degraded windscreen
Haze	The resulting effects of sandblasting, whereby vision may be compromised due to the presence of stray light effects
Milkiness	A form of windscreen damage that occurs when the polyvinylbutyral layer separates from the layers of glass and start to return to its prelaminated state
Primary vision area	The area believed to be most important for drivers' vision.
Sandblasting	The process whereby sand and dirt particles abrade the surface of a windscreen over time
Stray Light	Light that is not transmitted parallel to the main direction of the incoming light due to some type of interference such as damage or soiling
Windscreen	Glass viewing area at the front of a vehicle (term favoured in Australia)
Windshield	Glass viewing area at the front of a vehicle (term favoured in USA)

1 INTRODUCTION

1.1 PROJECT BACKGROUND

In 1997 representatives from the Monash University Accident Research Centre (MUARC), VicRoads and Windscreens O'Brien convened a meeting in Sydney to discuss the suitability of current roadworthy standards adopted by road authorities for determining whether windscreens should be replaced on safety grounds. The impetus for the meeting was a concern by Windscreens O'Brien and VicRoads that current procedures are less than adequate. As a result of that meeting, and several meetings that followed, MUARC was jointly commissioned by several organisations (Windscreens O'Brien, Pilkington, Perfect Glass, Federal Office of Road Safety & VicRoads) to scope and conduct a research study with the following objectives:

- increase our understanding of the effects of windscreen degradation, due to normal wear and tear, on driving performance and crash risk;
- develop standardised criteria for determining whether a degraded windscreen should be replaced or repaired;
- develop and validate a low-cost prototype device for objectively measuring windscreen degradation against these criteria; and
- determine appropriate strategies for implementing the findings to improve road safety.

This report describes the research outcomes of activities relating to the first of these objectives.

1.2 PROJECT MANAGEMENT

The Monash University Accident Research Centre (MUARC) was commissioned to undertake and manage the project under the direction of a steering committee comprising the following members:

- Mr Kim Elliott, Australian Automotive Aftermarket Association (Chair)
- Mr Bevan Simms, Novus Windscreen Repairs
- Mr Vincent Lim, VIPAC Engineers & Scientists
- Mr John Grasso, VicRoads
- Dr Darryl Yaniuk, Windscreens O'Brien
- Mr Malcolm Preston, SAE
- Dr Michael Regan, Monash University Accident Research Centre
- Professor Brian Fildes, Monash University Accident Research Centre
- Mr Kim Foster, Pilkington
- Mr Stan Graczyk, Novus Windscreen Repairs
- Mr Michael Smith, VIPAC Engineers & Scientists
- Mr Stuart Ballingall, RACV
- Mr Patrice Doherty-Bigara, Perfect Glass
- Mr Keith Seyer, Vehicle Safety Standards Branch, Land Division, Department of Transport and Regional Services

A subset of these organisations was appointed to act as a technical advisory group to assist MUARC in undertaking its activities. The following organisations comprise the technical working group, which met for the first time on the 22nd July 1999:

- Mr Kim Elliott, Australian Automotive Aftermarket Association (Chair)
- Mr John Grasso, VicRoads
- Mr Vincent Lim, VIPAC Engineers & Scientists
- Dr Darryl Yaniuk, Windcreens O'Brien
- Professor Brian Fildes, Monash University Accident Research Centre
- Mr Kim Foster, Pilkington
- Mr Stan Graczyk, Novus Windscreen Repairs
- Mr Patrice Doherty-Bigara, Perfect Glass
- Dr Michael Regan, Monash University Accident Research Centre

The Australian Automotive Aftermarket Association (AAAA) was appointed as the secretariat for the project team.

1.3 RESEARCH METHODS

As noted above, this report documents the outcomes of research activities designed to increase our understanding of the effects of windscreen degradation, due to normal wear

and tear, on driving performance and crash risk. The following method was used to source relevant documents for the literature review.

1.3.1 Databases

The following databases were searched:

- Road
- RoadRes
- SAE
- Highway Vehicle Safety
- Transport
- PsycLit / PsycINFO
- Current Contents
- Medline
- Wilson Applied Science and Technology
- Wilson General Science Abstracts

1.3.2 Search Terms

The following search terms were used when searching the above databases:

- Windscreen(s)
- Windshield(s)
- Damage
- Visibility, vision
- Safety
- Crack, chip, scratch
- Hazard identification
- Perception
- Scatter
- Scattered light
- Wear, degradation
- Light transmittance

1.3.3 Other

Other resources were also used to locate relevant documents:

- the Internet; and
- Vision in Vehicles Conference Proceedings.

1.3.4 Overseas Research Organisations

Previous experience has shown that not all Human Factors and safety research finds its way into published journals because many applied research centres are expected to produce research reports only rather than journal papers. Therefore, centres known to have particular expertise and / or recent experience in the area were contacted to ensure a thorough literature search was conducted. The following researchers (and organisations) were contacted during this search:

- Dr. Michael Sivak at the University of Michigan Transport Research Institute, USA;
- Professor Rudolf Mortimer of the University of Illinois, USA;
- Dr. David Shinar of the Ben-Gurion University, Israel, and consultant to the National Highway Traffic safety Administration in Washington DC, USA;
- Dr. Gabriel Helmers of the Swedish Road and Traffic Safety Institute (VTI), Sweden;
- Professor Kare Rumar of the Swedish National Road Administration, Sweden;
- Pete Thomas of ICE Ergonomics at the University of Loughborough, UK; and
- Dean Southall of ICE Ergonomics at the University of Loughborough, UK.

1.4 PREAMBLE

Before documenting the outputs of the research activities conducted, it is appropriate to introduce some of the key terminology used throughout this report.

The windscreen is designed to enhance visibility of the traffic environment and, in more recent times, to contribute to the structural integrity of the vehicle. In some vehicles the windscreen is designed to contribute to the overall structural strength and may be required to play a significant role in the deployment of driver and passenger airbags. In terms of optical requirements, which are the focus of this report, Kessler (1991) has defined the role of the windscreen as follows:

“In most cases optical information for the driver of a vehicle passes through the windshield or side and rear windows of the driver’s cabin. The optical transformation properties of the windshield and windows therefore play an important role in the conservation of correct information. Moreover, the windshield should not be the source of additional irregular information which leads to a misunderstanding of the surroundings and, as a result, to dangerous reactions of the driver” (p 69).

Windscreen damage can take a number of forms:

- overt damage from impacts (eg: cracks, “bulls eyes”); and
- gradual degradation (eg: small chips and scratches that can result in “haze”).

Cracks and “bulls eyes” can occur in windscreens following an impact. This type of damage usually occurs as the result of a discrete incident or incidents and would be immediately visible to the naked eye.

Further to this, windscreens degrade over time and with normal vehicle use. The windscreen surface wears (or is “sandblasted”) from the constant insult of small stones, gravel and dust. Generally sandblasting occurs over an extended period of time and may not be immediately apparent to drivers. The speed of such degradation can be influenced by factors such as the environment, the type of driving and care of the windscreen. Further the presence of dirt and grime on either side of the windscreen may also amplify the negative effects of this degradation. The effects of this type of damage is often referred to as “haze”.

It should also be noted that the windscreen can be broken down into a number of areas of relative importance for drivers. For example, the primary vision area is the area that is believed to be most important for drivers’ vision. The location of damage to windscreens seems to be a factor that is important when considering windscreen damage and degradation. The SAE document *Motor Vehicle Drivers Eye Range – SAE J941c* establishes two-dimensional ellipses that represent the 90th, 95th and 99th percentile increments of driver eye locations and describes procedures for their use. Such guidelines could be used to help identify the most important areas on a windscreen for drivers.

The terms “windscreen” and “windshield” have been used interchangeably in the international literature and both refer to the glass viewing area at the front of the vehicle. The term “windscreen” is favoured in Australia and will be used throughout this report.

It should be noted that other factors relating to windscreens have been discussed in the literature as potentially having an impact upon driver safety. For example the issue of windscreens and window tinting has attracted much attention and lies at the centre of contentious debate. A discussion of this and other factors is beyond the scope of the present project. It is recognised however that such factors may have an impact on driver

safety and may exacerbate the problems associated with various types of windscreen damage.

The remainder of this report reviews what is known about windscreen damage and safety, regulations and guidelines for design, repair and replacement of windscreens, and the measurement of windscreen degradation.

2 WINDSCREENS AND SAFETY

This section of the report summarises and reviews the international literature relating to windscreen damage or degradation and driving safety.

2.1 TYPES OF WINDSCREEN VISIBILITY DEGRADATION

As noted previously damage to a windscreen typically falls into the following categories:

1. sudden impact damage (in the form of cracks or “bulls eyes”); and
2. degradation or wear (also known as “haze”).

In the following sections literature is reviewed relating to the different types of damage.

2.1.1 Sudden Impact Damage

In their short article¹ discussing the revised joint Australian / New Zealand Standard, AS/NZS 2366, Windscreen repairs Part 1: Repair Procedures and Part 2: Repair Systems, Jabbour (1999) stated that “cracks or chips on the windscreen can obscure driver vision, particularly at night, they can distract driver attention, depending on where the damage is, and can be a contributory factor in a road accident”.

Allen (1974) evaluated the ability to see through dirty and surface damaged windscreens, in both a static and dynamic driving situation. He used photographs to record the amount of scattered light (created by a simulated on-coming headlight) and the surface condition of each windscreen. Deep scratches were identified in a sample of the windscreens that he examined and he concluded that they seemed to cause less of a visual problem through the windscreen than the multiple fine scratches and chips resulting from gradual wear.

2.1.2 Degradation and Wear

Windscreens wear and degrade over time. Through use, they are continuously bombarded by small particles such as tiny rocks, sand and dirt that wear the surface. Further to this, windscreen wipers can damage the windscreen over time by scratching tiny particles across the surface.

Such wear results in tiny scratches and chips and this is often referred to as windscreen “hazing” or “sandblasting”.

A number of authors have commented on the effects of windscreen hazing or sandblasting.

Haase, Schneider, Helmers & Timmermann (1989) concluded that windscreen wear generally occurs gradually over time (as opposed to damage that results from a sudden insult) and can be significant in its effect. These authors also stated that this type of wear can be so gradual that “it is usually not noticed” (p 33).

Studies have been conducted that have measured the degree of damage or wear to windscreens. Allen (1974) measured windshields before and after they had been polished and found that dirt and small scratches were relatively common in a sample of Melbourne cars and that many had suffered significant damage from windscreen wiper use. He concluded that windscreens do get damaged with use, that this damage could be harmful and that it resulted in increased levels of veiling glare (the issue of glare is discussed in the

¹ These authors did not cite any references supporting this assertion in this article.

“Stray Light” section below). When the surface of automobile windscreens was tested for damage that had accumulated during normal driving, a relationship was found between damage (including that from the use of windscreen wipers) and distance travelled (Allen 1969; Timmermann, 1985b). Figure 1 (below) illustrates surface wear on a windscreen at 80,000 km.

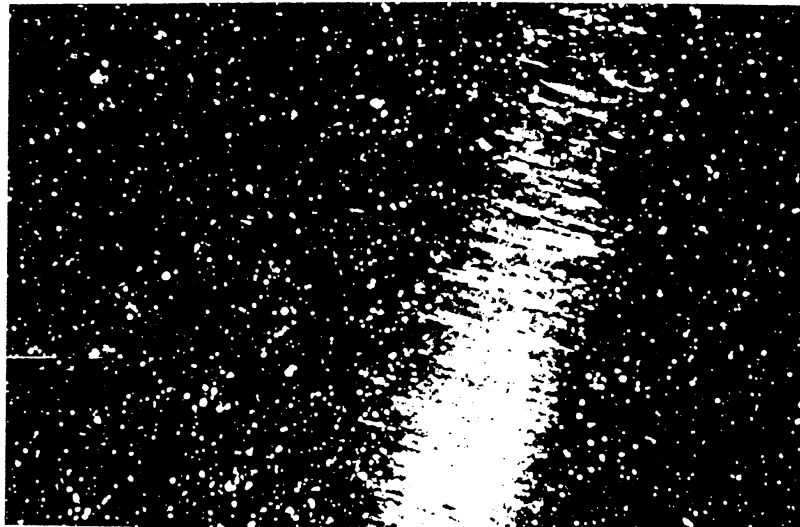

Figure 1 Surface Wear on a Windscreen at 80,000 km (Timmermann, 1985b)

However windscreen wear is not necessarily consistent across time, vehicles and regions. Timmermann (1985b) found that the windscreen of cars with similar mileage could vary significantly, depending on the type of driving done. He concluded that the difference in wear was probably due to differences in climatic and road (driving) conditions. Timmermann also found that cars that were usually parked on the street often had higher light scattering values than those that were garaged. Further to this, Derkum (1991a) collected data relating to windscreen damage in Cologne, Bavaria, and Norway and found markedly different results. He concluded that the difference in wear of the windscreens examined was most probably a result of different climatic and environmental conditions.

Allen (1969) concluded that windscreens wear with use (and can be damaged as a result of cleaning methods) and should be replaced as wear dictates as with tyres and brakes. However this author did not discuss the need for quantification of such damage.

In his book titled *Vision and Highway Safety*, Allen (1970) suggested that one simple way of testing windscreen scratch deterioration is to observe the windscreen from the outside, wearing dark glasses, and looking at the reflection of the sun in the windscreen. A deterioration free glass will show a bright sun disc on a clear background. An older, worn glass will show bright rings of scratches around the sun's image that extend out from the edge of the solar image, masking the sky image.

2.1.3 Soiling

Another factor that may compound the effects of windscreen wear and degradation is that of soiling. Allen (1974) studied the incidence and effects of windscreen dirt and surface damage. He found that the presence of dirt and scratches on the outside surface of windscreens was common in the sample of vehicles he inspected and concluded that this damage could interfere with drivers' vision, especially at night. Allen also found that scratches were present on the inside surface of windscreens, probably resulting from the removal of condensation.

Timmermann (1985a) suggested that scattered light (see below for a discussion of this issue) can result from the presence of grease or dirt (as well as damage) on the windscreen surface.

Further, dirt on the windscreen can get scratched across the windscreen by the wipers and this can result in small scratches of the surface. These scratches can increase the amount of stray light in the windscreen.

Therefore windscreens can be damaged and degraded. Such damage can result from sudden insults (to form cracks or “bulls eyes”), from the bombardment of small stones over time (causing “sandblasting”), and from cleaning methods (eg: wipers scratching dirt across the windscreen). Soiling can also degrade windscreens. Allen (1974) has suggested that windscreens may need to be repaired (where possible) or replaced as wear dictates as with tyres and brakes.

2.1.4 De-lamination

Delamination occurs when one or both of the layers of the glass separate from the polyvinylbutyrate interlayer. This can be caused by the entrapment of air during the manufacturing process or by the ingress of air or moisture after the windscreen has been installed in the vehicle.

Air trapped between the vinyl and glass layers of the windscreen during manufacture usually commences as micro-bubbles that can not be seen during the final inspection. As the glass is subjected to variations in temperature over a period of time the bubbles migrate together to form large areas where the glass and vinyl separate.

The ingress of air or moisture after the glass has been fitted to the vehicle can result from poor installation technique where the urethane has not been properly placed to seal the edge of the windscreen. In such cases air and water can get between the glass and vinyl layers of the windscreen and cause delamination at the edge of the screen. When this process has started it can not be stopped and, sooner or later, there will be large areas of delamination in the windscreen.

There will be different optical effects between the areas where delamination has occurred and the areas where there is no delamination. This could cause driver fatigue and may even result in blind spots where the driver has difficulty in seeing through the screen.

2.1.5 “Milkiness”

Milkiness in a windscreen usually occurs when the polyvinylbutyral layer separates from the layers of glass and starts to return to its original prelaminated state. When this happens the PVB layer starts to become opaque, making it difficult for the driver to see through the screen.

2.1.6 Migration of the Plasticiser

Almost all cars have a dashboard made from a polymeric plastics material. When the vehicle is left out in the sun the plasticiser is liberated from the dashboard and forms a thin film on the inside of the windscreen.

If the inside of the windscreen is not cleaned regularly this film can build up and cause dispersion of the light through the window. This can affect the driver’s vision through distortion of the light from the sun or from the headlights of oncoming vehicles.

2.1.7 Reflections from the Dashboard

Many vehicles have a dashboard that is made from plastic that in certain circumstances of bright sunlight reflects the image from the dashboard onto the windscreen. This reflection can cause distraction to the driver.

The extent of this effect varies with the light intensity and angle as well as the direction in which the vehicle is being driven. While it is not always present it can add to the burden of the driver and affect concentration over an extended period of driving.

A study reported by Schumann, Flannagan, Sivak & Traube (1997) found that dashboard reflectance affected visual performance. Visual performance was found to decrease with higher dashboard reflectance. For example, drivers needed more time to detect objects and they had more misses in detecting low contrast objects.

2.2 STRAY LIGHT

When light travels along a path without disturbance it is called “useful light”. Such light travels from its source without being altered in any way. However, at times this path can be disturbed causing the beam to change in some way after leaving its source. Light that has been disturbed is referred to as “stray light” (see Figure 2). Holtmann, Frischat, & Ruppert (1994) defined stray light as “the amount of light that is not transmitted parallel to the main direction of the incoming light due to scattering at small surface defects such as scratches and impact sites” (p 248). The intensity of stray light depends on the scattering angle and on the intensity of the original beam. Stray light can have a significant negative impact on vision and perception in the driving context¹.

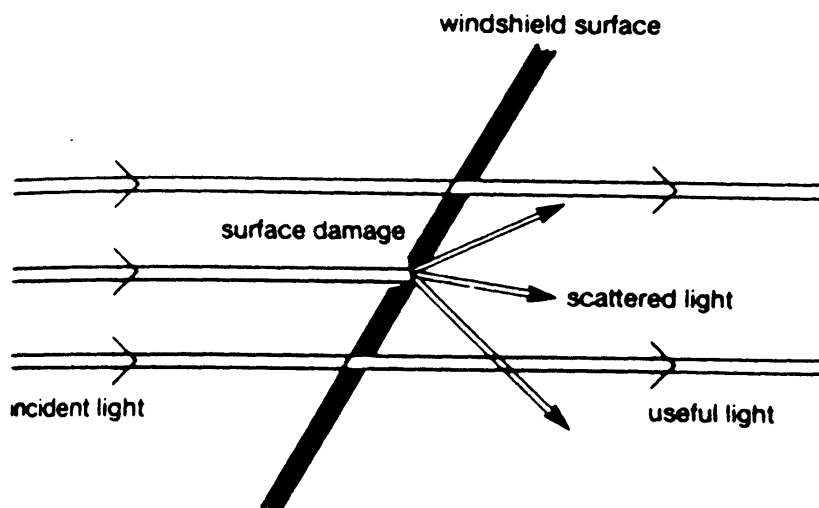

Figure 2 Definition of Terms Relating to Light Travelling Through a Damaged Windscreen (Timmermann, 1985b)

Holtmann, Frischat, & Ruppert (1994) studied the relationship between stray light, impact velocity (of small particles such as sand), impact angle, particle shape and the mechanical properties of the impacting particle and the target material. They concluded that the

¹ Stray light can commonly cause difficulties in any area where undisturbed light is important (eg: when using a photographic camera – a damaged lens may lead to stray light and a distortion or alteration of image).

incidence of stray light could be reduced using glass composed of different materials, to strengthen it against the damage that can lead to the formation of stray light.

2.2.1 The Physics of Stray Light (Kessler, 1991)

Stray light in windscreens can be generated by soiling of glass surfaces and surface defects. Stray light can also be generated by micro-structural defects in the glass itself or in the components of laminated glass.

The scattering of light depends on the relation between the light wavelength and the characteristic parameter of lateral dimension of the scattering object.

If the micro-structural dimensions of the scattering object are large, in comparison with the wavelength of light, i.e. greater than about $1\ \mu\text{m}$, then the scattering of light can be described by means of regular refraction and reflection.

During daylight the eye is adapted to stronger light with many different wavelengths, therefore the impact of stray light is not very severe during daylight. However in cases of suddenly appearing light sources, such as the on-coming headlights of another vehicle at night, the light that hits the windscreen can be deflected into the driver's eye by means of wide-angle light scattering. In this type of situation, a ghost image¹ can appear in the field of view (see Fig 3).

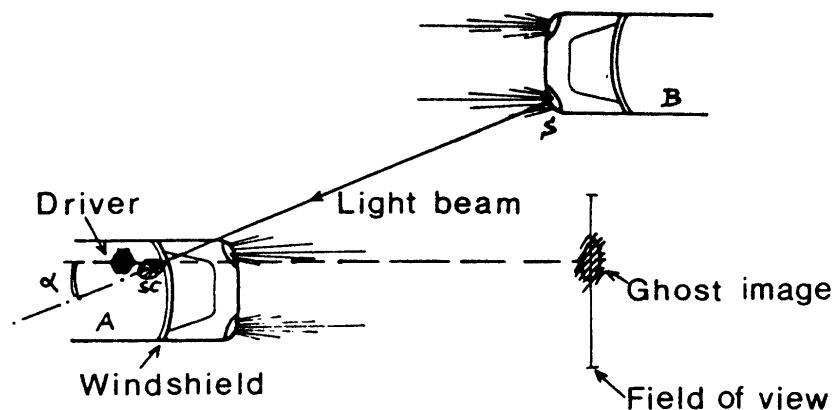

Figure 3 Illustration of the Genesis of a Ghost Image by Wide Angle Light Scattering in a Soiled Windscreen (Kessler, 1991)

2.2.2 Types of Windscreen Damage and Stray Light

Different types of windscreen damage can result in different stray light effects. For example, small chips and craters tend to scatter light with a halo around the light source, while scratches and grooves tend to scatter light perpendicular to the damaged area and add one or two “tails” to the light source (Timmermann, 1985a).

¹ A ghost image is an illusion that may appear to drivers, as a result of scattering light in a windscreen.

Timmermann (1985a)¹ found that light that scatters as a result of deep grooves and scratches, contributes little to the stray light index or reductions in contrast. However as the relative position of the light source moves, these defects will light up suddenly for a short time and can be irritating to drivers and may result in a loss of concentration and alertness.

In the context of driving, light can be scattered as it passes through a windscreen. Kessler (1991) suggested that stray light could be generated by soiling of the glass surfaces, surface defects, microstructural defects in the glass itself or in the components of laminated glass.

The intensity of stray light is dependant on the intensity of the light source and the scattering angle caused by the windscreen damage or soiling (Timmermann, 1985b).

2.2.3 Stray Light and Driving

Dynamic Phenomena

The driving environment is one that is constantly in motion and is a dynamic phenomenon (Kessler, 1991).

Scattered light can change as the light source, vehicle and eyes move relative to one another. Timmermann (1985a) noted that the psycho-physiological effects of this process are not well understood but that it seemed to cause some difficulties for drivers.

SUMMARY

- Windscreens wear and degrade over time
- Exposure to environmental and weather conditions can speed up the degradation process
- Different types of windscreen damage and windscreen soiling can result in different stray light effects
- Small chips form “halo” stray light effects and scratches form “tail” stray light effects
- Damage and the subsequent stray light effects have the potential to degrade visual perception of the traffic environment and compromise safety

2.3 THE LINK BETWEEN WINDSCREEN DEGRADATION AND SAFETY

In this section of the paper, the literature concerning the effects of windscreen degradation and subsequent stray light effects on visual perception and safety will be reviewed.

2.3.1 The Impact on Perception

Kessler (1991) indicated that stray light could have a negative impact on all components of image formation. These were classified into seven groups:

1. Reduction of contrast;

¹ This author did not indicate on what basis they made these statements. The paper suggests that it may be based on some type of measurements however these measurements or experiments have not been discussed or presented here.

2. Distortion of the contour of the visible object through deformation;
3. Misjudgements about the surroundings due to the appearance of “ghost” images;
4. Disturbance of accommodation;
5. Disturbance of adaptation;
6. Blinding through glare; and
7. Disturbance through colour modification.

Kessler (1991) indicated that these disruptions are all the result of dynamic phenomena, as traffic is a procedure in motion.

Timmermann (1985) suggested that it is the ratio of the intensity of the stray light to that of useful light that is important to drivers. He developed a device that measures two stray light indexes (SLI). He suggested that minimum SLI values (which cause a reduction in the power of perception) could be determined in the laboratory.

Timmermann (1985b) found that worn windscreens can have a negative effect as they cause an increase in re-adaptation time after “dazzling” and also accelerated reduction in concentration.

Derkum (1991) stated that worn windscreens can show appreciable scattering of light and this is particularly apparent at night with approaching oncoming vehicles. The elderly driver or those with visual problems may be particularly susceptible to the resulting roadway vision impairments (Sivak & Olson, 1982, from Hartley, Lamble & Penna, 1995).

In their book titled *Forensic Aspects of Vision and Highway Safety* Allen, Abrams, Ginsburg, & Weintraub (1996) discussed the three principal types of glare (which can be a type of stray light effect):

- **Sensory overload** Begins to occur once a certain luminance level is exceeded (1,000 foot lamberts). Between 7,000 and 10,000 foot lamberts, tearing and eye spasms occur and visual performance fails.
- **Optical image degradation** Veiling glare can occur via a uniform film of light scattered across the retina from a single bright glare source. Multiple glare sources cause a veiling glare which reduces the contrast in the retinal image and reduces visual performance (even as low as zero). The image degradation is known to be worsened by pathology, refractive errors and age and it can be incapacitating.
- **Psychological annoyance (discomfort glare)** This type of glare usually occurs for example, when heading towards the setting sun. The increasing sky brightness becomes uncomfortable.

Each of these types of glare results in reduced visual performance.

The next section of this report will review the field and laboratory studies examining the link between windscreen degradation, stray light and visual perception.

SUMMARY

- Stray light can have a negative impact on all components of image formation
- The ratio of stray light to useful light seems to be important
- Worn windscreens can “dazzle” drivers
- Different types of glare (an effect of stray light) seem to have different effects on visual perception

2.3.2 Field and Laboratory Studies

A major literature review was conducted by Sayer and Traube (1994). This paper reviewed factors that influence visibility and privacy through windscreens. The relevant articles that were reviewed in this article are discussed in this chapter.

Adaptation After Glare

Timmermann (1985a) conducted a number of laboratory tests “to determine which minimum Stray Light Index (SLI) values will cause a noticeable reduction in the power of perception in the laboratory” (p 338). He did this by measuring:

- a) the times of re-adaptation after “dazzling”; and
- b) the distances at which objects are recognised using a road simulator¹.

Following the re-adaptation experiment it was found that subjects took longer to re-adapt following the “dazzling” looking through a worn windscreen compared with looking through a new windscreen and that this resulted in accelerated reductions in concentration.

In the second experiment subjects were required to look through a windscreen (worn and new) with a glare source and indicate when they detected an approaching object (this simulated pedestrians crossing the road at night without streetlights in conjunction with on-coming headlights). It was found that the detection distance was reduced by 7% through the worn windscreen compared with the new windscreen.

Problems were identified in windscreens with a mean SLI of 1.1 (re-adaptation experiment) and 1.7 (detection distance experiment).

The “Mandelbaum Effect”

Mandelbaum (1960, as cited in Chauhan & Charman, 1998) conducted a study that found that it was sometimes impossible to focus on distant objects (buildings) when viewing them through a wire mesh window screen. He found that the screen had to be a particular distance from the eyes to cause this effect, and that when the screen was closer or further away (from this point), the buildings could be re-focused. This phenomenon is a type of accommodation problem and has been labelled the “Mandelbaum Effect”. Chauhan and Charman (1998) conducted a static field study² to determine whether the car windscreen could act as an alternative accommodation stimulus to targets on the road ahead, causing the eye to accommodate inappropriately. Results of this study suggested that it is unlikely that the Mandelbaum effect would occur under night time driving conditions. The authors concluded that this effect be further explored by continuously measuring accommodation behaviour in a moving vehicle with a larger number of subjects, particularly those with high dark focus values (taking longer to focus in dark conditions).

Simulation Studies

A study conducted by Hartley, Lamble & Penna (1995) used an electronic driving simulator to collect a range of physiological, vehicle handling and subsidiary data from

¹ It should be noted however that these experiments were conducted using small samples (experiment 1, N=13 and experiment 2, N=20) and no details of the sample used were reported (e.g.: visual problems etc). Results should be considered with caution.

² These authors conducted static field tests using clear, rain covered, and damaged (small scratches) windscreens at different lighting levels. The authors did not describe their sample in terms of visual abilities etc.

subjects (N = 31) driving along a 100km stretch of road. The experiment was conducted with both degraded and non-degraded windscreens. The authors did not quantify the type or extent of degradation or soiling to the degraded windscreen. They stated that the degraded windscreen was “degraded using light sandblasting to produce a pitted, abraded surface consistent with the quality of a windscreen that would be placed by Windscreen O’Brien” (p 22). They also stated that both surfaces of the degraded windscreen were then wiped with a damp cloth to “leave smear marks on both surfaces consistent with those normally found on dirty car windscreens” (p 23). Results indicated that driving with a degraded windscreen:

- caused drivers to crash twice as often as when driving with a new windscreen;
- slowed their reaction times to a secondary task; and
- had no significant effect on vehicle handling or on the physiological measures considered.

The authors concluded that driving with a visually degraded windscreen induces fatigue and performance decline more quickly than when driving with a non-degraded windscreen.

Age Effects

Allen (1974) conducted static and dynamic experiments examining the impact on vision of windscreen dirt and surface damage. This author found that there was a reduced visual range through the windscreen at night when facing headlight glare. Allen concluded that “a damaged windscreen can make a young driver behave visually like a much older driver, while an older driver with a newer windscreen may see better than a younger driver viewing through a damaged windscreen” (p 17)¹. He had difficulty drawing any conclusions regarding detection distances on the roadway as the speed used in his studies (zero in the static test and slow speed in the dynamic test) gave superior detectability of roadside objects compared with that experienced in real life.

It is difficult to generalise about the relationship between windshield dirt or scratches and age from this study as little information is provided about the type and extent of the damage of the windscreens examined. Further to this, the visual abilities of all subjects (including whether they wear glasses) would be an important variable to consider rather than age per se.

Owens, Sivak, Helmers, Sato, Battle, & Traube (1992) included age as a factor in their experiment looking at the effect of transmittance and light scatter in windscreens. In the glare situation (oncoming glare created using a slide projector) older subjects found the oncoming glare more debilitating. They indicated that older drivers may suffer from intraocular light scatter. They suggested that this could result in older drivers suffering difficulties with clean windscreens that younger drivers would experience only with dirty windscreens.

Night Driving and Detection Distances

Haase, Schneider & Timmermann (1989) reported results of experimental work conducted by Helmers (1987) that showed that the “contrast of objects on the road can be greatly reduced by the stray light caused by a worn windshield, because the scattered light from the windshield generates a “veiling” luminance” (p 34). A consequence of contrast reduction can be an associated reduction of visibility distance.

¹ This author did not describe the subjects who took part in this study or present any type of age based results.

Lundkvist and Helmers (1993)¹ carried out an experiment to measure the detection distances to objects on the road when viewed through windscreens in varying states of wear. The results showed that detection distances to an object on the road when viewed through a very worn windscreen (not quantified) can be 15% greater than when viewed through a new windscreen. Further, if a driver has impaired visual acuity (of 0.5) the detection distance will be reduced by 15-20%. A very worn windscreen in combination with impaired visual acuity may result in a loss of detection distance of up to 20 metres.

These authors estimated that approximately 5% of the vehicle fleet may have a windscreen that is worn even more than that which resulted in a 15% reduction in detection distance and scarcely 5% of drivers are estimated to have a visual acuity of less than 0.5. The authors postulated that this situation could lead to many nighttime crashes.

Owens, et al. (1992)² conducted a laboratory study investigating the effects of various factors on night vision. The factors considered as part of this study were rake angle, tinting, light scatter, target contrast, glare, age and night myopia (with rake angle and tinting being their primary factors of interest). Their results indicated that light scatter due to dirt and wear can dramatically impair nighttime visibility.

Haase, Schneider & Timmermann (1989) proposed a method for estimating the percentage of night time accidents that are related to windscreen wear. They suggested that samples of day and night crashes be compared in order to reduce the influence of other factors in the measurements. They indicated that they had commenced a pilot study. However no detail has been provided on the method employed.

Effects of Scattered Light (Rompe & Engel, 1984)

This study examined the influence of scattered light in windscreens on driver's vision during night driving using a driving simulator³. Both object detection distances and reaction times were used as measures of the impact of scattered light in the windscreens with different haze levels (clear, 0.2%, 1.5%, and 4.9%). Results indicated that on average, the percentage of correct answers decrease with an increase in haze (from 91% correct with a clear windscreen to 73% with a 4.9% haze windscreen). Interestingly, it was found that subjects adapted their speed to their abilities and those with the best visual performance drove the fastest.

A Study in Progress

In the United Kingdom, ICE Ergonomics are presently conducting a study on behalf of the Department of the Environment, Transport and the Regions (DETR). They are investigating the effects on a driver's/rider's quality of vision whilst viewing the road scene through windscreens or helmet visors of reduced luminous transmittance due to tinting. Additionally, they are examining the combination effects of abrasion, haze and dirt on the surface of windscreens and visors and the impact of 'A' pillar width.

This study will employ a structured series of trials. Subjects representative of drivers and riders, will be used to quantify the effects of tinting, haze, abrasion, and 'A' pillar design

¹ This report is in Swedish but also includes an English summary. The information here has been drawn from the summary and from the short magazine article by Helmers & Lundkvist (1989).

² These authors did not quantify the level of wear for these windscreens but did describe the soiling in detail. They also considered subjects age and visual abilities.

³ There were 20 subjects included in this study.

on the driver/rider's ability to see critical features on the road ahead (under a representative range of real-world environmental, lighting and task conditions). This will then enable their effects on road safety (accident probability) to be established.

SUMMARY

- There is considerable evidence to suggest that windscreen damage that results in the formation of stray light effects may have a negative impact upon driver's visual perception.
- A number of field and laboratory studies have been conducted examining the link between windscreen degradation and perception.

The key findings from this research relating to stray light effects on driver perception suggest that:

- Drivers may take longer to re-adapt their vision following exposure to the stray light ("dazzling") effects created through a worn windscreen;
- Detection distances to objects on the road ahead may be reduced when looking through worn windscreens with stray light effects. Further, the contrast of objects on the road ahead may be reduced by stray light and a consequence of this could be a reduction of visibility distances;
- While detection distances may be reduced when driving with a worn windscreen, drivers seem to adapt their speed to their abilities. One study found that those with the best visual performances drove the fastest;
- Drivers did seem to be able to view objects at a distance when looking through a worn windscreen despite previous research suggesting that this could be a problem (the "Mandelbaum" effect);
- Dirty windscreens seemed to cause drivers to crash twice as often in a driving simulator (as compared to driving with a new windscreen) and when driving with a degraded windscreen, drivers reactions times to a secondary task may be slowed. The authors of this study concluded that driving with a visually degraded windscreen induces fatigue and performance declines more quickly than when driving with a non-degraded windscreen;
- Older participants may find stray light effects ("glare") to be more debilitating compared with the younger participants.
- While some of these studies may have methodological weaknesses, the overall findings of research in this area suggest that the stray light effects that result from worn windscreens may have a negative effect on driver perception.
- A study is currently being conducted in the United Kingdom and it will be interesting to examine these results when they are released in light of the present project.
- It is important to note that the studies reviewed that examine the link between windscreen degradation and visual perception have not compared the differential effects of different categories of windscreen damage (ie: cracks and bullseyes versus haze). Information on this issue is important in developing criteria for determining whether or not to replace damaged windscreens.

2.3.3 The Crash Link

An extensive review of the literature resulted in the discovery that very few studies have attempted to quantitatively establish a link between windscreen degradation and crash involvement. Commonly, crashes are the result of multiple causal factors and examining the link between windscreen damage or wear and crash involvement is not an easy task. This may at least partly explain the dearth of literature in this area.

The simulation study conducted by Hartley, Lamble & Penna (1995) (and reported earlier) reported that degraded windscreens seemed to cause drivers to crash twice as often as compared to when driving with a new windscreen. It should be noted that this was a fairly small study (N = 31) with a number of limitations, so results should be considered with caution.

In their paper reviewing studies that examined the link between visibility from motor vehicles and crashes, Henderson, Smith, Burger & Stern (1983) noted that there had been very little attention paid to the issue of direct visibility in the various research and analytic studies that had been conducted over the previous decade. They suggested that instead there has been a greater focus on examining indirect visibility such as using mirror, periscopes, electronic and infrared devices. They also noted:

“To date, none of the research projects has involved large fleets of vehicles or used actual accident involvement as an evaluation criterion. Instead, relatively small numbers of vehicles and subjects have been used to obtain relatively large numbers of observations on such proxies for accident involvement as frequency and duration of mirror glance and direct looks while performing specified manoeuvres in traffic” (p 95).

The “Tri-Level” study performed by Treat (1980, as cited by Green & Burgess, 1981 and Henderson, et. al., 1983) for the Institute for Research in Public Safety included an examination of “Vehicle Factors” associated with crash involvement¹. Vehicle visibility related causes of crashes were considered as part of this study and included “cases where front, side or rear windows were obscured by dirt, decals, or physical defects” (p 97 Henderson et.al., 1983). “Windscreen obstructions due to ice, frost, water, etc on windows were the primary vehicle-related vision obstruction (Treat, 1980, p 16, as cited by Green and Burgess, 1981). Windscreen damage was not implicated as a factor in this study. Visibility-related causes were found to account at a “certain probable level of confidence” for only 1.4% of all crashes investigated. Henderson et. al. (1983) noted limitations with this study (e.g. the researchers did not consider vehicle structural components may have played a role) and they questioned the finding that attributed nearly all accidents to human error.

The Road and Traffic Authority (RTA) in New South Wales recently conducted a large crashed vehicle study (Holgate, Harkness, & Vertsonis, 1999). While the full report has not yet been released, the authors have indicated that they have conducted detailed examinations of approximately 4000 cars (involved in approximately 2500 crashes). Data relating to the condition of vehicle windscreens was collected as part of this project. In the future, the possibility of working in collaboration with the RTA, analysing this data in light of the present project, could be explored.

¹ This study investigated and analysed crashes occurring in Monroe County, Indiana, United States of America.

SUMMARY

- There is little evidence to suggest that there is a link between windscreen degradation and crash risk.
- Generally there seem to have been no properly controlled studies that have investigated the relationship between windscreen degradation and crash involvement.
- One (simulation) study reported an increased crash rate when driving with a worn windscreen. The only other study identified that has attempted to investigate this issue has yielded data suggesting that windscreen degradation and soiling contribute minimally to crash involvement, although as noted previously, there is some doubt as to the scientific robustness of this study.
- Clearly there is a need for research examining the link between windscreen degradation and crash risk. Data has been collected by the RTA as part of a vehicle crash study in New South Wales and it may be possible in the future to explore the issue of analysing this data in light of the present project.

3 REGULATIONS AND GUIDELINES FOR WINDSCREEN INTEGRITY

Vehicle safety requirements in Australia are specified at a number of levels. These levels are:

1. The Motor Vehicle Standards Act 1989;
2. Australian Design Rules (endorsed as national standards by determinations made pursuant to Section 7 of the Motor Vehicle Standards Act 1989);
3. Australian Vehicle Standards Rules 1999 (AVSRs)¹;
4. Roadworthiness Guidelines; and
5. Administrative Guidelines: Assessment of Defective Vehicles.

The relevant sections² of each of these levels of assessment will be summarised and discussed briefly, in the context of windscreen visibility, structural strength and safety. Further, relevant documents that have been identified overseas will also be included in this review.

3.1 THE MOTOR VEHICLE STANDARDS ACT 1989

The Motor Vehicle Standards Act 1989 was prepared by the Office of Legislative Drafting, the Attorney-General's Department in Canberra. This Act was recently reviewed by the federal government and the report can be viewed at <http://www.dotrs.gov.au/land/vehicle/review/review.htm>.

The object of the Act is to ensure uniform vehicle standards that are applicable to all road vehicles that are used in the transportation system in Australia.

Essentially the Motor Vehicle Standards Act is the overall governing national guideline relating to vehicle safety in Australia. The other guidelines and standards follow from and meet the requirements of this³.

3.2 AUSTRALIAN DESIGN RULES FOR MOTOR VEHICLES AND TRAILERS (3RD EDITION)

The Australian Design Rules (ADRs) are national standards that cover new vehicles to the market. The Australian Design Rules for Motor Vehicles and Trailers (3rd Edition) forms part of the National Standards determined under section 7 of the Motor Vehicle Standards Act (current Act was passed in 1989).

¹ ASVRs were approved by the Australian Transport Council in January 1999 and are implemented in each jurisdiction's legislation/regulations.

² Text has been drawn from this document verbatim in order to ensure that it is presented correctly.

³ It should be noted that these guidelines and standards usually take precedence in an hierarchical order (for example a requirement of a Standard would take precedence over a requirement in a roadworthy guideline). However there are some exceptions. For example, there are situations where the requirements of the AVSRs are different from those of the ADRs and where the AVSRs apply instead of ADR requirements (Barry Hendry, National Road Transport Commission, Personal Communication).

The rules are endorsed by the Australian Transport Council (ATC) which is comprised of Federal, State and Territory governments. New Zealand has observatory status. This standard uses United Nations categories and is now harmonised to a large extent with international standards.

The Australian Design Rules set out the design standards for vehicle safety. All cars that are first supplied to the Australian market are required to comply with these. This includes vehicles manufactured in Australia as well as those imported from overseas.

3.2.1 Australian Design Rule 8/00 Safety Glazing Material

Australian Design Rule 8, Safety Glazing Material governs the material used in vehicle glazing (including windscreens).

ADR 8/00 indicates the original version of ADR 8. This document has been revised however since it's inception and ADR 8/01 indicates the first revised version of this rule. Amendments increase the stringency of the rule for vehicles to which this rule already applies.

Purpose and Scope

“This Australian Design Rule (ADR) is part of the Australian motor vehicle standards system and is a national standard for the purpose of the Motor Vehicle Standards Act 1989.

The function of this Australian Design Rule is to specify the performance requirements of material used for external or internal glazing in motor vehicles which will ensure adequate visibility under normal operating conditions, will minimise obscuration when shattered, and will minimise the likelihood of serious injury if a person comes in contact with the broken glazing material” (p 1).

This ADR is applicable to the design and construction of a range of vehicles including passenger cars, light vehicles and heavy vehicles (manufactured on or after 1st July 1988). A newer version, the Australian Design Rule 8/01, was first approved by the Minister for Transport and Communications on September 1993 in Motor Vehicle Standards Determination No. 2 of 1993. The final and current version of the Australian Design Rule 8/01 was first approved as a national standard on 30 November 1995. The current Design Rule (8/01) differs from the previous version (8/00) by,

- Mandating laminated safety glass in the windscreen of all vehicles,
- Specifying primary vision areas for vehicles other than passenger cars,
- Deleting an obsolete edition of the Australian Standard, and
- Deleting an obsolete edition of the JIS Standard.

3.3 AUSTRALIAN / NEW ZEALAND STANDARDS¹

The aim of the Australian Vehicle Standards Rules (AVSRs) standards is to regulate the industry of concern to maintain a minimum level of safety. The AVSRs are the “in-service” vehicle standards. The AVSRs fall under the Road Transport Reform (Vehicles

¹ These were developed by Standards Australia and Standards New Zealand. Further, the ADRs refer to these as Referenced Standards and the AVSRs refer to these as Adopted Standards.

and Traffic) Act 1993. The Motor Vehicle Standards Act 1989 states that vehicle standards are designed to:

- (a) make road vehicles safe to use; or
- (b) control the emission of gas, particles or noise from road vehicles; or
- (c) secure road vehicles against theft; or
- (d) promote the saving of energy.

Of relevance to the present project, in-service vehicle standards generally aim to ensure that the safety level of the fleet of vehicles on the road is maintained to the minimum level as required by the ADRs.

The aim of this section is to look at various windscreen standards (from Australia and overseas) and explore how they address the issues of windscreen damage / degradation or reduced windscreen structural strength.

There are two main Australian / New Zealand standards that are of relevance to this project:

- AS/NZS 2080: 1995 Safety glass for land vehicles;
- AS/NZS 2366.1: 1999 Windscreen repairs. Part 1: Repair procedures; and
- AS/NZS 2366.2: 1999 Windscreen repairs. Part 2: Repair systems

These will be summarised and discussed briefly.

3.3.1 AS/NZS 2080: 1995 Safety glass for land vehicles

The relevant sections of this Standard are presented below.

Section 1 Scope and General

1.5 Location of Primary Vision Area of Windscreens

When assessing windscreens the location of the primary vision area for drivers is important to consider. This is the area that is believed to be most relevant for drivers' vision. In this Standard this area has been defined as,

1.5.1 Passenger vehicles

“The boundaries of the primary vision area of windscreens for road vehicles shall be in accordance with the vehicle manufacturers' specification. If this information is not available, the boundaries for a primary vision area shall be 90mm from the top and side edges and 65mm from the bottom edge of the body aperture when viewed from the inside of the vehicle.”

1.5.2 Commercial vehicles (including forward control vehicles – see Figure 4)

“The boundaries of the primary vision area of windscreen for road vehicles shall be in accordance with the vehicle manufacturer's specification. If this information is not available, then –

- (a) *the boundaries for a primary vision area shall be in accordance with Clause 1.5.1; or*
- (b) *the boundaries of the primary vision area shall be in accordance with Figure 1. With the top of the seat undepressed and in the upper position –*

- (i) *the lower boundary shall be the higher of the top of the undepressed seat or 65mm above the bottom edge of the body aperture when viewed from the inside of the vehicle; and*
- (ii) *the side boundaries shall be 90mm from the side edges of the body aperture when viewed from the inside of the vehicle.”*

1.5.3 *Other vehicles* “The boundaries of primary vision area shall be as specified by the purchaser or the vehicle manufacturer.”

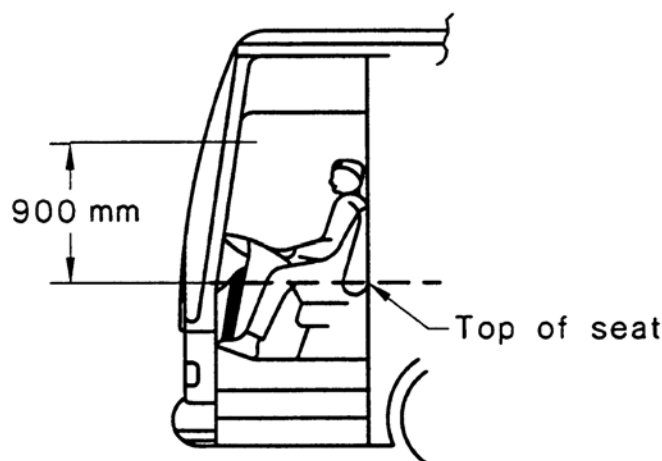

Figure 4 Primary Vision Area for Commercial Vehicles

1.6 General Requirements,

“The safety glass shall -

- (a) *be free from cracks, scratches, bubbles, blisters and other defects that would interfere with vision, appearance or service (see Note); and*
- (b) *have surfaces resistant to abrasion and to the effects of exposure to the atmosphere.*

NOTE: The production of small indentations in heat-treated safety glass within 12mm of the edge of the glass is an inherent feature in most processes used at present in the manufacture of glass. Any such indentations extending from the surface towards the interior of the glass, or any surface vent extending 1mm in length, are not permissible.”

3.3.2 AS/NZS 2366.1: 1999 Windscreen repairs. Part 1: Repair procedures

The 2366 Standard was prepared by the Joint Standards Australia/Standards New Zealand Committee ME/55, Safety Glass for Land Transport, to supersede AS 2366-1990 (in part) and NZS 5470:1993 (in part). The Federal Chamber of Automotive Industries (FCAI) did not support the publication of this Standard as they believed that windscreens should not be repaired.

The Standard has been prepared to assist windscreen repairers in their decision to repair a damaged laminated windscreen. It nominates the procedures and specifies limits for a successful repair. It is not intended that it be applied to determine the roadworthiness of a motor vehicle although repairing to the Standard might extend the life of a damaged windscreen.

Section 1 Scope

This Standard specifies requirements for the repair of cracks, “bullseyes”, and similar damage on laminated safety glass windscreens of road vehicles, other than the repair of scratches and sandblasting.

Section 2 Application

The Standard applies to the repair of laminated safety glass windscreens that comply with AS/NZS 2080 or ADR 8 or NZLTR 32012, by filling and gluing the cracks and depressions with windscreen repair material in order to minimise the loss of optical clarity and mechanical properties of the damaged area on the windscreen, using repair systems complying with AS/NZS 2366.2.

Section 5 Damage Types and Dimensions

5.1 General

For the purpose of this Standard, laminated glass windscreen damage is categorised into five fundamental characteristics referred to as a crack, a star, a bullseye, a crater and a horseshoe. The damage may consist of a single or multiple incidences of these characteristics.

5.2 Crack damage

A crack is a line fracture through a single layer of glass. The size of the damage shall be measured as the diameter of the smallest circle fully encompassing the crack unless the resulting diameter is greater than 100mm, in which case the size of the damage shall be the length of the crack measured along its path.

5.3 Star damage

Star damage is a series of line fractures radiating outwards from a point of impact. The size of the damage to a single layer of glass shall be measured as the diameter of the smallest circle fully encompassing the star.

5.4 Bullseye damage

Bullseye damage is a damage that results in an approximately conical section of glass being separated from the interior surface of a single layer of glass. The interior surface is that adjacent to the laminate bonding layer. The size of the damage shall be measured as the smallest circle fully encompassing the bullseye.

5.6 Crater damage

Crater damage is a damage that results in an approximately conical section of glass being separated from the exterior surface of a single layer of glass. The size of the damage shall be measured as the smallest circle fully encompassing the crater.

5.7 Horseshoe damage

Horseshoe damage is damage that results in an approximately semicircular shape extending from the exterior surface and increasing in radius until it reaches the interior surface of a single layer of glass. The size of the damage shall be measured as the smallest circle fully encompassing the horseshoe.

Section 6 Influencing Environmental Factors

6.1.1 General

The quality of windscreen repairs can be affected by certain environmental factors which shall be considered prior to the commencement of a repair. The level of success of the repair will depend on the cleanness of the damaged area and the conditions prevalent at the time of repair.

If there is any water contamination or dirt contamination or if the recommendation of the repair material manufacturer with regards to temperature conditions are not followed the repair may not be successful.

Section 8 Inspection and Quality of Repair

A repair shall comply with the following quality requirements:

- (a) A repair in the wiped area of the windscreen shall not reduce the effectiveness of the wiper blades.
- (b) If, when inspected from the driver's seating position, a residual small dull spot is to be seen in the repaired area, this spot shall not exceed 5mm in diameter if fully located outside the critical vision area, or 2mm in diameter if fully or partly located inside the critical vision area.
- (c) Windscreen repair material shall be used in accordance with the manufacturer's instructions.

3.3.3 AS/NZS 2366.2: 1999 Windscreen repairs. Part 2: Repair systems

Section 1 Scope

This Standard specifies performance requirements for windscreen repair systems, including the materials used, to be employed for the repair of laminated safety glass windscreens that have been damaged.

Section 2 Application

The Standard applies to the repair of laminated safety glass windscreens that comply with AS/NZS 2080 or ADR 8 or NZLTR 32012, by filling or gluing the cracks and depressions with windscreen repair material in order to minimise the loss of optical clarity and mechanical properties of the damaged area on the windscreen, using repair procedures complying with AS/NZS 2366.1.

Section 5 Principal Characteristics of a Windscreen Repair System

5.1 General

A windscreen repair system shall be identified by the principal characteristics listed in Clause 5.2. A change in any principal characteristic shall imply a new system.

5.2 Characteristics

The principal characteristics of a windscreen repair system shall be as follows:

- (a) The apparatus used for repair.
- (b) The chemical composition of the repair material.
- (c) The trade name or mark of the manufacturer of the repair system.
- (d) The category of damage which can be repaired by the system (Refer to Clause 6).
- (e) The repair method and procedure specified by the manufacturer.

Section 6 Categories of Damage

The categories of damage that can be repaired by a windscreen repair system shall be classified as follows:

- (a) Category A Star damage up to 30mm in diameter.
Cracks which fit within a 100mm diameter circle.
- (b) Category B Bullseye damage up to 20mm in diameter.
Horseshoe damage up to 25mm in diameter.
Crater damage up to 5mm in diameter.
- (c) Category C Cracks with length L not exceeding 350mm when measured according to Part 1, Clause 5.2, and which cannot be enclosed within a 100mm diameter circle.

3.4 OVERSEAS STANDARDS

A number of overseas windscreen standards have been identified and will be summarised and discussed briefly.

3.4.1 United Nations – European Standard. Uniform Provisions Concerning the Approval of Safety Glazing and Glazing Material – United Nations Agreement Concerning the Adoption of Uniform Conditions of Approval and Reciprocal Recognition of Approval for Motor Vehicle Equipment and Parts, Addendum 42: Regulation No. 43

This document discusses tests of windscreen resistance to abrasion.

Ordinary Laminated-Glass Windscreens – Annex 6

5.1.2 “The safety-glass pane shall be considered satisfactory with respect to abrasion resistance if the light scatter as a result of abrasion of the test piece does not exceed 2 per cent.”

Glass-Plastic Windscreens – Annex 10

With respect to the test of resistance to abrasion to the outer face,

5.1.1.1. “The safety-glass pane shall be considered satisfactory with respect to abrasion resistance if the light scatter as a result of abrasion of the test piece does not exceed 2 per cent.”

3.4.2 ANSI/SAE Z26.1-1996. American National Standard for Safety Glazing Materials for Glazing Motor Vehicles and Motor Vehicle Equipment Operating on Land Highways – Safety Standard

This standard was approved by the American National Standards Institute on 11th August 1997 and is a revision of ANSI/SAE Z26.1 – 1990. The use of American National Standards is completely voluntary.

This standard outlines a set of procedures and performance requirements for glazing materials. A fundamental purpose of this standard is to “*prescribe the functional properties of safety glazing materials in such a manner that they can be used in any place in motor vehicles and motor vehicle equipment for which they possess those mechanical and optical properties or both, that are requisite or appropriate*” (p i).

This standard is designed to serve two purposes:

1. *To afford a basis for standards for adoption in regulations by governmental regulatory bodies; or*
2. *For use by motor vehicle commissioners or others as reference standards in such cases as they may have discretionary authority to adopt these or other standards in connection with the approval of safety glazing materials or other items of use in or on motor vehicle equipment.*

Seven types of safety glazing can meet the requirements detailed in this standard.

1. Laminated glass
2. Glass-plastic glazing material
3. Tempered glass
4. Plastic
5. Multiple glazed unit
6. Bullet-resistant glazing
7. Bullet resistant shield

Scope

“Specifications and methods of test for safety glazing material (glazing material designed to promote safety and reduce or minimise the likelihood of personal injury from flying glazing material when the glazing material is broken) as used for windshields, windows, and partitions of land and marine vehicles and aircraft” (p i).

As indicated above, the safety focus of this standard relates to the shattering (and consequences of this) of the material. However a number of the safety tests presented are of relevance to the present project.

The purpose of the tests described in this standard are to determine whether a safety glazing material is has certain desirable and obtainable qualities for its acceptance under this standard. The below test appear to have relevance to the present project:

- | | |
|------|---|
| 5.15 | <i>Optical Deviation and Visibility Distortion, Test 15</i> |
| 5.17 | <i>Abrasion Resistance, Test 17 (Plastics)</i> |
| 5.18 | <i>Abrasion Resistance, Test 18 (Safety Glazing Material)</i> |

3.4.3 American Standard. Standard Test Method for Haze and Luminous Transmittance of Transparent Plastics – 1977

The aim of the standard is as follows,

“This method covers the measurement of the light-transmitting properties, and from these, the light scattering properties, of planar sections of transparent plastics”.

This standard defines haze as,

“-that percentage of transmitted light which in passing through the specimen deviates from the incident beam by forward scattering. For the purpose of this method only light flux deviating more than 2.5 degrees on the average is considered to be haze.”

3.4.4 German Standard. Road Vehicles – Measurement of scattered light of safety glazing materials for vehicle glazing. Part 1: Annular diaphragm method (DIN 52298-1, December 1998)

This standard appears to be one of only a few international standards that deals specifically with the issue of haze or scattered light and how to measure it. It describes the annular diaphragm method for measuring scattered light. It can be used for flat or curved shields used for vehicle glazing, and can also be used for vehicle windscreens “in the assembled state”.

The scope of this standard is as follows:

“The annular diaphragm method according to this standard can be used for the measuring of the scattered light of the safety shield to be tested at small angles to the optical axis (direction of transmission). The measuring geometry takes into consideration the visual conditions of the driver of the vehicle, e.g. in opposing light or during night road traffic, when objects in one’s own lane have to be recognised in good time while looking into the headlight of opposite coming vehicles. In this situation the recognisability of the objects may be reduced by scattered light emanating from the safety glass shield”.

This standard defines scattered light as follows:

“When directed light passes through a shield, a portion may be deflected by surface structures (defective polishing, damages like scratches, scoring and tiny dimples, dirt, dust particles)...This light, passing through in an irregular manner, is designated as scattered light”.

Scattered light is measured using the reduced luminance coefficient, which is discussed further in a later section (4). Details of the procedures for measuring scattered light appear in section 4.3.

3.4.5 JIS R 3211: 1998. Japanese Industrial Standard. Safety Glazing Materials for Road Vehicles.

This Japanese standard was first established on 1st July 1979 and was revised on 20th of April 1998.

Scope

This Japanese Industrial Standard specifies the safety glazing materials to be used mainly for the windows of road vehicles (referred to as safety glass)¹.

4.7 Abrasion Resistance

The abrasion resistance of the laminated glass, organic glass and glass-plastics shall satisfy the haze values as shown in Table 1,

¹ This includes windscreens.

Table 1 Haze value due to abrasion

	Haze value due to abrasion			
	Testing region 1		Testing region 2	
	Outside of vehicle	Inside of vehicle	Outside of vehicle	Inside of vehicle
Laminated glass A	2% max.	-	2% max.	-
Laminated glass B				
Organic glass	4% max.		15% max.	
Glass-plastic	2% max.	4% max.		

NB: The testing regions relate to different areas of glass as specified in JIS R 3212.

Guidelines are also offered for optical distortion in the following section.

4.12 Optical Distortion.

This document states that the optical distortion of safety glass shall satisfy Table 2 (below).

Table 2 Maximum permissible Values of Optical Distortion

Type	Category of road vehicles	Test region		Maximum permissible value of optical distortion
		Front window	Side window	
Laminated glass A	M ₁	A or a	-	2
Laminated glass B		B or b	D	6
Zone-toughened glass	Other than M ₁	I or a	-	2
Organic glass		-	E	6
Glass-plastics				

3.4.6 JIS R 3212: 1998. Japanese Industrial Standard. Test Method of Safety Glazing Materials for Road Vehicles.

Scope

This Japanese Industrial Standard mainly specifies the test methods of safety glazing materials for road vehicles (referred to as safety glass). The following tests appear to have relevance to the present project.

3.7 Abrasion resistance test

3.12 Optical distortion test

3.4.7 BS AU 242: 1991. British Standard. Automotive Windscreen Repair.

Scope

This British Standard gives recommended practices regarding the repair of laminated windscreen that have been damaged by impacts. It applies to heavy goods vehicles, coaches and passenger cars. It makes recommendations governing:

- a) the type and size of damage which may be repaired;
- b) the area on the windscreen in which a repair may be made;
- c) the procedures to be followed by the repairer;
- d) the steps necessary to assess the quality of the completed repair;
- e) the reports and records to be completed by the repairer.

General

The type and size of damage which may be repaired is limited as a function of its position on the windscreen (refer to Figure 5).

ZONE A No repairs permitted

ZONE B Damage which is contained within a circle of 15mm diameter

ZONE C Damage which is contained within a circle of 25mm diameter

ZONE D Damage which is contained within a circle of 40mm diameter

Within ZONES B, C, and D no two repairs should be closer than 100mm

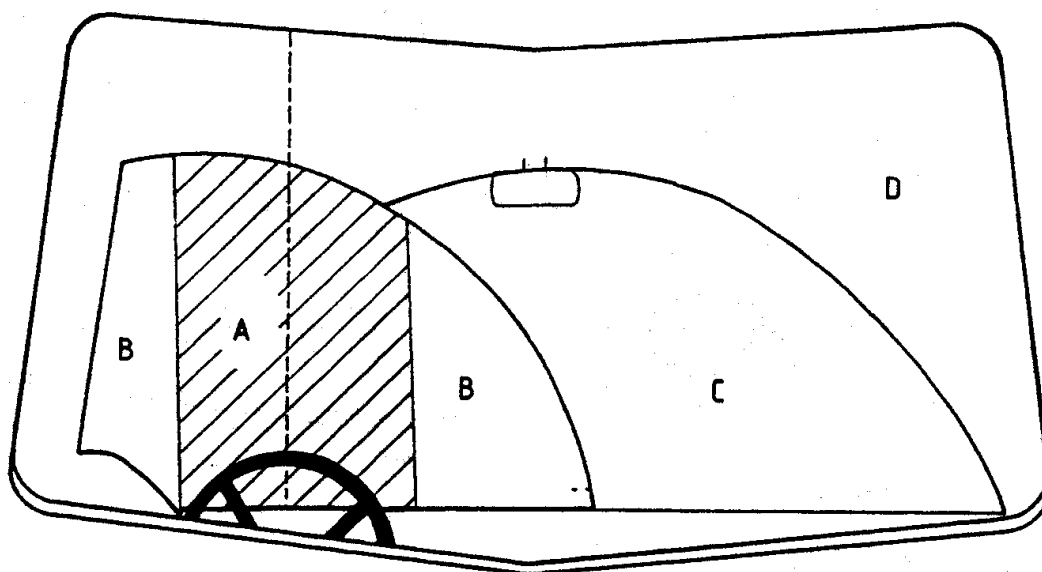

Figure 5 Areas of windscreen zones for permitted repair

Type, size and conditions of damage

The following restrictions regarding the type and size of damage should be observed:

- a) repairs of damaged areas on windscreen should be as above (and shown in Figure 5);
- b) no repair of damage, which extends through all layers of glass should be conducted in any area of windscreen;

- c) no repairs of damage with the crater at the point of impact exceeding 5mm in diameter should be conducted;
- d) no repair should be undertaken when noticeable damage, delamination or irreversible contamination of the interlayer has occurred within the damaged area.

This standard also illustrates the various types of damage that may be identified for repair under this standard (Figure 6).

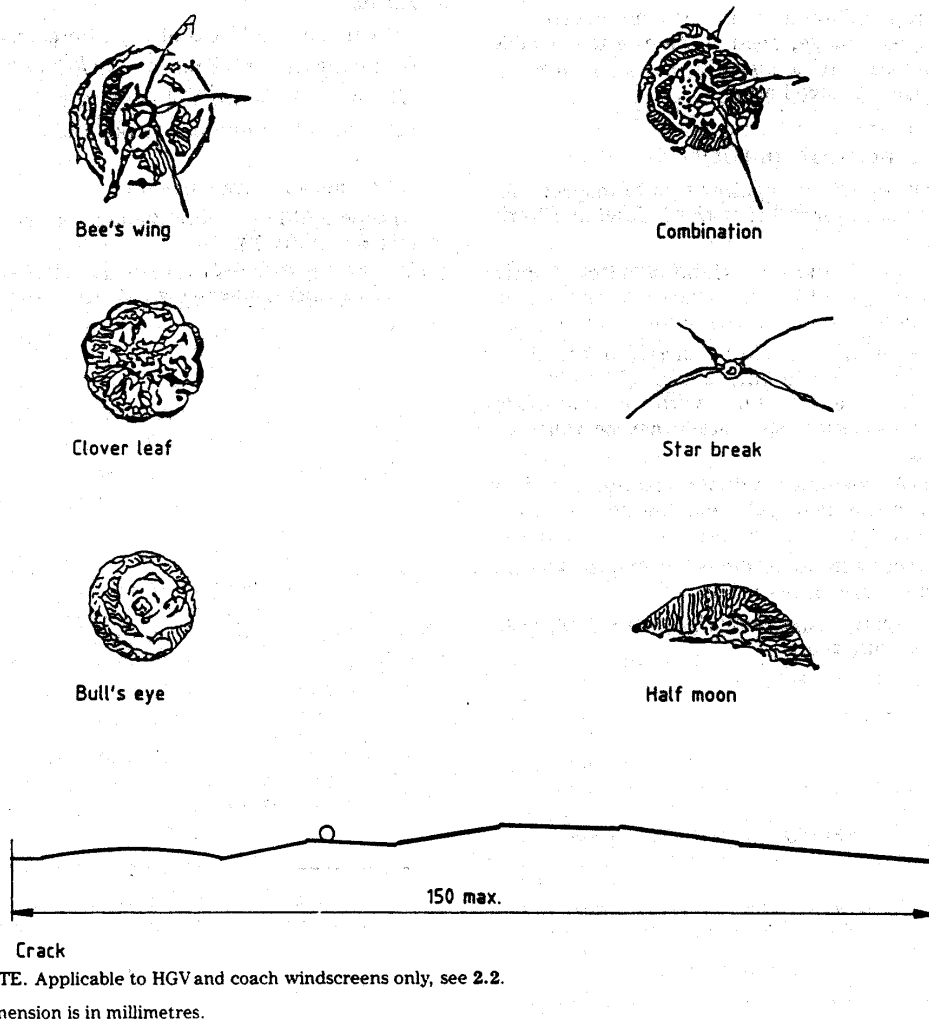

Figure 6 Identification of types of windscreen damage

3.4.8 AGE AU 251. British Standard. Part I – Specification for Performance of Automotive Laminated Windscreen Repair Systems. Part II – Code of Practice on Repair Methodology

Scope

This British Standard specifies performance requirements for windscreen repair systems, including the materials used, to be employed for the repair of laminated windscreens that have been damaged by impacts. This standard is applicable to repair systems to be used for the repair of windscreens of passenger cars.

Categories of Damage

These are shown in Figure 6.

Tests

This standard outlines a number of relevant tests including:

8.5 *Visual appearance test*

8.6 *Optical distortion test*

8.7 *Light scatter test*

3.5 AUSTRALIAN ROADWORTHINESS GUIDELINES

Vehicle roadworthiness guidelines define legal requirements to ensure a minimum level of safety for vehicles. They focus on the safety related aspects of vehicles and aim to ensure that they have not worn or deteriorated to an extent that they have rendered the vehicle unsafe for use.

The assessment of vehicle roadworthiness falls under the authority of individual jurisdictions in Australia (ie: road authority in each State or Territory). The National Road Transport Commission has developed draft (national) roadworthiness guidelines (September 1995). Each jurisdiction may develop and use their own guidelines for the assessment of vehicle roadworthiness based on available Australian Standards (and often base these on the national draft guidelines).

Below are summaries of the various roadworthiness guidelines relating to windscreen degradation, damage or windscreen strength currently used around Australia¹.

3.5.1 National Road Transport Commission's "Roadworthiness Guidelines", September 1995²

These guidelines are to be updated to reflect the ASVRs 1999.

Part 10: Windscreens and Glazing

The National Road Transport Commission (NRTC) released draft "Roadworthiness Guidelines" in September 1995. This document was developed as part of the organisation's task of developing uniform laws and administrative guidelines "for the safe and efficient operation of road transport in Australia" (p1 of the draft document).

Part 10 (page 26) of this document addresses the roadworthiness of windscreens and glazing.

Several Australian jurisdictions have based their roadworthy guidelines directly on this document.

¹ These guidelines were current as of December 1999 and were obtained directly from the road traffic authority in each Australian jurisdiction.

² The National Road Transport Commission (NRTC) was established in 1991 by the unanimous agreement of all Heads of Government. The NRTC works closely with a number of bodies to develop practical reforms which:

- Make road transport and road use more innovative, efficient and safe;
- Introduce greater national transport uniformity and consistency;
- Reduce the environmental cost of road transport; and
- Reduce the costs of administration of road transport.

The roadworthiness guidelines are to be updated to reflect the AVSRs 1999.

It is noted at the start of this section in the document that a number of Vehicle Standards are of relevance:

- Clause 2.5 Driver's View and Control of Vehicle;
- Clause 2.15 Windscreens and Windows;
- Clause 2.16 Window Tinting; and
- Clause 2.17 Windscreen Wipers and Washers.

The following Australian Design Rules were noted as also being relevant:

- ADR 8 Safety Glazing Material;
- ADR 12 Glare Reduction in Field of View;
- ADR 15 De-misting of Windscreen;
- ADR 16 Windscreen Wipers and Washers; and
- ADR 42 General Safety Requirements.

This document identifies the general criteria for assessing whether a windscreen should be replaced or repaired (where appropriate). The following sections are of relevance to the present project.

A windscreen should not be considered roadworthy when,

10.1 General (p 26)

- (a) *“Glazing is loose in its frame or cracked to the extent that sharp edges are exposed*
Note: Many vehicles have glazing that is bonded to the window frames to increase the strength of the passenger compartment. Replacement glazing in these vehicles must be bonded using an adhesive of suitable strength.”
- (b) *“Glazing that is necessary to allow the driver to see the road is discoloured, obscured, badly scratched, sandblasted or fractured to the extent that it interferes with the driver's view.*
Note: Grooves in windscreens that are designed specifically to clean wiper blades are not regarded as damage unless they seriously affect the driver's view. Approved grooving is usually identified by the installer.”
- (c) *Items that could obscure the driver's view are placed in the area of the windscreen described in 10.2(a) or the corresponding area on the other side of the windscreen.”*

10.2 Windscreen (p 26/27)

- (a) *“For the wiped area of the windscreen in front of, and on the same side of the centre of the vehicle as the driver, shown in Figure 7 (below) as Area A, any bulls-eye and star fractures exceed 16mm in diameter.”*

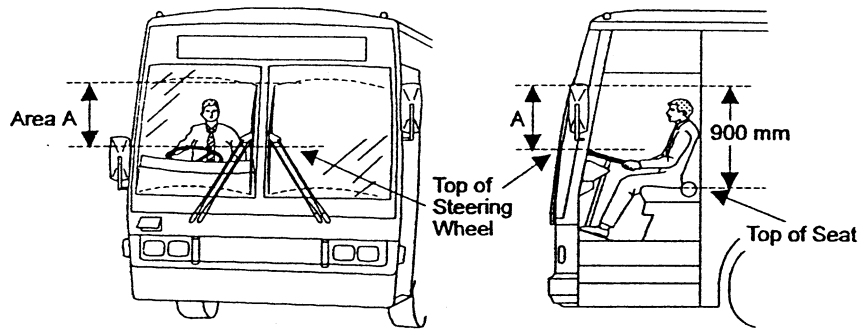

Vehicles with a GVM of more than 3.5 tonnes

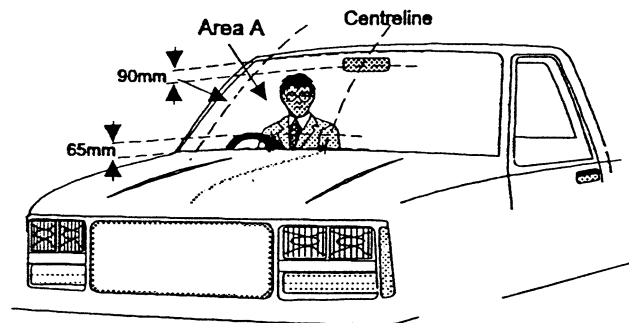

Vehicles with a GVM of not more than 3.5 tonnes

Figure 7 Primary Vision Area of Vehicles

Note: Area A does not include any areas not in the primary vision area as described in the ADRs.

- (b) *Any cracks in a laminated windscreen penetrate more than one layer of glass or are more than 150mm long.*

3.5.2 Victoria

In Victoria, the “Vehicle Standards Information 26. Roadworthiness Requirements, May 1999” is currently used for the assessment of vehicle roadworthiness.

The following section from this document is of relevance for the assessment of windscreen roadworthiness.

Section G Windscreen and Windows

(Primary Vision Area)

“For cars and other light vehicles, the primary vision area can be approximated by excluding the area above the wiper arc or the top 10% of the windscreen, whichever is greater.... (p 8)”

(Damage / Degradation)

“It must be accepted that during service the windscreen will be subject to some damage such as sandblasting, cracks, bulls eyes, and various other types of fractures. Therefore the roadworthiness requirements for windscreens allow for some deterioration from the

new condition. A windscreen with minor damage which does not exceed the requirements set out in this section should not fail during a roadworthy inspection.

That part of the primary vision area of the windscreen to the right of the centre line and swept by the blades must not be cracked, scored, chipped, badly sandblasted or otherwise defective so as to interfere with the driver's vision. In addition parts of the windscreen traversed by wiper blades must not be cracked or chipped to an extent likely to damage the wiper blades.

In a repaired windscreen a faint outline of the repaired damage or in some cases a slightly dull spot may be visible where the repair has been performed. A repaired crack may also be detectable by a fine hairline surface mark. These are acceptable and should not be rejected during a roadworthy test providing the rest of the windscreen complies with the requirements as set out in this section.

In addition windscreens which have evidence of sandblasting should not be rejected unless the sandblasting is considered heavy to the extent that it would be considered a safety hazard."

3.5.3 New South Wales

The roadworthiness guidelines currently used in New South Wales are based on the National Road Transport Commission's "Roadworthiness Guidelines", September 1995 (as summarised above).

3.5.4 Tasmania

In Tasmania, the "Light Vehicle Information Bulletin" is used by inspectors for assessing the suitability of vehicles for registration.

The relevant sections are shown below.

Windscreens Section

The "windscreen" bulletin "*is a guide to the requirements for windscreens in light vehicles and covers windscreen material, windscreen visibility, windscreen damage and repairs*" (p 1 of 3).

This document divides the windscreen into three vision areas,

1. Critical vision area

"For light vehicles this is an area 220mm wide for the depth of the windscreen in the wiper arc, but excluding the area above the wiper arc or the top 10% of the windscreen, whichever is the greater".

See Figure 8.

"For heavy vehicles including buses with large windscreens, is an area 220mm square. Exclude the area above the wiper arc or above the horizontal line 200mm above the height of the driver's eye when seated in the normal position, whichever is the greater and the area below the top of the steering wheel when looking from the driver's seat in the normal seated position

2. Primary vision area

"Area is that area outside the critical area and to the right of the centre line of the windscreen".

3. Secondary vision area.

“Area that is part to the left of the centre of the windscreen”.

With respect to other windows on the vehicle the document states,

“The vision through all other windows fitted to a motor vehicle shall not be obscured or obstructed by any item or fitting.”

Diagram A (light vehicles)

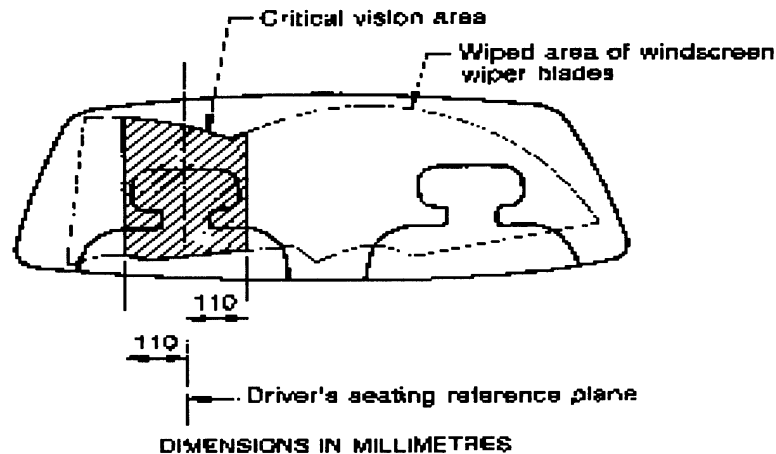

Diagram B (heavy)

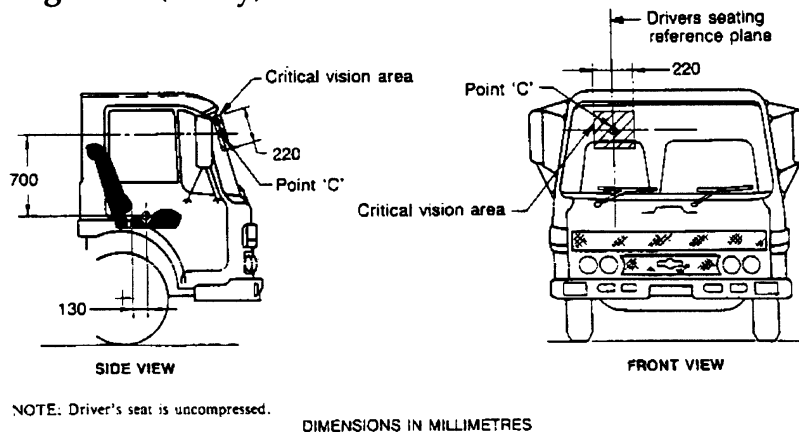

Figure 8 Critical Vision Area for Light and Heavy Vehicles

Damage

When considering damage the document states,

“It must be accepted that during normal use a windscreen will be subject to some damage such as sandblasting, cracks, bulls eyes, and various other types of fractures. Therefore the roadworthiness requirements for windscreens allow some deterioration from the new condition. A windscreen with minor damage which does not exceed the requirements set out in this section should not be failed during a roadworthiness inspection.”

With respect to visible damage to the windscreen the document states,

Critical Vision Area

“There must be no damage of any type in the critical vision area of any vehicle type, this includes any scratching caused by defective wiper blades or wiper arms.”

Primary Vision Area

“Light vehicles may have finished cracks or single wiper arm scratches up to 100mm, star or bulls eyes up to 5mm or craters up to 2mm, providing they do not interfere with the operation of the wiper blades.

Heavy vehicles and buses with large windscreens are permitted finished cracks or single wiper arm scratches up to 150mm, star or bulls eyes up to 10mm and craters up to 5mm. The area below the top of the steering wheel when looking from the driver’s seated position is excluded for this purpose.”

Secondary Vision Area

“Light vehicles may have finished cracks or single wiper arm scratches up to 200mm, star or bulls eyes up to 10mm and craters up to 5mm.

Heavy vehicles may have finished cracks or single wiper arm scratches up to 300mm, star or bulls eyes up to 25mm and craters up to 10mm.

NOTE: Where a vehicle has two or more pieces of damage, each of which reach or exceed the dimensions for the particular vision area then the vehicle is not longer roadworthy.”

EXAMPLES OF WINDSCREEN DAMAGE:

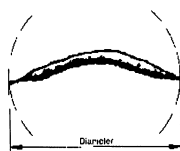

Figure 1: CRACK DAMAGE

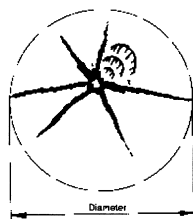

Figure 2 STAR DAMAGE



Figure 3 BULLSEYE DAMAGE



Figure 4: CRATER DAMAGE



Figure 5: EXAMPLE OF COMBINATION DAMAGE WITH MULTIPLE INCIDENCES OF THE ONE CHARACTERISTIC INCIDENCE)

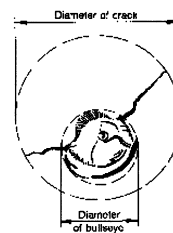

Figure 6: EXAMPLE OF COMBINATION DAMAGE WITH MORE THAN ONE FUNDAMENTAL DAMAGE (SINGLE INCIDENCES)

Figure 9 Examples of Windscreen Damage

Repairs

“In a repaired windscreen a faint outline of the repaired damage or in some cases a slightly dull spot are acceptable where the repair has been performed. A repaired crack may also be detectable and should not be rejected during a roadworthiness test providing the rest of the windscreen complies with the requirements as set out in this section.

Laminated windscreens may have discolouration up to 25mm from the edge of the visible glass area.

Windscreens with widespread wiper blade or wiper arm scoring should be rejected.

Windscreens which have evidence of sandblasting should not be rejected unless the sandblasting is considered heavy to the extent that it would be a safety hazard.

Apart from any pillar or other part of the vehicle’s structure or fittings, there must be no internal obstructions to a driver’s view through the swept area of the windscreen, to the right of the driver’s position, except for the area outside the primary vision area.

Glazing material must not be broken in any area exposing sharp or jagged edges.

All windscreen repairs are to comply with Australian Standard AS 2366 – 1990 “Repair of Laminated Windscreen Fitted to Road Vehicles.”

3.5.5 Australian Capital Territory

A motor vehicle inspection manual has been developed in the Australian Capital Territory to guide roadworthy assessors to determine if a vehicle is no longer roadworthy.

Section 105.02 instructs inspectors to visually examine the windscreen and front side windows.

Reason for rejection

The guidelines for when to reject a windscreen as unroadworthy are,

“a) the area of the windscreen from the centre of the vehicle in front of the driver has cracks or is deteriorated to the extent that it interferes with the driver’s view.

EXCEPTION: Any two of the following types of damage are acceptable,

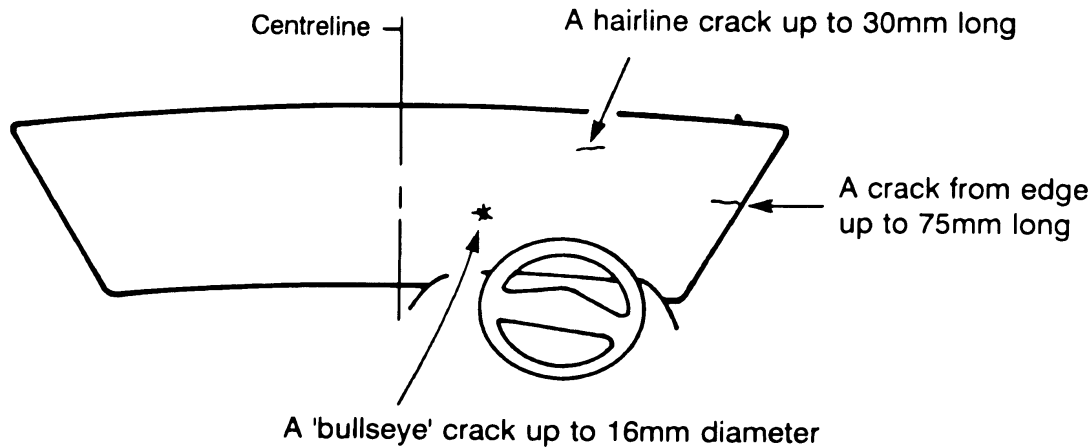

Figure 10 Area for Visual Inspection of Windscreen

NOTE: This rule applies to windscreens repaired with clear resins. After repair, there must be no visible damage beyond the limits given above.

3.5.6 South Australia

The roadworthiness guidelines currently used in South Australia are based on the National Road Transport Commission's "Roadworthiness Guidelines", September 1995 as summarised above.

3.5.7 Queensland

Queensland Transport has released a number of information bulletins relating to the roadworthy assessment of motor vehicles.

Information bulletin VSO.14.5/97 is titled "Replacing or Repairing Windscreens". The following information, provided in the bulletin, is of relevance here.

"Introduction

Windscreen damage or defects may impair a driver's forward vision, create a potential safety hazard and affect road safety. However, windscreens will be subject to some damage such as sandblasting, cracks, and stone chips during normal operation, therefore some deterioration from new condition is allowable.

A windscreen should be clean and free of damage that might impair the driver's view to the front of the vehicle.

Things which might impair a driver's vision are:

- *Damage to windscreens such as cracks, chips, and discolouration;*
- *Road grime, dirt or grease on either the inner or outer surface of the windscreen; or*
- *Damage to the windscreen wiper blades or arms, deterioration or non-operation.*

Is a damaged windscreen safe?

When a damaged windscreen is examined the following factors should be considered:

- *The location of the damage;*
- *The size of the damage; and*
- *Effect on the mechanical strength of the windscreen.*

To determine if a windscreen should be replaced or repaired, the area of windscreen swept by the wipers to the right of the centre of the vehicle (see Figure 9, below) may have bullseyes and start fractures up to 16mm in diameter and cracks up to 150mm long which do not penetrate more than one layer of the glass in a laminated windscreen, provided they do not interfere with the driver's vision.

In addition the "primary vision area" (the area of the windscreen which is swept by the windscreen wipers) must not be cracked, scored, chipped, sandblasted or otherwise damaged to the extent that it impairs the driver's vision or damages the wiper blades.

It is recommended that all defects be repaired as soon as possible.

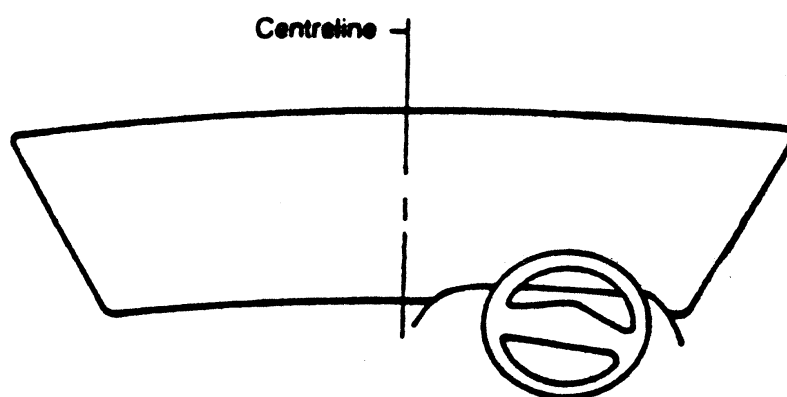

Fig 1

Figure 11 Area to Inspect to Determine whether Windscreen should be Replaced or Repaired

3.5.8 Northern Territory

The Northern Territory Department of Transport Works requires windscreens to comply with the relevant Australian Standards. For example, all windscreen repairs should comply with AS 2366 – 1990.

3.5.9 Western Australia

The roadworthiness guidelines currently used in Western Australia are based on the National Road Transport Commission's "Roadworthiness Guidelines", September 1995 as summarised above.

With regard to sandblasting damage, the assessment is left to the discretion of the inspector (Rex Middleton, Western Australia Transport, Personal Communication).

3.6 ADMINISTRATIVE GUIDELINES: ASSESSMENT OF DEFECTIVE VEHICLES (FEBRUARY 1999)

The NRTC Administrative Guidelines for the Assessment of Defective Vehicles was designed “to help enforcement officers determine the significance of vehicle defects relative to the safety risk they present on the road” (Explanatory Notes to the document).

The Explanatory Notes to this document indicate that this document was designed to be used in conjunction with:

- the Road Transport Reform (Heavy Vehicle Standards) Regulations 1995, which set out in-service technical requirements for the construction and performance of heavy vehicles; and
- the associated Roadworthiness Guidelines which provide practical information about wear or damage to the important vehicle systems.

“This guideline provides a decision making process to help enforcement officers to determine:

- the significance of vehicle defects relative to the safety risk they present; and
- the appropriate course of action to take in terms of issuing a vehicle defect notice.”

The guideline takes account of the interaction between the type of defect, how the vehicle is being used, and the road environment to determine the overall risk of the vehicle being involved in a serious crash” (Explanatory Notes to the document).

3.6.1 National Road Transport Commission’s Classification of Windscreen Damage

The NRTC classifies damage to the windscreen as follows,

- | | |
|---|--------------------------|
| a) Glazing is loose in its frame or cracked to the extent that sharp edges are exposed. | Minor |
| b) The windscreen is discoloured, obscured, badly scratched, sandblasted or fractured to the extent that it interferes with the driver’s view. | Minor |
| c) Fittings that obscure the driver’s view are placed in the windscreen area. | Minor-Major |
| d) Any cracks in a laminated windscreen penetrate more than one layer of glass or more than 150 mm long. | Minor |
| e) For the wiped area of the windscreen in front of the driver any bullseye or star fracture exceeds 16 mm in diameter so as to interfere with the driver’s view. | Minor |
| f) Windscreen wipers do not work. | Dry: Minor
Wet: Major |
| g) Wiper blade rubbers are missing. | Dry: Minor
Wet: Major |
| h) Wiper blade rubbers are cracked, hardened or frayed. | Minor |
| i) Windscreen washers do not work. | Minor |
| j) Windscreen demister does not work. | Minor |

SUMMARY

- A range of standards and guidelines were identified both internationally and within Australia and New Zealand.
- A major concern is the lack of consistency between many of these documents particularly in terms of specifying damage and repair or replacement requirements. For example, some give specific and objective measuring criteria including diagrams, others offer very general and subjective guidelines, while some don't even address some of the important issues.
- This suggests the need for some type of standardisation, at least in Australia, but possibly internationally as well.
- The majority of the documents reviewed seem to address the issue of sudden impact damage, including cracks and bulls eyes at least to a limited extent while many of these documents give detailed descriptions and objective criteria for assessing this type of damage. Again, the comprehensiveness of this varies between documents.
- In contrast, the majority of the documents reviewed do not address the issue of degradation or "hazing". Moreover, in those documents that do attempt to address this issue, the guidelines are often vague and subjective. The lack of objectivity is largely due to a lack of low cost measuring equipment capable of widespread use in determining the need for windscreen repair or replacement. Only one document was identified that has attempted to specifically address and quantify this type of damage (German Standard DIN 52298-1).
- The Motor Vehicle Standards Act 1989 has recently been reviewed by the federal government (see <http://www.dotrs.gov.au/land/vehicle/review/review.htm>).
- A review of the current standards and roadworthiness guidelines relating to windscreen repair and replacement would seem appropriate at this stage. In particular it would be useful to consider the role of standards and guidelines and how they could be made clearer and more objective.
- There is clearly a need for a low cost measuring device that could be widely available to government agencies and the repair industry in general to aid the objective assessment of windscreen damage (resulting from gradual wear) to make the repair and replacement more effective.

4 MEASUREMENT OF WINDSCREEN DEGRADATION

This section describes and reviews devices and techniques that are currently available to measure windscreen degradation. Firstly though it is necessary to briefly describe some key elements in the measurement of scattered light.

Dr Daniel Malaise, founder of Daniel Malaise Optics (DMO), has described the measurement of scattered light in windscreens (Malaise, 1998). The influence of scattered light depends upon three factors; the angular position and intensity of the light source (eg: sun, head lights); the contrast of the target; and the wear of the windscreen. The wear of the windscreen is the only one of these three parameters that can be measured scientifically, but it must be measured independently from the other two parameters.

In the field of optics, the scattering of light from a polished surface is characterised by the bi-directional scattering distribution function (BSDF). This function defines the relative quantity of scattered light as a function of the incidence of the scattered beam angle with a normal surface. Both the reflective and transmitting sides of the scattering surface have their own scattering distribution functions. As will be discussed shortly, most devices and techniques that assess windscreen degradation measure scattered light by calculating the proportion of scattered light versus the proportion of good useable light (in some form), which is expressed as a Scattered Light Index (SLI). The SLI will be discussed in detail shortly, but it should be noted that the SLI (defined in the German Standard DIN 52298) is equivalent to the scattering distribution function on the transmitting side of the scattering surface at 1.8 scattering angle, multiplied by the transmission of the window.

4.1 AN EARLY TECHNIQUE TO MEASURE WINDSCREEN DEGRADATION

One of the earliest techniques for measuring the extent of windscreen degradation was described by Allen (1969). This laboratory-based technique initially involved taking photographs of the headlights of an oncoming car through the windscreen. Windscreens were set at an installation angle of 35 degrees. To measure the extent of light scatter, layers of translucent plastic polyethylene were layered over the photograph of the scratch pattern until the scratch pattern could barely be seen. The number of layers required provided a crude index of the extent of windscreen scratching. This index was represented on a non-linear scale as the difference between layers 1 and 2 is greater than the difference between layers 9 and 10.

4.2 MODERN TECHNIQUES FOR MEASURING WINDSCREEN DEGRADATION

Modern techniques express the degree of windscreen degradation in terms of the ratio of the intensity of stray light to the intensity of useful light, as it is believed that is it this ratio that is critical for the driver (Timmermann, 1985b). This ratio is called the reduced luminance coefficient, and is also referred to as the SLI. The higher the SLI, the greater the degree of light scattering and hence windscreen degradation.

The following section will describe a number of measurement techniques. Discussions here will initially focus on the Hazemeter, as used in accordance with an American National Standard, and will then move to discuss more recent techniques, with an emphasis on mobile (as opposed to laboratory-based) testing devices.

The Hazemeter

Standard Test Method for Haze and Luminance Transmittance of Transparent Plastics – American Standard D 1003 – 61 (Reapproved 1977)

This Standard (approved in 1961 originally and re-approved in 1977) describes a method for testing for haze and luminous transmittance of transparent plastics. Haze has been described in this documents as,

“-that percentage of transmitted light in which passing through the specimen deviates from the incident beam by forward scattering. For the purpose of this method only light flux deviating more than 2.5 deg on the average is considered to be haze.”

Although the Hazemeter measures in terms of haze, the measurement of the haze has similarities with the SLI. The Hazemeter calculates the percentage haze based upon the diffuse transmittance and the total transmittance of the surface.

This document outlines the method for measuring haze, as described below.

“Procedure A Using the Hazemeter

7 Apparatus

7.1 *The Hazemeter shall be constructed essentially as shown in Figs 12 & 13 and shall conform to the requirements of 7.2 through 7.9.*

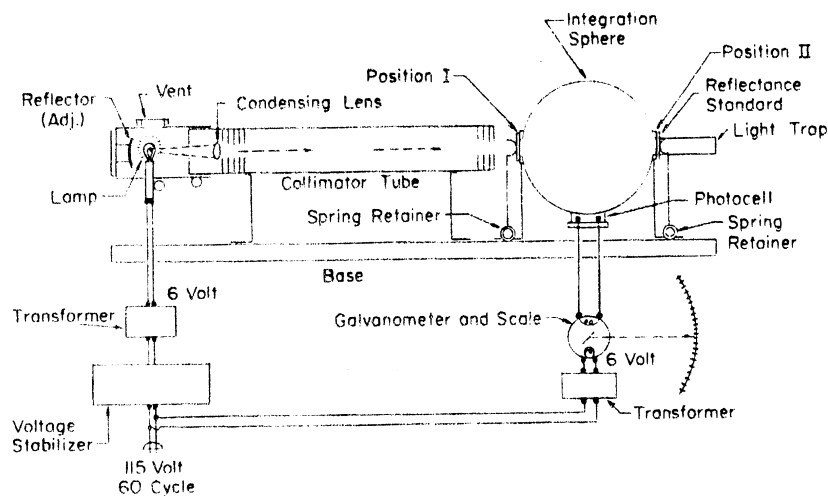

FIG. 1 Hazemeter

Figure 12 “Hazemeter”

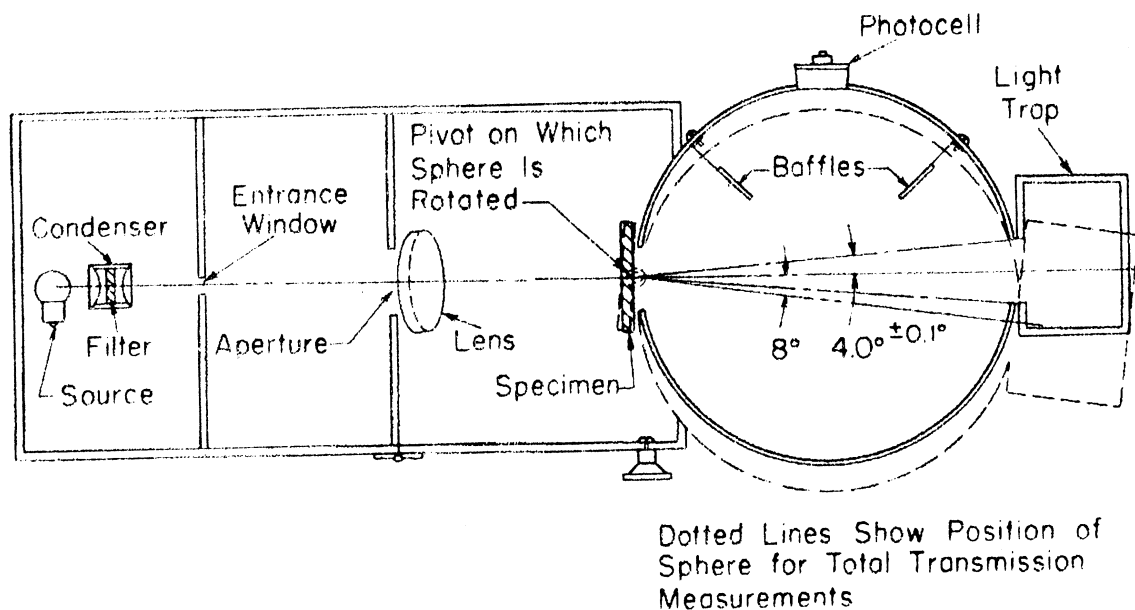

FIG. 2 Pivatable-Sphere Hazemeter

Figure 13 "Pivatable Sphere Hazemeter"

- 7.2 An integrating sphere shall be used to collect transmitted flux: the sphere may be of any diameter so long as the total port area does not exceed 4.0 percent of the internal reflecting area of the sphere.
- 7.3 Figures 12 & 13 indicate possible arrangements of the apparatus. These contrast with that of Procedure B (for measuring luminance) in that specimen and standard beams are the same beam. The entrance and exit ports shall be centred on the same great circle of the sphere and there shall be at least 170 degrees of arc between centres. The exit port shall subtend an angle of 8 degrees at the centre of the entrance port. The axis of the irradiating beam shall pass through the centres of the entrance and exit ports. The photocell or photocells shall be positioned on the sphere 90 \pm 10 degrees from the entrance port. In the pivatable modification of this type (Fig. 13) designed to use the interior sphere wall adjacent to the exit port as the reflectance standard, the angle of rotation shall not exceed 10 deg.
- 7.4 The specimen shall be illuminated by a substantially unidirectional beam: the maximum angle which any ray of this beam makes with the direction of its axis shall not exceed 3 deg. This beam shall not be vignetted at either port of the sphere.
- 7.5 When the specimen is placed immediately against the integrating sphere at the entrance port, the angle between the normal to its surface and the axis of the beam shall not exceed 8 deg.
- 7.6 When the beam is unobstructed by a specimen, its cross-section at the exit port shall be approximately circular, sharply defined and concentric within the exit port, leaving an annulus of 1.3 \pm 0.1 deg subtended at the entrance port.

Note: It is important to check the unobstructed-beam annulus dimensions whenever apertures or focus are changed.

- 7.7 The surfaces of the interior of the integrating sphere, baffles, and reflectance standards shall be substantially equal reflectance, matte, and highly reflecting throughout the visible wave lengths.
- 7.8 For some measurements the standard at the exit port is replaced by a light trap by actual removal of the reflectance standard or by pivoting the sphere (Fig 13). The light trap shall absorb the beam completely when no specimen is present.
- 7.9 The radiant flux within the sphere shall be measured by a photoelectric cell, the output measurements of which shall be proportional within 1 percent to the incident flux over the range of intensity used. Spectral conditions for source and receiver must be constant throughout the test of each specimen. The design of the instrument shall be such that there shall be no galvanometer deflection when the sphere is dark.

8 Apparatus

8.1 Determine the following four readings:

Reading Designation	Specimen in Position	Light Trap in Position	Reflectance Standard in Position	Quantity Represented
T ₁	No	No	Yes	Incident light
T ₂	Yes	No	Yes	Total light transmitted by specimen
T ₃	No	Yes	No	Light scattered by instrument
T ₄	Yes	Yes	No	Light scattered by instrument in specimen

8.2 Repeat readings for T₁, T₂, T₃ and T₄ with additional specified positions of the specimen to determine uniformity.

9 Calculation

9.1 Calculate the total transmittance, T_t (See Note above), equal to T₂/T₁.

9.2 Calculate diffuse transmittance, T_d (see Note above), as follows:

$$T_d = [T_1 - T_2 (T_2/T_1)]/T_1$$

9.3 Calculate percentage of haze as follows:

$$\text{Haze percent} = T_d / T_1 \times 100$$

Note: To obtain luminous transmittance values (total, T_t; diffuse T_d) by this procedure, a proper source filter-photocell system must be employed

4.3 STRAY LIGHT

As mentioned earlier, most modern techniques for assessing windscreen degradation focus on measuring the SLI of the windscreen surface. Before talking further about these devices, it is important to briefly discuss how the analysis of stray light can be used to highlight different types of windscreen damage. Derkum (1991b) has shown that the stray light emanating from different types of damage (eg: craters, wiper damage, scratches) produces different types of distributions, as illustrated in Figures 14-16.

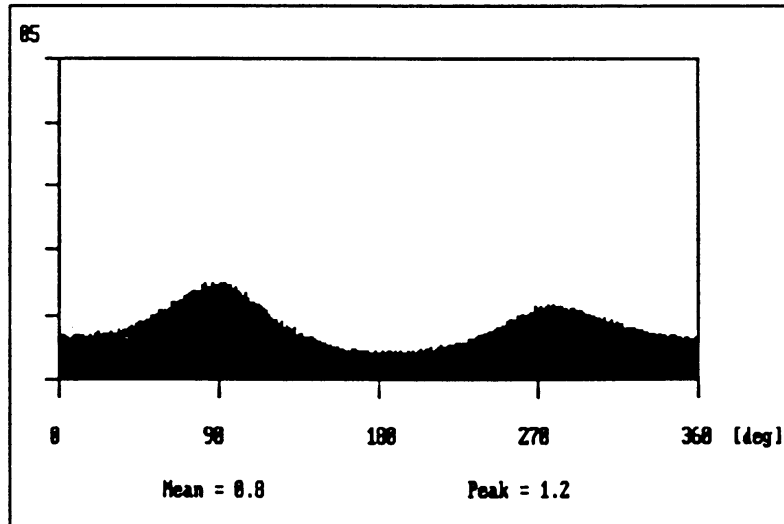

Figure 14 Stray Light Diagram of a Windscreen with Craters (Derkum, 1991b)

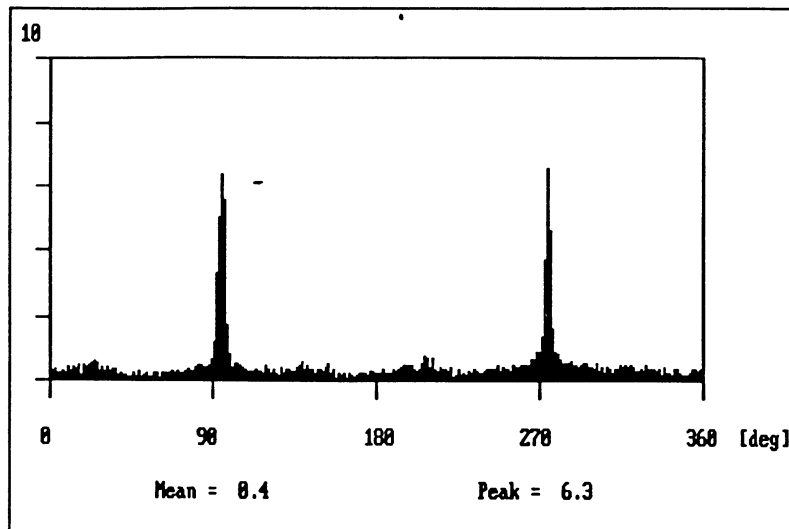

Figure 15 Stray Light Diagram of a Windscreen with Wiper Damage (Derkum, 1991b)

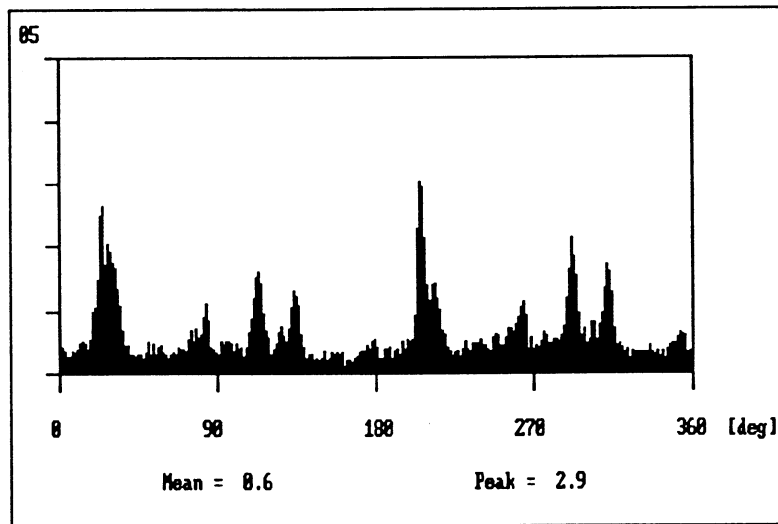

Figure 16 Stray Light Diagram of a Windscreen with Irregular Scratches from Ice Scraping (Derkum, 1991b)

Clearly the different types of windscreen damage (craters, scratches, wiper damage) result in different stray light characteristics. Derkum reported that these types of windscreen damage do also differ in their effects on visual perception. As a result, it is important to consider both the specific type of damage (crater, wiper damage, scratches) in addition to the stray light mean value.

The need to consider the type of windscreen damage, and not simply the SLI, is highlighted when looking at the distribution of SLI in vehicles across different regions. Data from 896 vehicles in Köln shows that only 2.4% had SLI values greater than 1.5. In contrast, 21.1% of 218 vehicles in Norway were found to have SLI values greater than 1.5. These differences are likely to be due in part to the different climates and environments between the regions, and perhaps different types of windscreen damage. These regional differences also raise the issue of the appropriate cut-off SLI value for labelling windscreens as having adequate or impaired visibility. It was suggested that a physical parameter needs to be found that encompasses both the type of windscreen damage as well as the SLI value.

Derkum (1991b) also researched some more specific aspects of how stray light should be measured. Not only are there likely to be different types of damage within the one windscreen, it is also highly likely that the extent of any damage would not be constant across the whole windscreen. Hence one issue in the measurement of stray light is the number of windscreen measurements required in order to obtain an accurate representation of the windscreen damage across the drivers field of view. Pilot testing suggested that an average of six measurements in the main visual field of the driver would accurately describe the windscreen condition (for the driver). Three measurements of windscreen degradation were made at the height of the headrest, one of which is directly over the middle of the steering wheel, with the other two readings at either side. The remaining three readings were taken 10 cm lower than the headrest. Regression analyses revealed that two readings were sufficient to get a multiple correlation of 0.98 with the average, and three readings provided a correlation of 1.00. Derkum therefore concluded that two readings were sufficient to obtain an accurate representation of the condition of the windscreen (in the drivers main field of view) when considering the average of six measurements. Through his studies Derkum also confirmed that the windscreen must be in

its mounted position (at the mounted angle) when the stray light is measured to acquire the appropriate information about the drivers' perception.

4.4 THE STRAY LIGHT INDEX AS A MEASURE OF WINDSCREEN DEGRADATION

As mentioned earlier, most techniques use the SLI as a measure of windscreen degradation. The SLI and modern techniques for measuring it mean that it is possible to collect the amount of data necessary to correlate values for light scatter with degradation of visual perception within a reasonable time. As such it is possible to determine the effects of worn windscreens on the safety of road traffic (Timmermann, 1985a).

Timmermann (1985a) described the development of a modified Hazemeter called the stray light analyser. According to Timmermann, it is the ratio of the intensity of stray light to the intensity of useful light that is important for the driver (or the SLI) (Chmielarz, Groetzner & Haase, 1987 also discuss the SLI). The stray light analyser measures the SLI in mounted windscreens.

Unlike the traditional Hazemeter described earlier, the stray light analyser described by Timmermann restricts the measurement of stray light to a limited range of angles, from 1.5 to 2 degrees. As explained by Timmermann there are a number of reasons for this limited range of angles (Timmermann, 1985a). Firstly, this range is in accordance with the DIN standard 4646 for the measurement of the reduced luminance coefficient (or SLI). Secondly, with respect to night driving, the headlight of an oncoming car at a distance of 60 m and at a lateral distance of 1 m will appear at an angle of approximately 1.75 degrees relative to the forward direction. Finally, the intensity of the scattered light drops dramatically as the angle increases. The scattered light intensity is higher with smaller angles, such as under 2 degrees, which results in faster operation and higher precision.

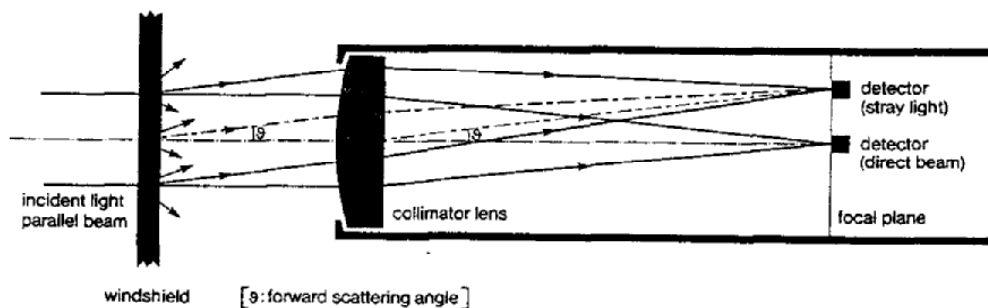

Figure 17 Schematic Drawing of the Stray Light Measuring Device. The Stray Light Detector Moves Around the Direct Beam Detector to give the Azimuth Resolution (from Timmermann, 1985a, p. 334).

A light beam of 3.5 cm diameter is incident with the windscreen (see Figure 17). The direct beam, or the useful light, is directed by the collimator lens to a point where it can be measured by the detector. The light that is scattered in the angles of 1.5 to 2 degrees is imaged as a ring onto the focal plane, and the scattered intensity is measured by the second detector. This device does automatically correct for possible scattering that may take place within the instrument itself resulting from dust particles on the lens. It takes about seven seconds to obtain a complete measurement using this device.

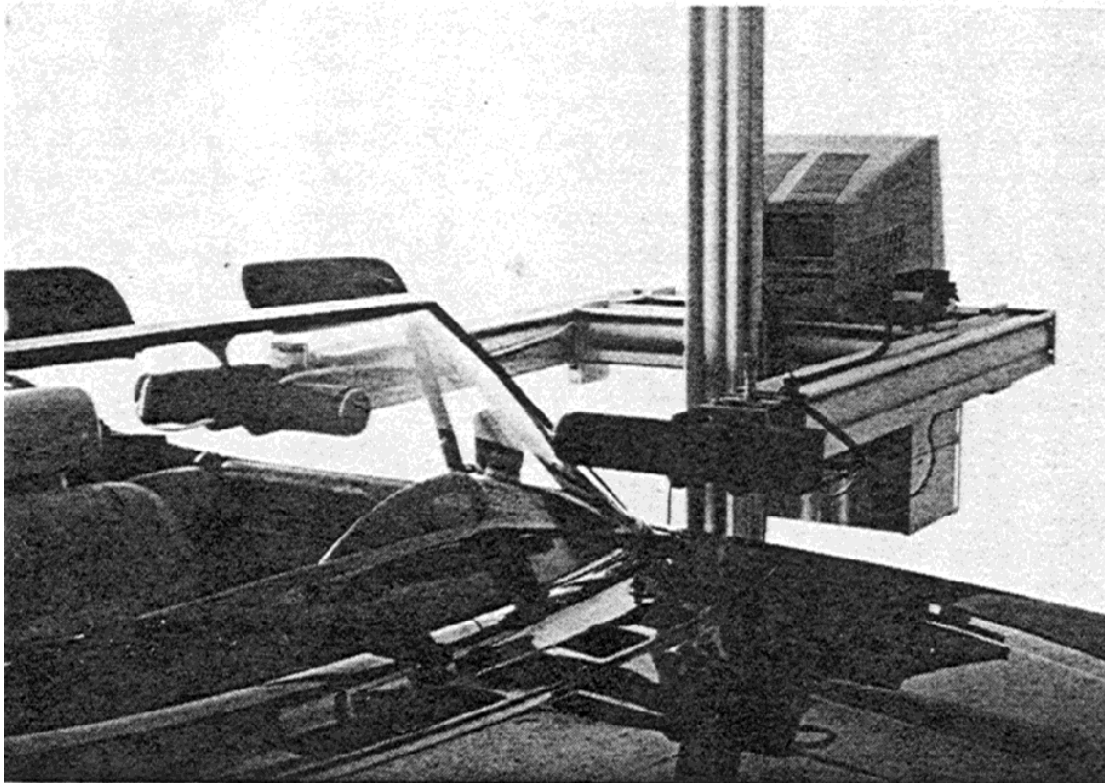

Figure 18 An Instrument to Measure SLI Values on Mounted Windscreens (from Timmermann, 1985a, p. 335).

The major advantage of this device over the traditional Hazemeter is that it can be used in the field and in mounted windscreens (see Figure 18). An example of the information contained in a typical stray light diagram is illustrated below (Figure 19). The two features are the peak SLI which corresponds to wiper damage, and the mean SLI which represents the approximate contribution of crater damage.

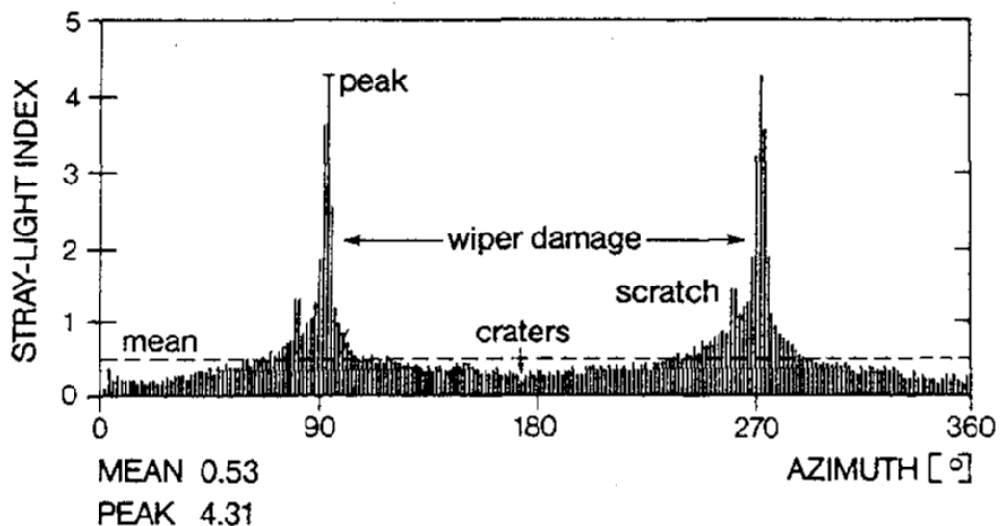

Figure 19 An Example of a Stray Light Diagram with both Mean and Peak SLI Values Displayed (from Timmermann, 1985a, p.335).

4.4.1 The Angular Diaphragm Method of Measuring Scattered Light

This section describes the technique for measuring scattered light in accordance with the German Standard DIN 52998-1. The total scattered light is recorded in the area between the angles of 1.5 and 2.0 degrees to the forward undisturbed transmitted light. The average value of the reduced luminance coefficient is used to determine the measure of scattered light.

The testing arrangement is highlighted below in Figure 20, and descriptions are contained below the figure. The measuring conditions are shown in Table 3.

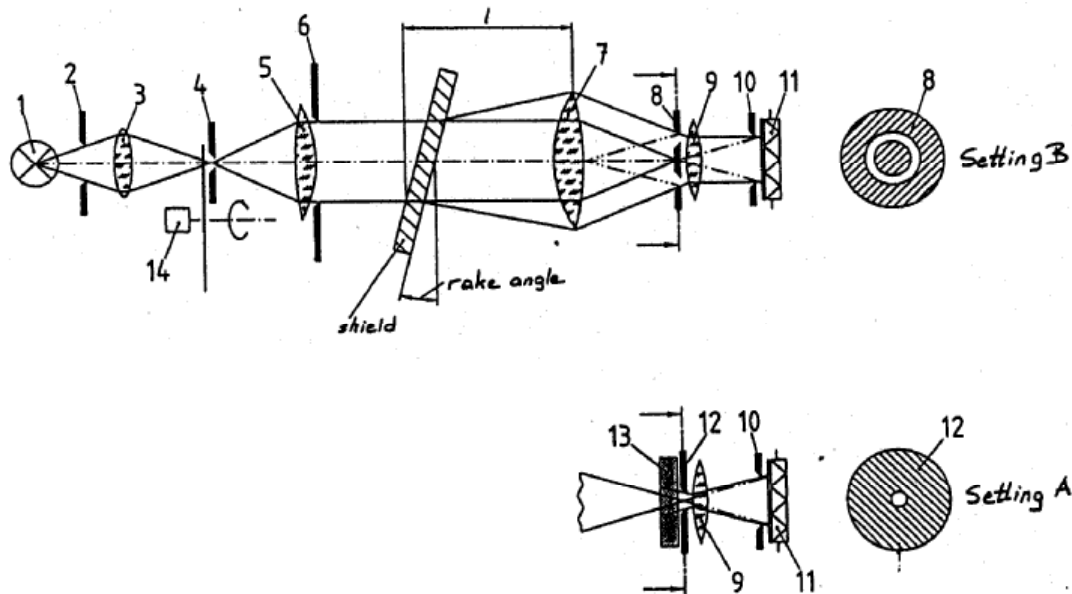

Figure 20 The testing arrangement to measure scattered light according to the annular diaphragm method

The components of the testing arrangement illustrated in Figure 20 are as follows:

1. Light source
2. Field lens
3. Intermediate lens
4. Aperture lens
5. Collimator
6. Aperture lens
7. Collector
8. Annular lens
9. Field lens
10. Scattered light lens
11. Photometric head
12. Aperture lens
13. Neutral filter
14. Chopper

Procedure:

The light source (1) is imaged onto the aperture lens (4) by the intermediate image lens (achromatic) (3) with the same size, the aperture lens being situated in the focal plane of the collimator (achromatic) (5). The collimator produces a quasi-parallel light beam which passes through the windscreen to be tested. The collector (7) images the aperture lens (4) in its focal plane. In this plane, and centrally with the optical axis, there is either the aperture lens (12) (setting A) or the annular lens (8) (setting B). The annular lens covers the light passed through directionally and allows scattered light to exit at angles between 1.5 and 2.0 degrees relative to the passing-through direction with any azimuth angle. The aperture lens covers the scattered light occurring and allows the light, passed through directed, to exit.

The field lens (9), which is situated directly behind the plane of the lens in setting B, images the windscreen on a reduced scale on the photometric head (11). At the same time, the image from the aperture lens (6) is formed on the scattered light lens (10). By doing this the light that is diffracted on the boundary of the light beam is not detected as scattered light. The image of the field lens (2) is projected through the intermediate image lens (3) and the collimator (5) on the aperture lens (6). Four measurements are made, as shown in Table 3 below.

Table 3 The Four Measuring Conditions According to the Annular Diaphragm Method for Measuring Scattered Light (adapted from German Standard DIN 52298-1)

Measured light flow	Windscreen in position	Lens used	Explanation
ϕ_{OL}	No	Aperture lens (12)	Incident light
ϕ_{OR}	No	Annular lens (8)	Scattered light of the testing equipment without windscreen
ϕ_{IL}	Yes	Aperture lens (12)	Directed light let through by the windscreen
ϕ_{IR}	Yes	Annular lens (8)	Scattered light let through by the windscreen plus the scattered light of the testing equipment with windscreen

Evaluation of the Windscreen Condition:

The reduced luminance coefficient q (degree of scattered light) is then calculated according to the following equation.

$$q = 1/\Omega (\phi_{IR}/\phi_{IL} - \phi_{OR}/\phi_{OL}) = 1/\Omega ((\phi_{IR} - \tau_r * \phi_{OR})/\phi_{IL})$$

where

$$\Omega = 1.67 * 10^{-3} \text{ sr (Spatial angle encompassing the annular lens)}$$

$$\tau_r = \phi_{IL}/\phi_{OL} \text{ (Directed transmission ratio of the test piece)}$$

The final test report for the windscreen must state the following:

- a) The selection of test pieces and preparation of the windscreens
- b) In the case of windscreens installed in vehicles, the age of the vehicle and mileage (odometer reading)

- c) Type of shield (eg. laminated safety glass, single shield safety glass)
- d) Dimensions and shape of the test piece (eg. Flat or curved shield)
- e) Type of shield (eg. Windscreen)
- f) Number of test pieces
- g) Tested areas of the shield and their orientation to the light beam
- h) Reduced luminance coefficient q in $\text{cdm}^{-2}\text{lx}^{-1}$ rounded off to the nearest $0.1\text{cdm}^{-2}\text{lx}^{-1}$
- i) Deviations from this standard.

4.4.2 Hand Held Devices for Measuring Stray Light

Schwahn Systems have been producing different types of stray light analysers since 1990. The first device was the CCD-Stray Light Analyser, which is a large but portable measuring fork designed for precise laboratory testing on glass objects. The device records stray light between the angles of 1.5 to 2 degrees to the forward undisturbed transmitted light. The degree of windscreen degradation is measured as the reduced luminance coefficient (or SLI). This unit costs DEM 34,500 (approximately AUD\$27,700).

Schwahn Systems have more recently developed a mobile reflex-stray light analyser called the StrayLizer. Similar to the CCD-Stray Light Analyser, the StrayLizer records stray light at the forward stray light angle of 1.5 to 2.5 degrees to the undisturbed transmitted light. The StrayLizer is a small handheld unit weighing 1.2 kg that is designed for measuring wear on installed windscreens. The degree of windscreen wear is measured using the SLI, and is displayed on a screen area of 20 by 10 mm. The StrayLizer costs DEM 9,850 per unit (approximately AUD\$7,900).

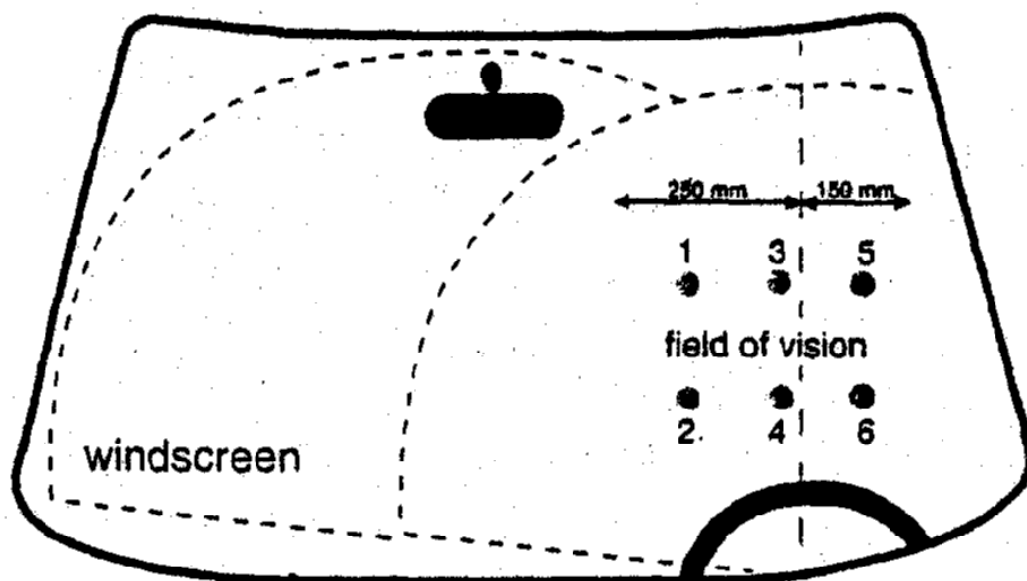

Fig. 9. Stray light measurement points in the field of vision.

Figure 21 The Six Points on the Windscreen in the Drivers Main Field of View Where Measurements with the StrayLizer are made (from Schwan Systems Product Information).

Measurements using the Straylizer are taken from six points on the windscreen across the drivers field of vision (Figure 21). The output is printed on a small portable printer in the

form of a spot diagram, an example of which is shown in Figure 22. The SLI for each of the six measurement points on the windscreen is plotted, and the mean SLI across the six data points is shown (Figure 22). For this device, an SLI of 1.5 has been adopted as the cut-off for distinguishing between acceptable and non-acceptable windscreen damage; values below 1.5 representing good visibility¹.

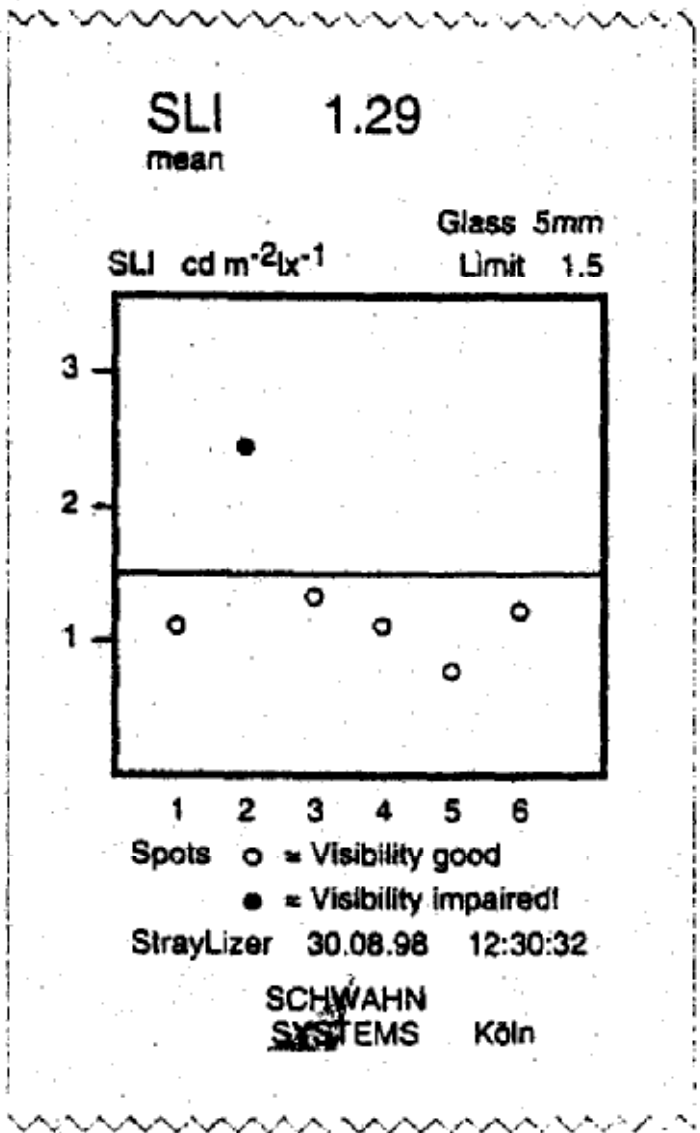

Fig. 10. Spot diagram.

Figure 22 An Example of a Spot Diagram Readout from the StrayLizer. SLI Values are on the Vertical Axis and the Six Measurement Points on the Windscreen are across the X Axis (from Schwann Systems Product Information).

¹ It is not clear on what basis an SLI of 1.5 was chosen. Further, while it is understood that the SLI is measured at six points on a windscreen, it is not clear whether it is a mean SLI of 1.5 that is used, or whether a reading of 1.5 at one or more of the six points is used. This issue is also relevant for the IRIS 504SC device (see next page), which also uses an SLI as an indicator of windscreen damage across ten points (rather than six).

DMO Optical Solutions also markets a mobile device to measure windscreen degradation. The IRIS 504SC is actually slightly smaller and lighter than the Schwan Systems StrayLizer, and as such is also designed to be used in the field by maintenance personnel (see Figure 23). It consists of a control unit (weight 440g), an optical head that is placed on the windscreen (weight 440g), and a calibration unit (450g) (IRIS 504SC User's Manual). Up to 400 measurements can be stored in the unit, and the data can be printed or downloaded onto computer.

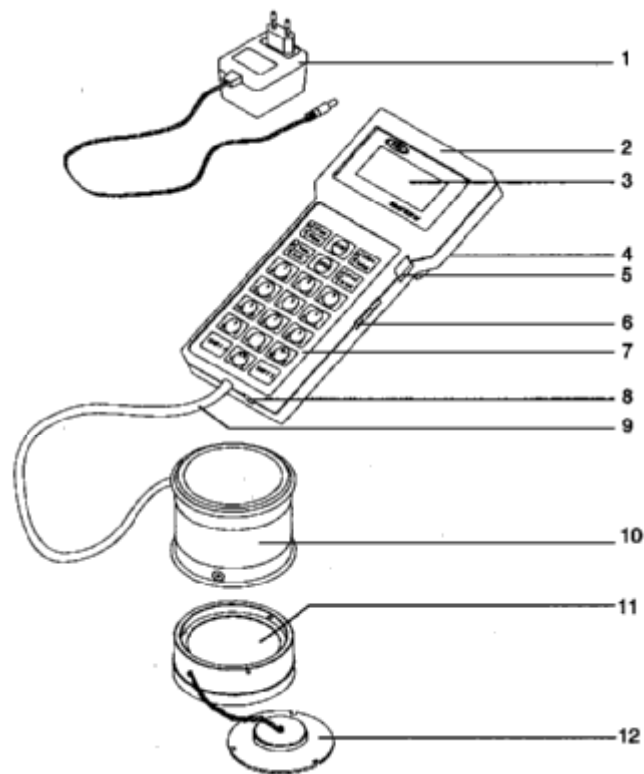

Figure 23 The components of the IRIS 504 SC device for measuring stray light in mounted windscreens

The components of the IRIS 504 SC, as illustrated in Figure 23, are as follows:

1. Charger
2. Control unit
3. LCD display
4. Batteries
5. RS-232 connection
6. Switch on/off
7. Keyboard
8. Charger connection
9. Shielded cable
10. Optical head
11. Calibration gauge

The IRIS unit can be used indoors or outdoors, and windscreen degradation is also measured using the SLI. Unlike the StrayLizer however, the IRIS 504SC measures scattering from a point 15 degrees from the specular (the undisturbed incident light beam), but we are unsure how this affects performance compared to the StrayLizer which measures scattered light between 1.5 and 2 degrees from the incident light beam.

The IRIS 504SC is set up to collect data in sets of ten measurements. It is possible to collect SLI values for each measurement point alone, but it is also possible to obtain a mean SLI value across these ten measurements. The number of measurements per data set can be changed. The time and temperature are also recorded. It is recommended that the unit is calibrated approximately monthly with the calibration unit that is provided.

Providing that it is properly validated, the IRIS 504SC unit appears very promising as a user-friendly and portable technique for measuring stray light in mounted windscreens. The cost of the unit is however unknown at this point. This unit has been approved for use in Germany and Sweden, and DMO Consulting is currently in negotiations to have the unit approved in the USA (personal communication, Jean-Hervé Lecat, Sales & Marketing Manager, DMO Consulting, 26th July 2000).

4.5 AVIATION MEASURES

Haze has been measured in aircraft transparencies by the Hazemeter described in the American Standard D 1003. There are however aspects of the Hazemeter that are not ideal for use in aviation. For example, the Hazemeter is suited for small flat samples, and requires that the light source and detector are situated on opposite sides of the sample. Armstrong Laboratories has developed a modified version of the Hazmeter for the United States Air Force (Bartell & Unger, 1993). The Haze-o-Meter II can be used without removing the windscreen from the aircraft, and determines both the severity of haze and the correct time to repair the windscreen as a result of haze. It can be calibrated such that readings taken in the field are almost identical to those readings from the laboratory with the windscreen removed. The Haze-o-Meter II was trialed at Eglin Air Force Base, Fort Loterdale, on an F-15 windscreen. Further improvements were scheduled so that the device would be easily usable by maintenance crews. Further information about this device was not available.

KEY POINTS

- Modern techniques for measuring stray light in automobile windscreens have focussed on using the SLI as a measure of windscreen degradation. There are two devices that have been reviewed here that are designed to measure windscreen degradation in the field, in mounted windscreens, by maintenance personnel. However, the current cost of the devices may be a major barrier to their widespread use in Australia.
- There is little doubt that further research needs to focus on trying to establish a relationship between SLI values, windscreen degradation, driver visibility, and driver performance. It would then be possible for local authorities to define impaired windscreen visibility, in terms of an SLI critical value, with a high degree of confidence.

5 WHERE TO FROM HERE?

This review has highlighted the need for further research aimed at increasing knowledge about the relationship between windscreen degradation and safety and determining objective methods for deciding whether a windscreen should be replaced on safety grounds. A suggested research program for addressing these issues is outlined below.

5.1 FUTURE RESEARCH

The aims of any continuing research in windscreen safety performance should be to address issues identified throughout this report that require additional substantiation and development. These are as follows.

1. First, to undertake research aimed at identifying the consequences of varying degrees of windscreen degradation on driver performance and crash outcomes.
2. Second, to develop and evaluate a low-cost instrument capable of measuring degrees of windscreen degradation resulting from sandblasting and general wear and tear.
3. Third, to develop recommendations for a windscreen standard and guideline that clearly identifies objective criteria for determining degradation that renders a windscreen unsafe.

These outstanding research items are elaborated upon in more detail below.

5.1.1 The Link Between Windscreen Degradation and Safety

The literature review failed to yield any meaningful information regarding the size of the safety problem resulting from windscreen degradation. It is well documented that vision is the predominant source of information that drivers rely on for safe driving, and that degraded windscreens may interfere with a driver's vision of the road ahead. The literature reviewed however, did not clearly identify objective levels of degradation that render a windscreen unsafe. Conceivably a windscreen containing chips, scratches and "sandblasting" impurities would be undesirable, but to what extent safety is compromised (by the degree of degradation) is unclear from the literature reviewed. Two approaches are suggested to address this shortcoming.

Crash Study. A study should be conducted to assess the extent of the problem and the potential role of windscreen degradation factor in vehicle crashes. One way that this could be done, for example, would be to examine the state of windscreens in vehicle that crash and comparing these findings with those from a similar sample of non-crashed vehicles. Such a study would help quantify the benefits of any further legislation prescribing acceptable windscreen conditions.

Performance Study. There is clearly a benefit in having a clean faultless windscreen to maximize a driver's safety. However, it is difficult to assess precisely the relationship between windscreen degradation and crash involvement, given the many confounding factors associated with road crashes. As a precursor, an experimental program using a realistic driving simulator could be conducted to demonstrate the consequences of windscreen degradation on driving performance. The research should be conducted with reference to the study (mentioned earlier in the report) currently being conducted by ICE in the United Kingdom.

5.1.2 Measurement Device

Any further research in this area would necessarily require an appropriate measuring instrument to assess the degree of windscreen degradation objectively. The review highlighted two devices that could be useful for this purpose, but evidence to date suggests that these devices are prohibitively expensive for widespread use and may also be limited in scope.

It was acknowledged that an instrument developer, with experience and commercial benefit in developing such a device, would best undertake any future development of a more appropriate and low cost device. However, researchers with knowledge of the role of windscreen degradation and safety would be well placed to contribute to the development of specifications for such a measurement device in conjunction with an instrument maker, and to evaluate its effectiveness.

The proposed research in this component of the program would include a task of outlining the critical specifications necessary for such a device based on the findings from other components of the program.

5.1.3 Development of a Suitable Standard

The review of windscreen standards around the world showed a general inconsistency and inadequacy in the assessment of windscreen degradation. The German standard appears to be the only standard in the world currently that deals quantitatively with the measurement of scattered light that can result from windscreen degradation.

It would be important for any future research in this area to include a component devoted to developing a suitable standard that objectively defines the level of degradation that renders a windscreen unsafe. It would be hoped that this standard could be applied in Australia and perhaps overseas to improve the visibility of windscreens generally. It would be expected that this would lead to improved vision through the windscreen for drivers and would ultimately lead to safety benefits for all road users.

5.2 CONCLUSION

The review carried out as part of this research program has highlighted many important aspects of windscreen safety and its assessment around the world. However, there are still many unanswered questions regarding the relationship between windscreen degradation and safety performance that could not be answered. Further research is warranted to address these outstanding items. In particular, the need to understand the nature of driver performance difficulties from not having a clear and faultless windscreen and the likely extent of the problem of windscreen degradation as a cause of road crashes.

This additional research will then help to identify objective criteria for assessing windscreen degradation and the need for further regulation and assessment regarding road user safety from degraded windscreen vision that could not be answered during this review.

REFERENCES

- Allen, M. (1969). Automobile windshields - Surface deterioration. *American Journal of Optometry and Archives of American Academy of Optometry*, 46(8), 594-598.
- Allen, M. (1970). *Vision and Highway Safety* (First ed.). Philadelphia: Chilton Book Company.
- Allen, M. (1974). Windscreen dirt and surface damage effects. *Australian Road Research*, 6, 7-19.
- Allen, M., Abrams, B., Ginsburg, A., & Weintraub, L. (1996). *Forensic Aspects of Vision and Highway Safety*. Tucson, Arizona: Lawyers & Judges Publishing Company, Inc.
- Bartell, R., & Unger, S. (1993). *Backscatter haze device for measurement of haze in aircraft transparencies* (Final report AL/CF-TR-1993-0102). Dayton, Ohio: Logicon Technical Services, Inc.
- Chauhan, K., & Charman, N. (1998). *The mandelbaum effect and night driving*. Paper presented at the Vision in Vehicles - VI, Derby, UK.
- Chmielarz, M., Groetzner, C., & Haase, O. (1987). *Vision-impairing wear of windshields*. Paper presented at the 11th International Technical Conference on Experimental Safety Vehicles, Washington DC.
- Derkum, H. (1991a). Effects of stray light on perception. *Sprechsaal*, 124(10), 679-685.
- Derkum, H. (1991b). *Stray light in windshields - Measurement and effect*. Paper presented at the Vision in Vehicles - III.
- Green, P., & Burgess, W. (1981). *Windshield damage and driving safety* (Technical Report UM-HSRI-81-35). Ann Arbor: The University of Michigan, Highway Safety Research Institute.
- Haase, O., Schneider, W., Helmers, G., & Timmermann, A. (1989). *Vision impairment by worn windshields during night-time driving* (890686): Society of Automotive Engineers.
- Hartley, L., Lamble, D., & Penna, F. (1995). *Effects of reduced visibility caused by visually degraded windscreens on driver fatigue* (Prepared for Windscreens O'Brien): Institute for Research into Safety & Transport, Murdoch University.
- Helmers, G., & Lundkvist, S. (1989). Detection distances to obstacles on the road seen through windscreens in different states of wear. *Nordic Road and Transport Research*, 1(1), 21-22.
- Henderson, R., Smith, R., Burger, W., & Stern, S. (1983). *Visibility From Motor Vehicles* (SAE Technical Paper Series 830564). Detroit, Michigan: SAE.
- Holgate, J., Harkness, D., Vertsonis, H. (1999). New South Wales crashed vehicle study. *Presented at the Road Safety Research, Policing and Education Conference, 28-30 November, Canberra*.
- Holtmann, K., Frischat, G., & Ruppert, K. (1994). *Mechanism of defect creation on sheet glass by particle impact and its influence on stray light*. Paper presented at the 68th Annual Meeting of the German Society of Glass Technology (DGG), Bad Salzdetfurth, Germany.

- Jabbour, L. (1999). Windscreen standard hits the bullseye. *The Australian Standard*, 20(5), 33.
- Kessler, F. (1991). *Light diffusion characteristic and visibility interferences in automobile windscreens*. Paper presented at the Vision in Vehicles - IV, University of Leiden, The Netherlands, 27-29 August 1991.
- Lundkvist, S., & Helmers, G. (1993). *Visibility distance to obstacles for drivers with a worn windscreen and / or impaired visual acuity* (VTI Rapport 382). Linköping: Swedish Road and Traffic Research Institute.
- Malaise, D. (1998). *Technical Measurements on Cars Windows to Ensure Visibility and Security*, Unpublished manuscript.
- Olson, P. (1996). *Forensic Aspects of Driver Perception and Response*. Tucson, Arizona: Lawyers & Judges Publishing Company, Inc.
- Owens, D., Sivak, M., Helmers, G., Sato, T., Battle, D., & Traube, E. (1992). *Effects of Light Transmittance and Scatter by Windshields on Nighttime Visual Performance* (UMTRI-92-37). Ann Arbor, Michigan: The University of Michigan, Transportation Research Institute.
- Rompe, K., & Engel, G. (1984). *The Influence of Scattered Light in Windshields on Driver's Vision During Night Driving* (SAE Technical Paper Series 840385). Cologne: SAE.
- Sayer, J., & Traube, E. (1994). *Factors influencing visibility through motor vehicle windshields and windows: A review of the literature* (UMTRI-94-20). Michigan: The University of Michigan, Transportation Research Institute.
- Schumann, J., Flannagan, M., Sivak, M., & Traube, E. (1997). Daytime veiling glare and driver visual performance: Influence of windshield rake angle and dashboard reflectance. *Journal of Safety Research*, 28(3), 133-146.
- Timmermann, A. (1985a). *Direct measurement of windscreen surface wear and the consequences for road safety*. Paper presented at the Vision in Vehicles, Nottingham, United Kingdom, 9-13 September 1985.
- Timmermann, A. (1985b). *An instrument to measure scattered light due to windshield wear*. Paper presented at the Proceedings of the 10th International Technical Conference on Experimental Safety Vehicles.